

Return-Yoke Free Magnet for 150MeV FFAG

Yoshimasa YUASA

””””

In KEK-FFAG group

Schedule



- Done/Do by magnet team
 - FFAG consists of 12 magnets

	2001												2002											
	1	2	3	4	5	6	7	8	9	10	11	12	1	2	3	4	5	6	7	8	9	10	11	12
Construction Phase #1	12 Yokes and 6 pair of coil						Measurements of 6 magnets																	
Construction Phase #2							6 pair of coil						Preparing equipment						Remaining Measurements					
Setup																			Alignment					

- 6 magnets were constructed
- Their magnetic field measurements were finished
- Others are constructing and their measurement are preparing

Contents

- Return-Yoke Free Magnet
- Magnet for 150MeV FFAG
- Magnetic Field Measurement
- Summary

Return-Yoke Free Magnet

- Our developing magnet structure
 - Removing a return yoke of central pole

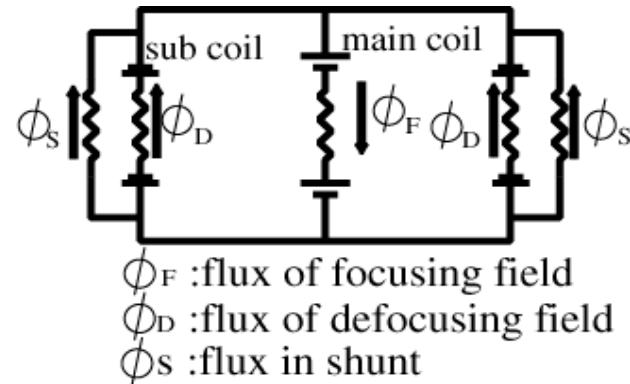
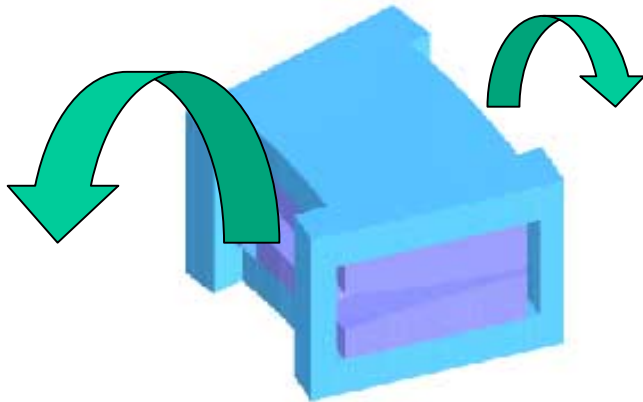

➡ “Return-Yoke Free”

- Main magnetic flux generated by a central coil provide not only a focusing field in a central pole itself but also a defocusing field in side poles

Magnet for 150MeV FFAG

- Design and picture

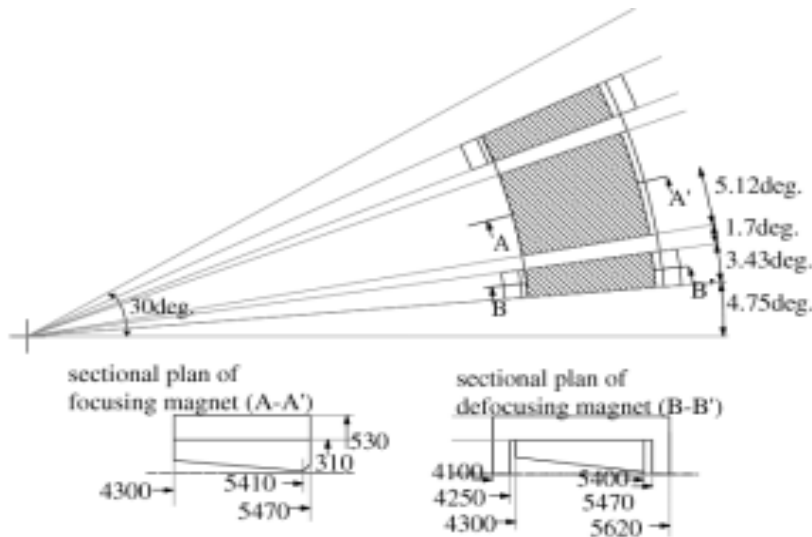

$$\text{halfgap}(F_1) = -0.156 \times (r - 4475) + 90.079$$

(4300 < r < 4475)

$$\text{halfgap}(F_2) = 21 \left(\frac{5400}{r} \right)^{7.75}$$

(4475 < r < 5410)

$$\text{halfgap}(D_1) = -0.156 \times (r - 4475) + 90.079$$

(4300 < r < 4500)

$$\text{halfgap}(D_2) = 20 \left(\frac{5400}{r} \right)^{9.32}$$

(4500 < r < 4900)

$$\text{halfgap}(D_3) = 39.9 \left(\frac{4900}{r} \right)^{11.555} + 9.57$$

(4900 < r < 5400)

k-value = 7.6



Magnetic Field Measurement

- In order to check a consistency with our design and a feasibility for 150MeV FFAG
- Recent measurement has been done
 - 1D magnetic field on median plane
 - Magnetic fields vs. F/D coil currents
 - Comparison between data and calculation
 - Consistency between one and others
- Next measurements is in preparing
 - 3D magnetic field in a gap
 - Detail information of magnetic field
 - Higher resolution than traditional and previous one

Recent Measurement

- Condition

	F coil	D coil
125MeV	910A	780A
150MeV	1168A	560A

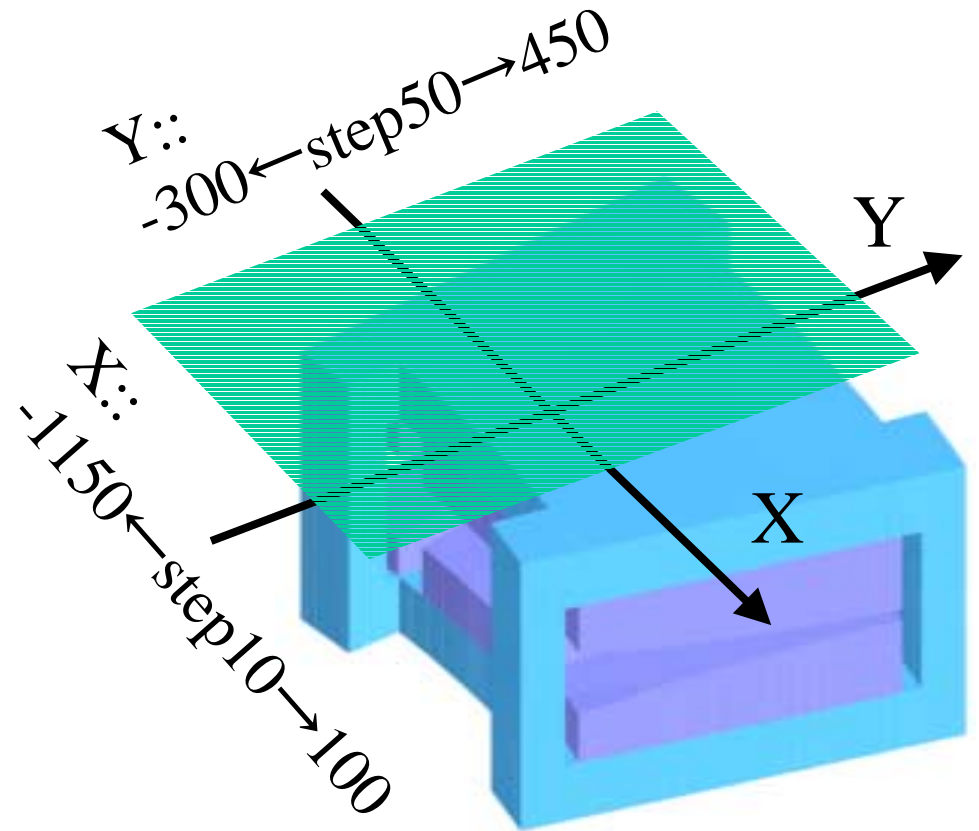

Recent Measurement

- Setup

	Item
Magnet Field	Hole Probe + Teslameter DTM-141 (Group3)
Position	2D Movable Stand (Kozu Inc.)
Temperature	Thermocouple + Digital Multimeter TR2114 (ADVANTEST)
Current	Constant Current Supply (Hitachi LTD) + Digital Multimeter

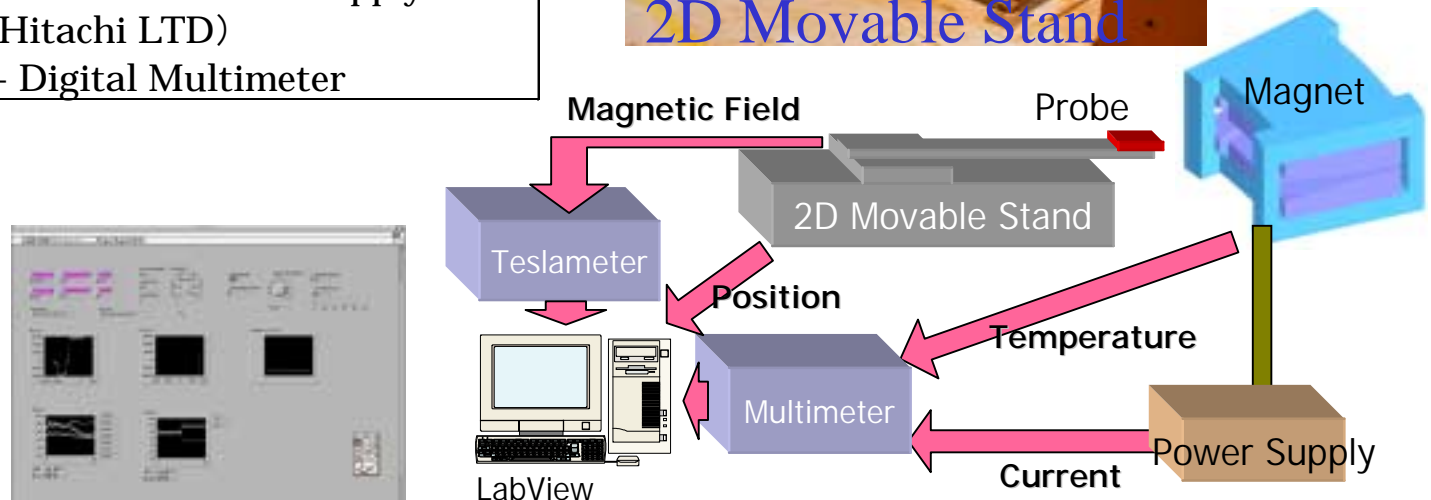

Recent Measurement

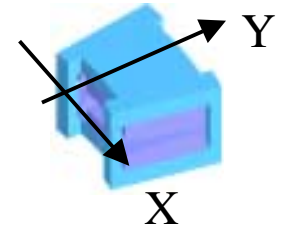

- Results

Magnetic Field on No1 @ 125MeV

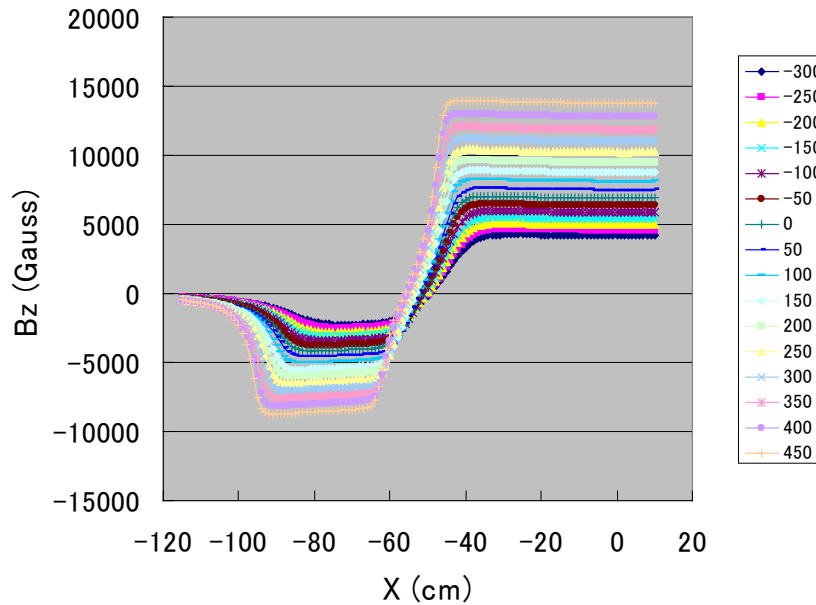

Magnetic Field on No1 @ 150MeV

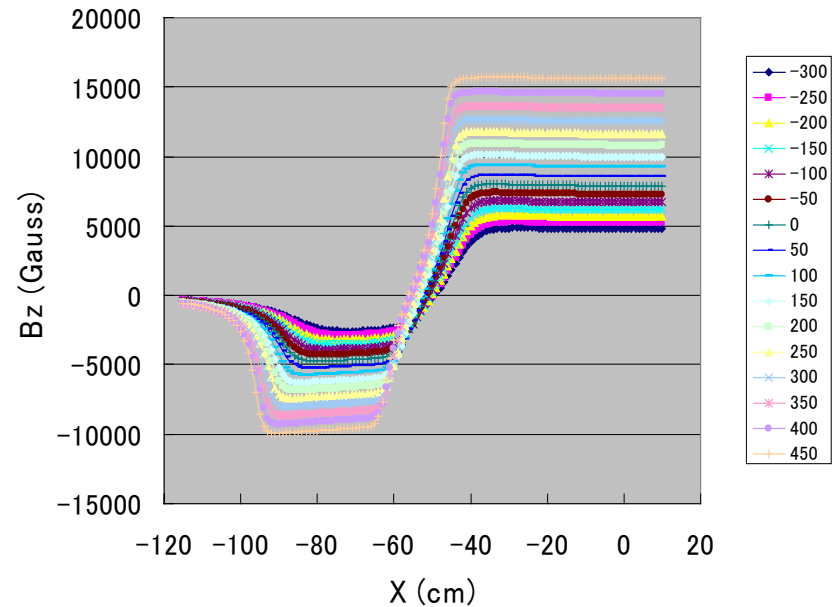

- 1D magnetic fields of 6 magnets are measured on 2 setups of coil current

Recent Measurement

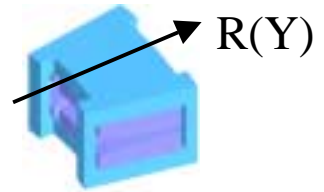

- comparison of R-dependence on X=0

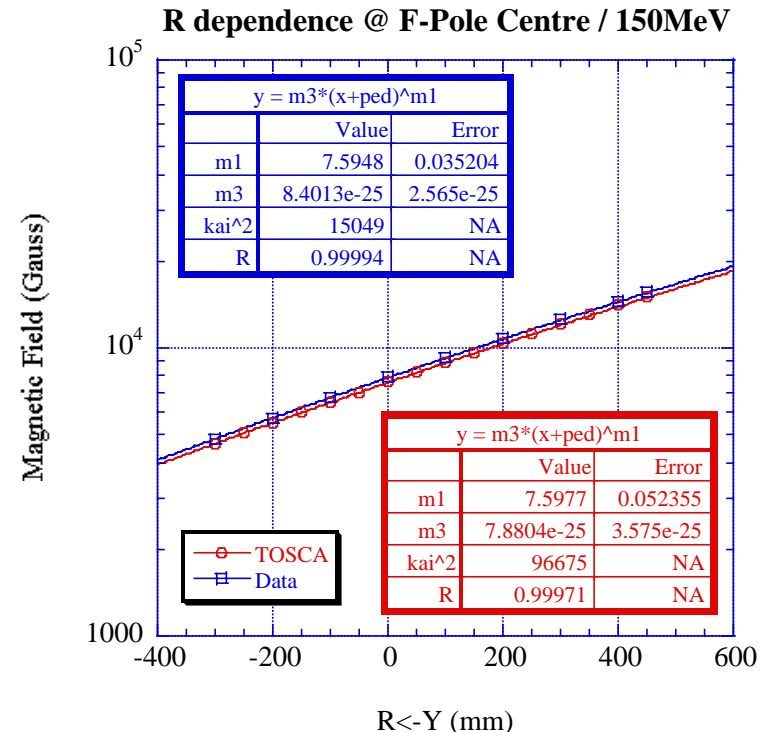
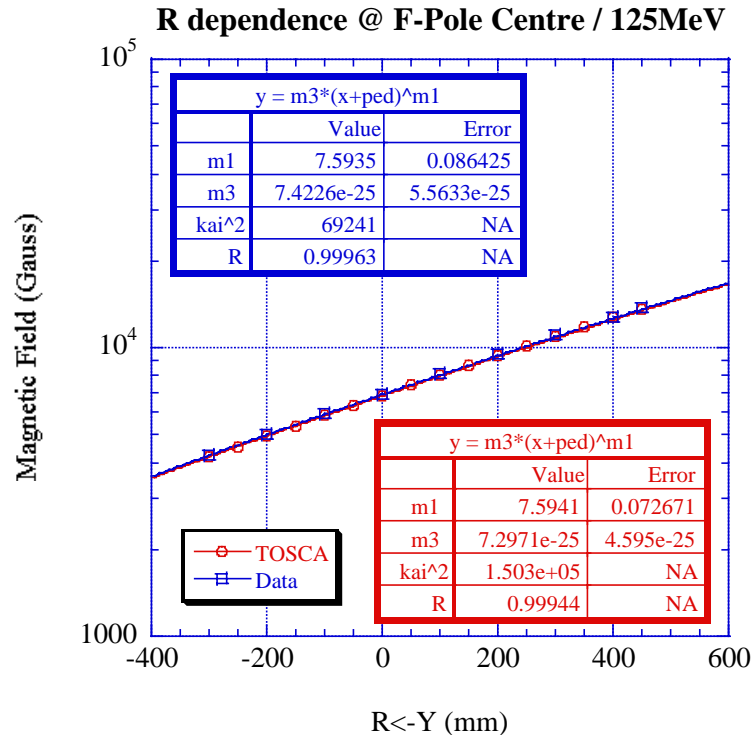

– K-value=7.6 is consistent between data and calculation

Recent Measurement

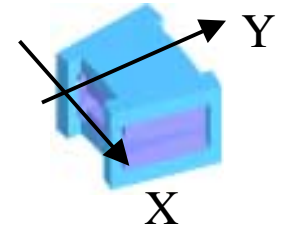

- comparison on median plane

Comparison @ 125MeV

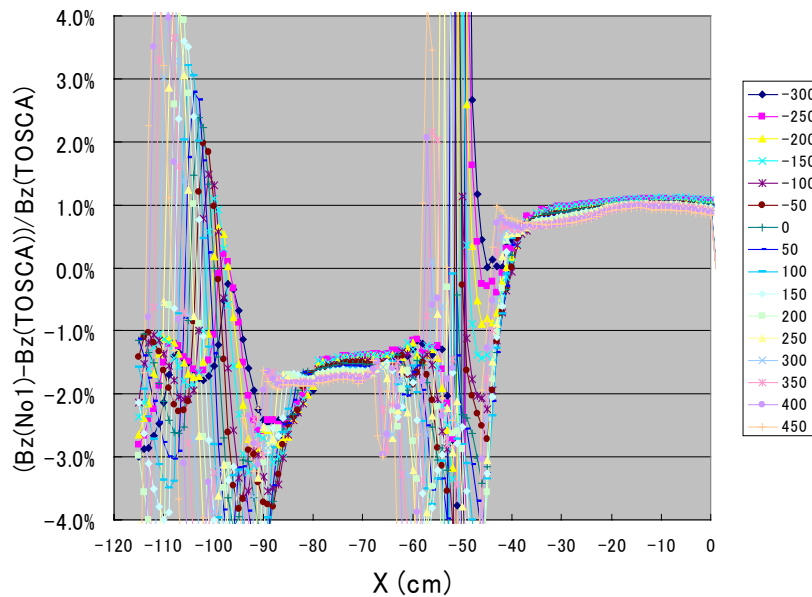

Comparison @ 150MeV

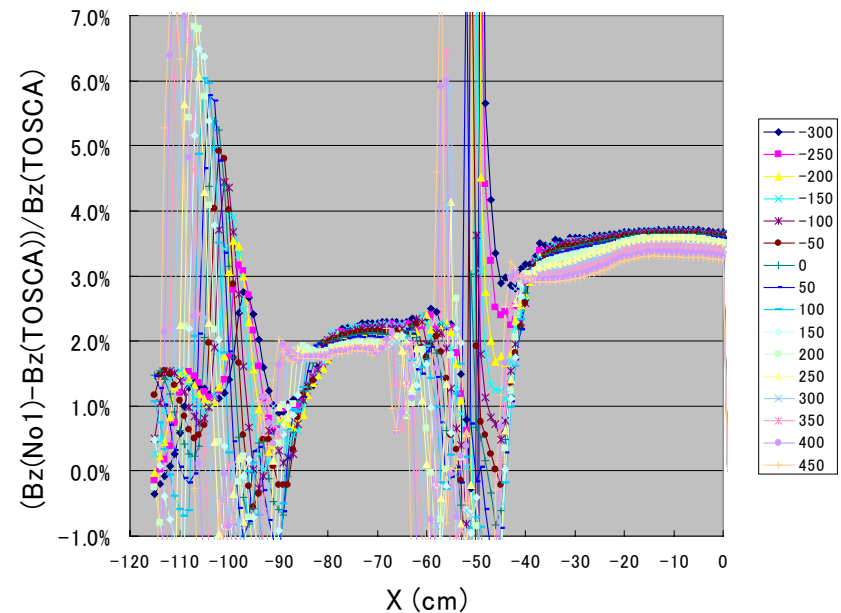

- A few % is different between data and calculation
- F+D coil currents are able to tune magnetic fields

Recent Measurement

- Magnetic fields vs. F+D coil currents

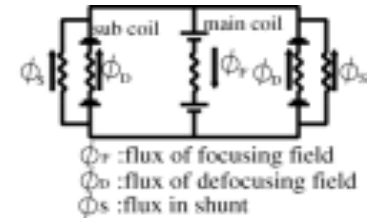

Magnetic Field @ D-Pole

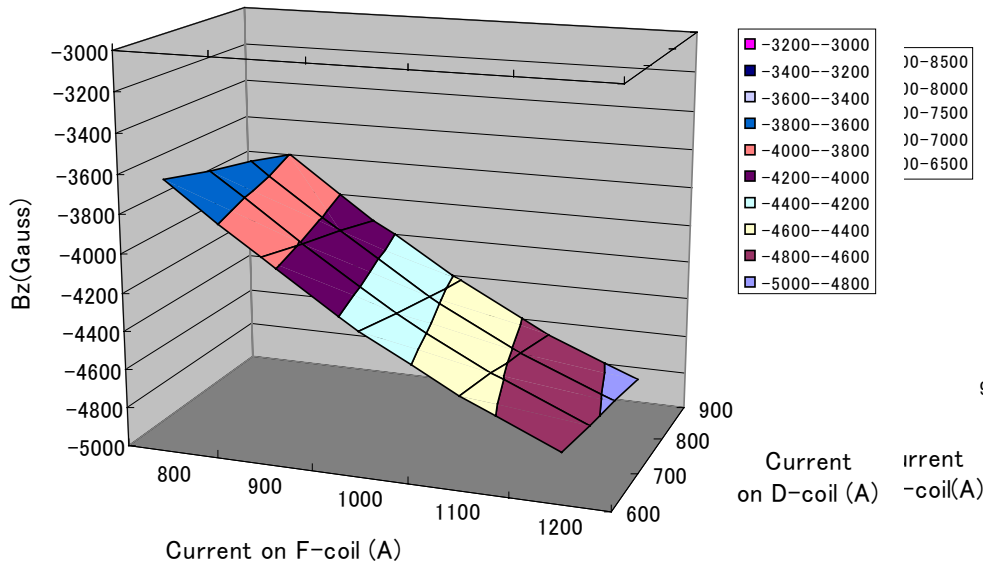

Magnetic Field @ F-Pole

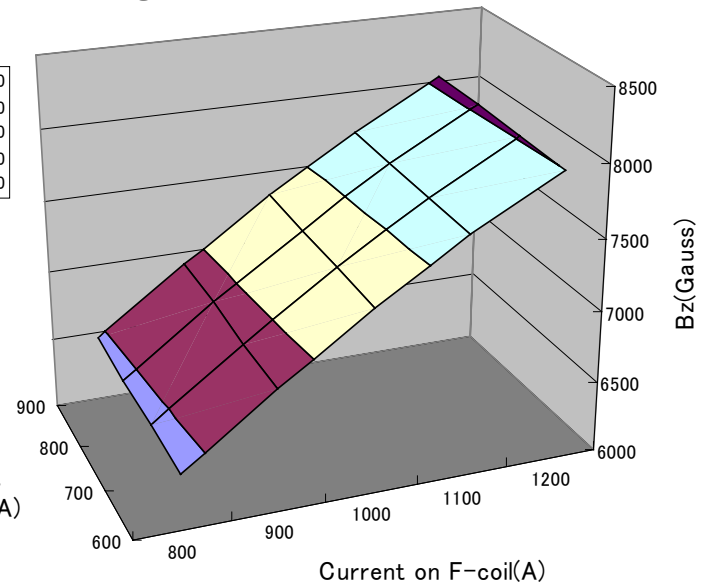

- The correlation is appeared due to the characteristic magnetic circuit of “Return-Yoke Free Magnet”

Recent Measurement

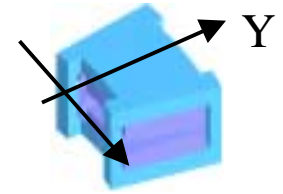

- Consistency between one and others

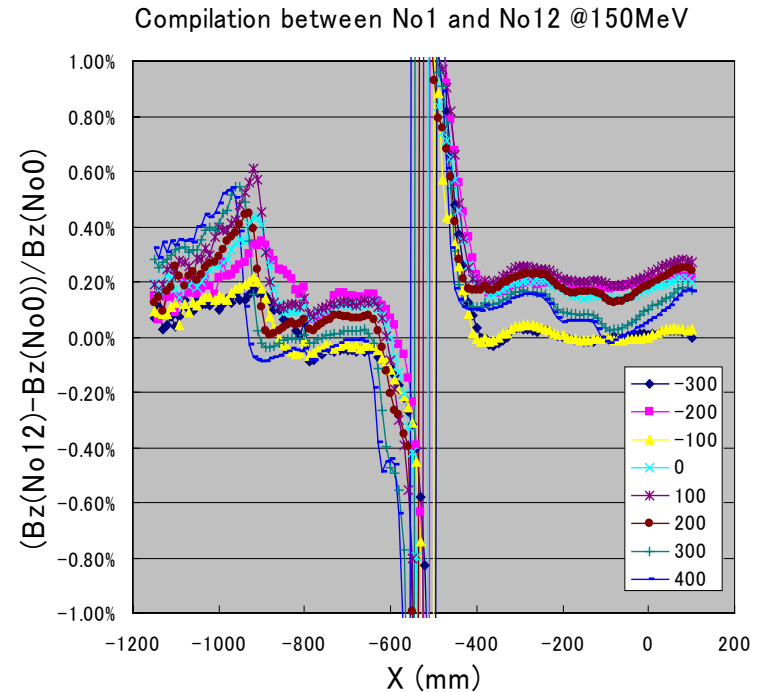
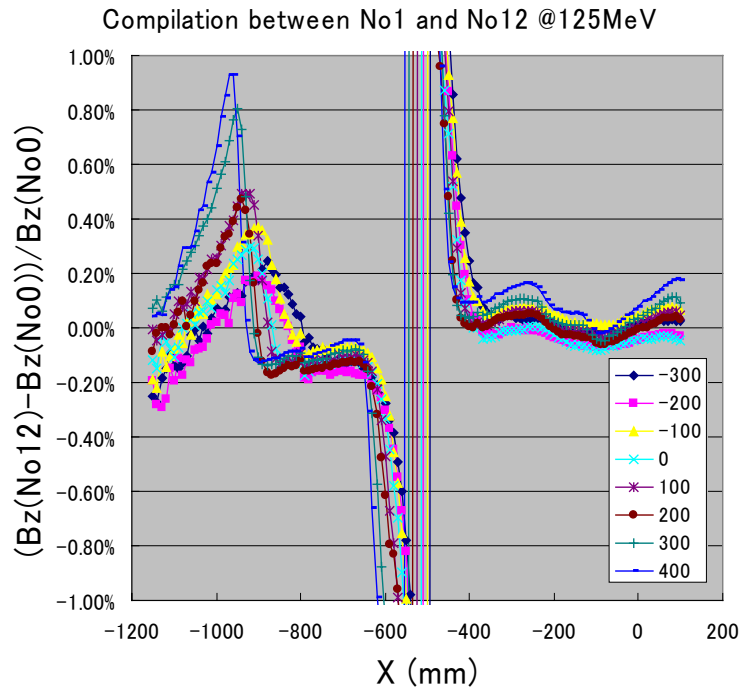

- Relative discrepancy $\sim 0.3\%$ is consistent with a resolution of probe position $\sim 1\text{mm}$

Next Measurement

- Motivation
 - 3D magnetic field in a gap
 - With higher resolution

	Recent		Next		Traditional	
Alignment	0.03% (0.2mm)		0.03% (0.2mm)			
Position	0.15% (1.0mm)	Kozu Inc	–% (0.01mm)	NSK Inc		
Tilt angle			1.40% ($\pm 0.8\text{deg}$)	3*1D probe	3.49% ($\pm 2\text{deg}$)	3D probe
Magnetic Field			0.03%	3*1D probe	0.65%	3D probe
	Total Accuracy		1.5%			
			↓ Calibrating probe tilt			
			0.1%			

- New equipment
 - 3*1D probe holder
 - Settle a exact place and angle
 - Tunable rotating angle for calibration

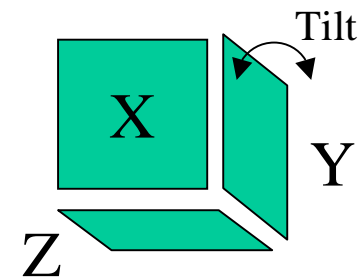

Next Measurement

- 3D probe holder

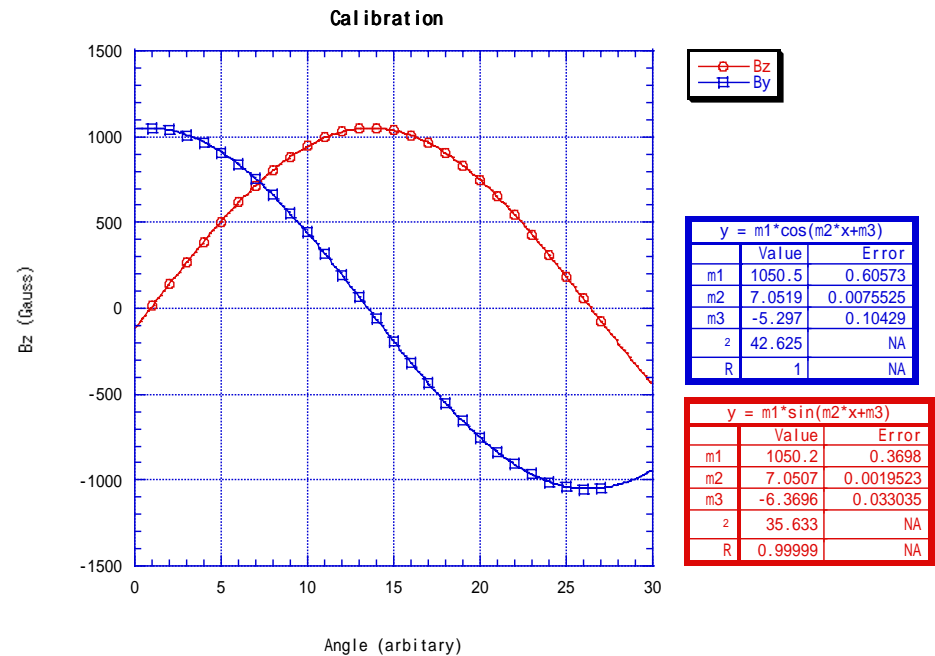

- The angle of tilt is consistent with a catalog specification
- With calibrating a tilt angle, the resolution gets higher

Summary

- 6 magnets of 12 were constructed. The remaining half will have constructed by this spring
- 1D Magnetic field measurements of 6 magnets were performed. These results are consistent with the measurement resolution and probe a feasibility for 150MeV FFAG
- Next measurement of 3D magnetic field with a higher resolution is ready to perform
- Magnet setup for ring is now considering