

R&D Status of PRISM-FFAG

Akira Sato
Osaka University

for the PRISM working group

FFAG04 @ KEK Oct 13, 2004

contents

- PRISM Overview
- Optics design
 - with unique method
- Magnet design
- RF R&D
- Summary & Issues

PRISM

Phase Rotated Intense Slow Muon source

Search for Lepton Flavor violation

$$B(\mu\text{-}N \rightarrow e\text{-}N) < 10^{-18}$$

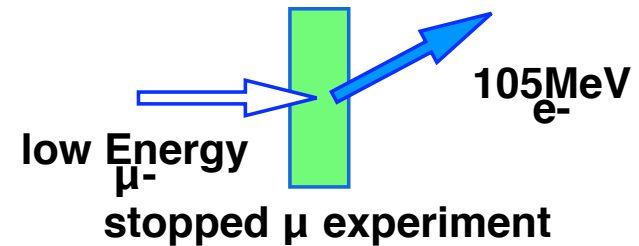

High Intensity

intensity : 10^{11} - $10^{12} \mu^\pm/\text{sec}$

beam repetition : 100-1000Hz

muon kinetic energy : 20 MeV (=68 MeV/c)

high power p beam,
super cond. solenoid pi capture
large acceptance FFAG

Narrow energy spread

kinetic energy spread : ± 0.5 -1.0 MeV

phase rotation

Less beam contamination

π contamination $< 10^{-18}$

long flight length in the FFAG

PRISM Layout

- *Solenoid Pion Capture
- *Pion-decay and Transport
- *Phase Rotation

FFAG advantages:

synchrotron oscillation

necessary to do phase rotation

large momentum acceptance

necessary to accept large momentum distribution at the beginning to do phase rotation

large transverse acceptance

muon beam is broad in space

PRISM-FFAG ring
construction has
started in JFY2003.

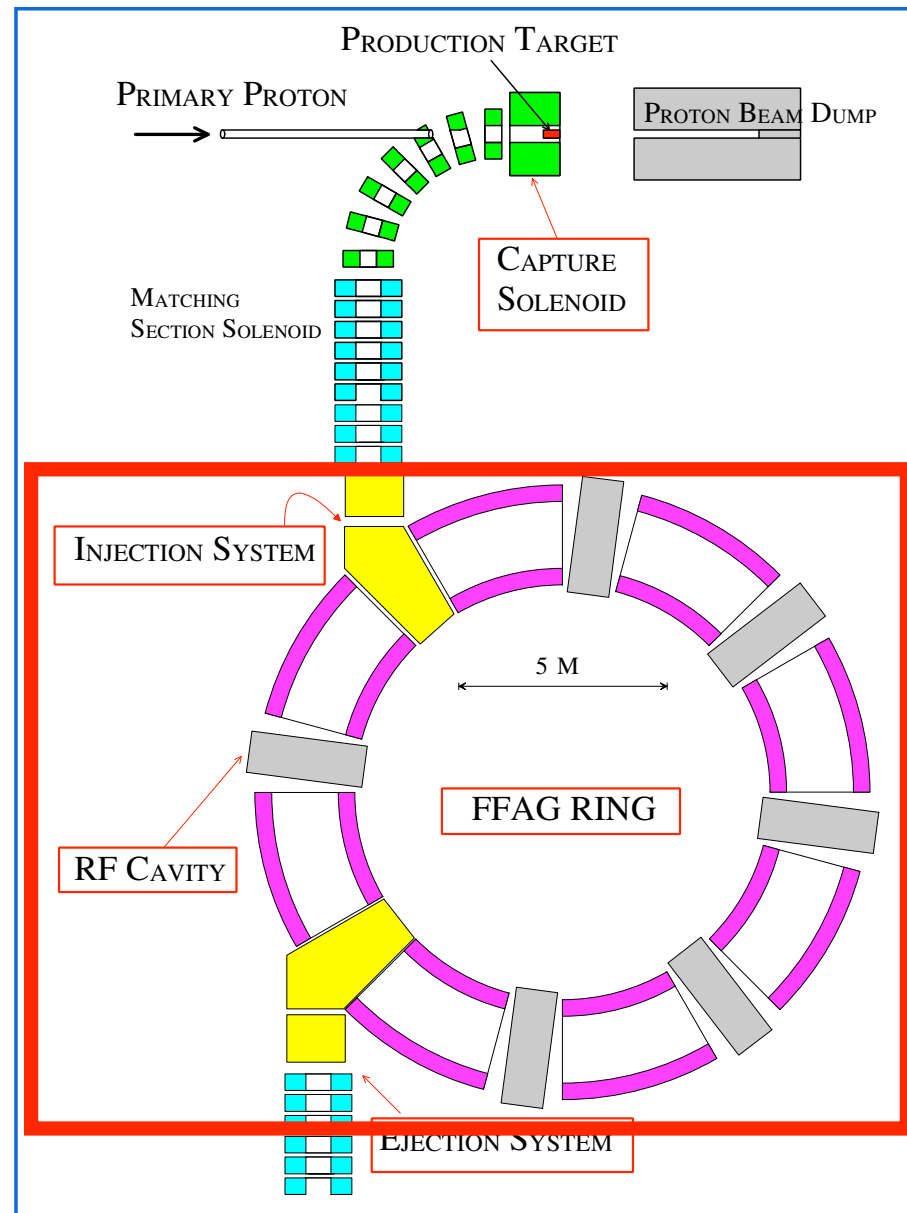

Schedule

- JFY2003: RF amp. production
- JFY2004: RF cavity construction, FFAG magnet construction
- JFY2005: FFAG magnet production (continue)
- JFY2006: FFAG magnet construction (completed)
- JFY2007: muon acceleration and phase rotation, test cooling?

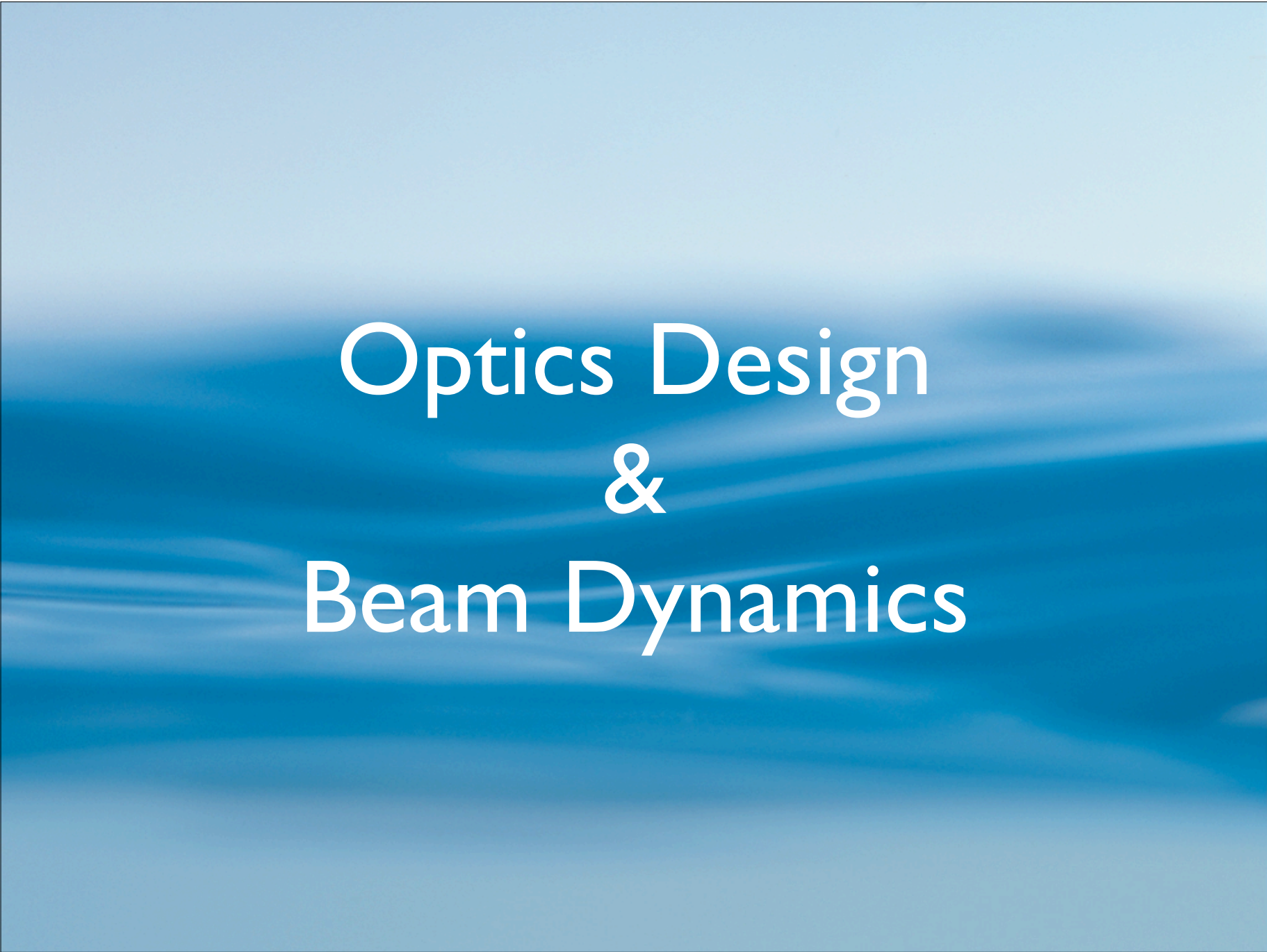

Optics Design
&
Beam Dynamics

PRISM-FFAG requirements

- Large acceptance
 - $H : >20000 \pi \text{ mm mrad}$
 - $V : >3000 \pi \text{ mm mrad}$
- Quick phase rotation ($\sim 1 \mu\text{s}$) & mom. acceptance (68MeV/c \pm 20%)
 - Compact magnet
 - RF field gradient $\sim 200\text{kV/m}$
 - $\sim 2\text{MV/turn}$
- scaling FFAG
- F/D : variable
- k value : variable

Tune study - PoP FFAG -

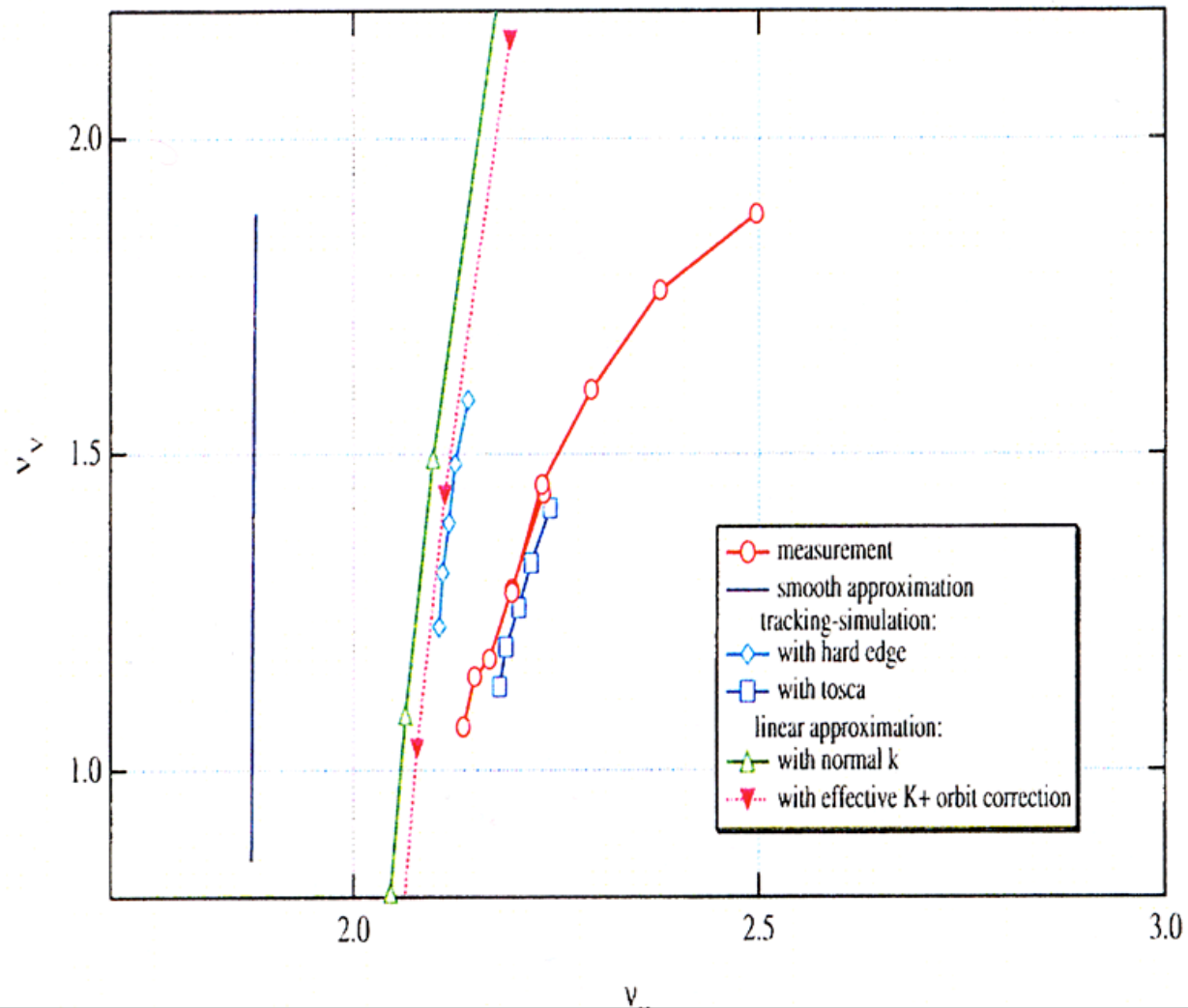

what's problem

- modeling of the fringing fields
 - TOSCA : perfect, but takes **long time**...
 - SAD, MAD ... : need **parameters (FINT)**
 - need real data or TOSCA
- field at position far from mid. plane
 - can estimated from field data of mid. plane
 - -> **doesn't work at high z.**

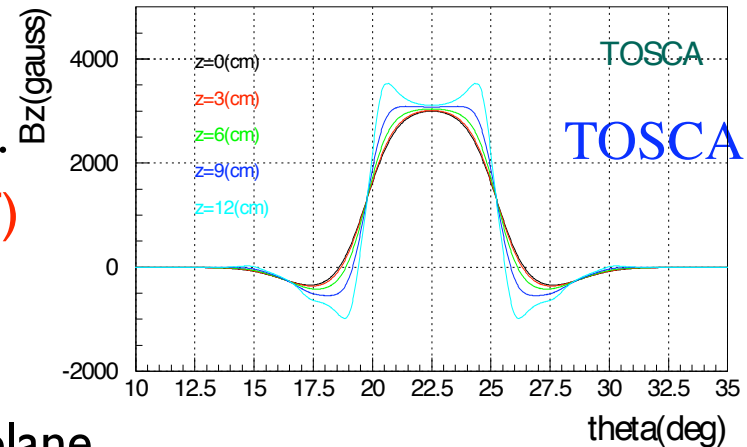

to study large aperture FFAGs

*model fringing field correctly

*calculate field at not only mid. plane but also off mid. plane

solution using POISSON

-> quasi-realistic 3D magnetic fields

How to make quasi-realistic 3D magnetic fields

step 1 :

calculate magnetic field $(B_\theta, B_z)(z, \theta)$ of each z - θ cross sections ($r1$ - $r5$). x -axis is considered as θ -axis (approximation).

step 2 :

convert the field $(B_\theta, B_z)(r_i, z, \theta)$ to $(B_z, B_\theta, B_r)(r_i, z, \theta)$ by using Maxwell eq.

$$B_z(z_i) = B_y(z_i)$$

$$B_\theta(z_i) = B_x(z_i)$$

$$B_r(z_i) = \left(\frac{dB_z}{dr} \right)_{(z_i)} (Z_i - Z_{i-1}) + B_r(Z_{i-1})$$

step 3 :

to make a fine mesh field map, apply a 2D spline interpolation to the above field map.

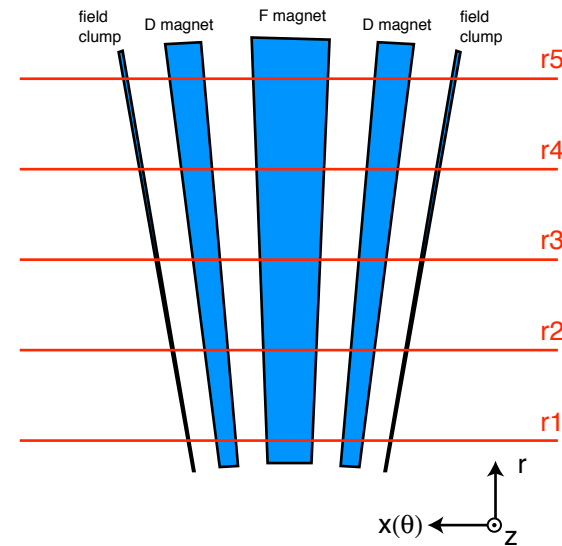

Figure 1: Top view of a triplet magnet.

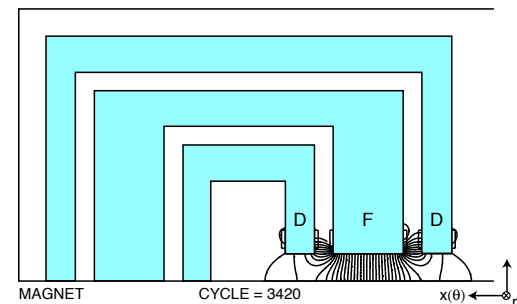
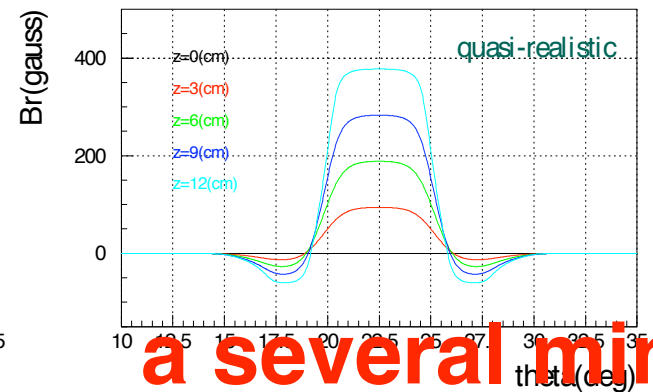
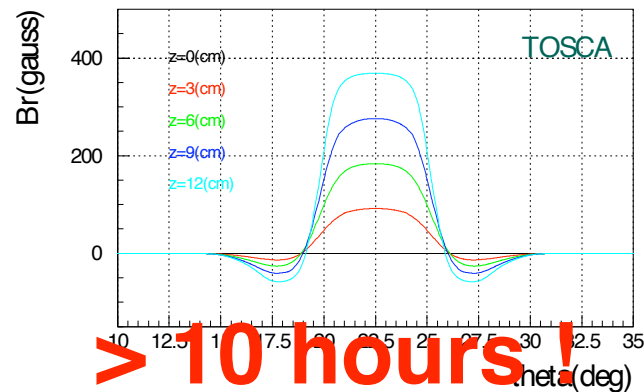
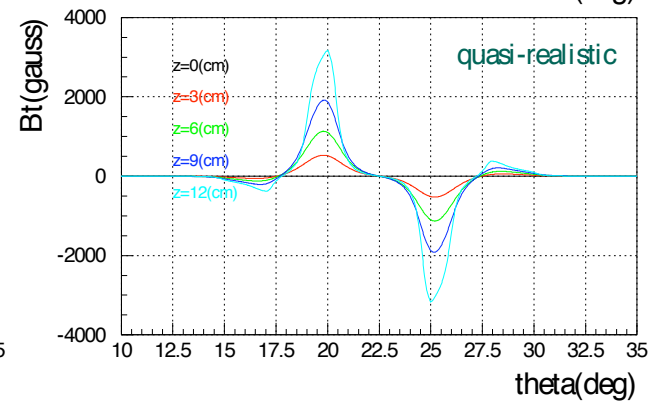
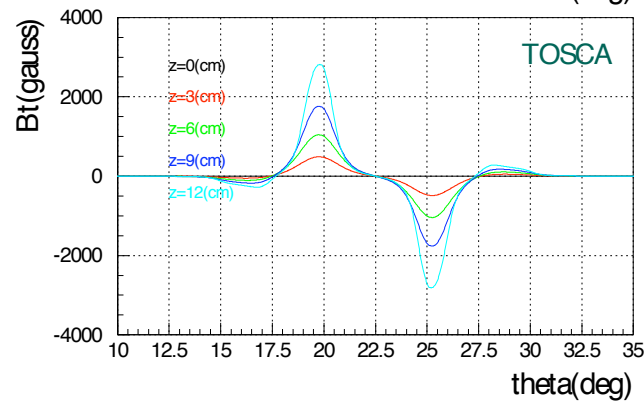
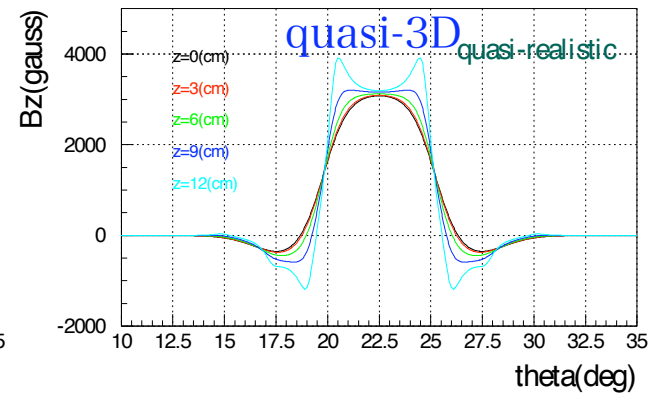
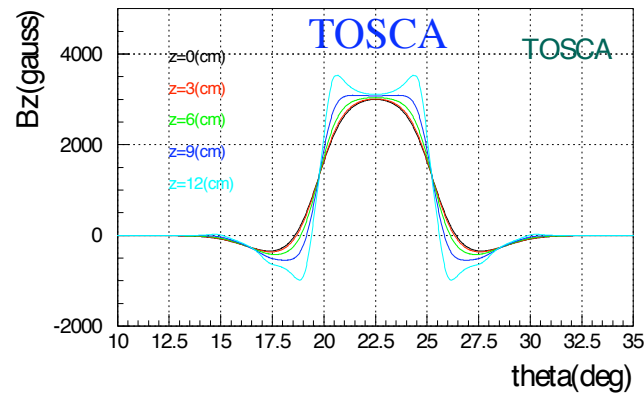

Figure 2: A magnet model used in POISSON calculation.

Comparison b/w TOSCA and quasi-3D



> 10 hours!

a several min.

Optics Design

quasi-3D mag. field

parameters :

number of cell

FD,DFD,FDF

k value

F/D ratio

gap size



3D tracking by geant3.21

to study :

acceptance (H,V)

tune

tune shift

beam size etc

2D Acceptance Study

DFD, $N=10$, half gap=15cm, w/o field clamps, $r_0=6.5\text{m}$ for 68MeV/c

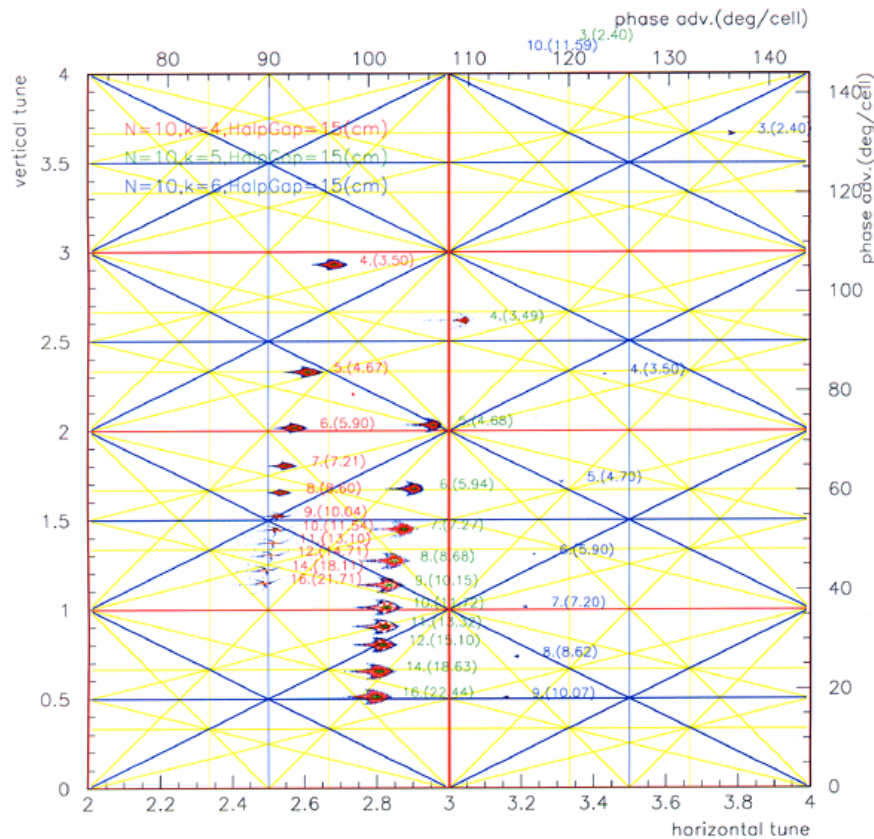

Horizontal phase spaces are plotted in a tune diagram.

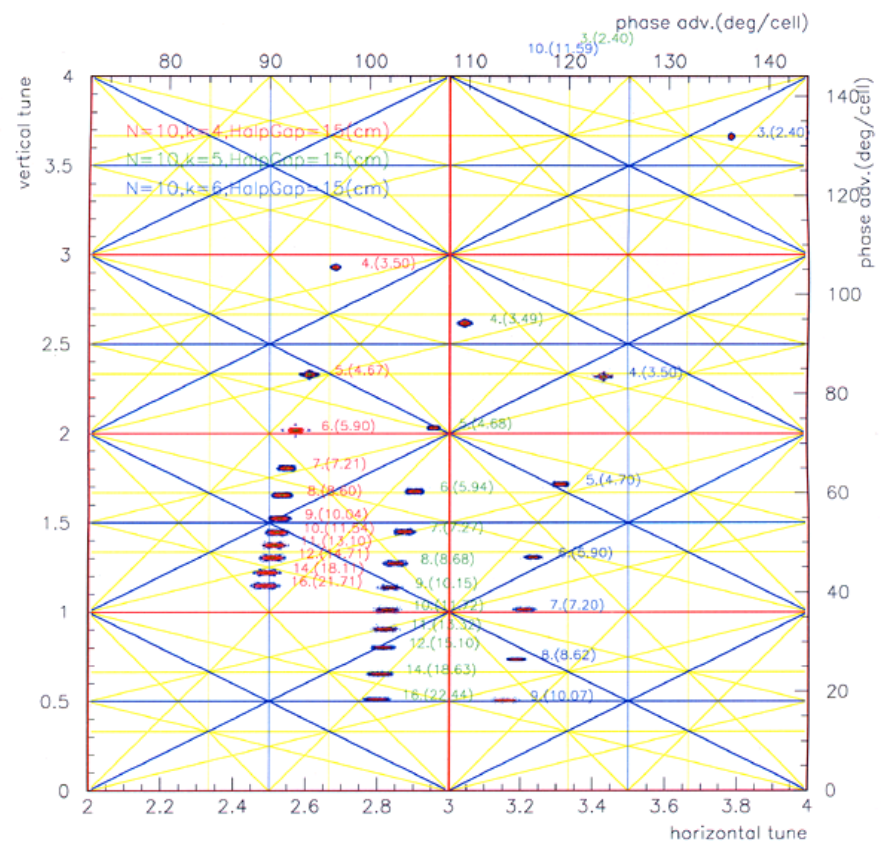

Vertical phase spaces are plotted in a tune diagram.

2D -> 4D acceptance

what is the 4D acceptance?

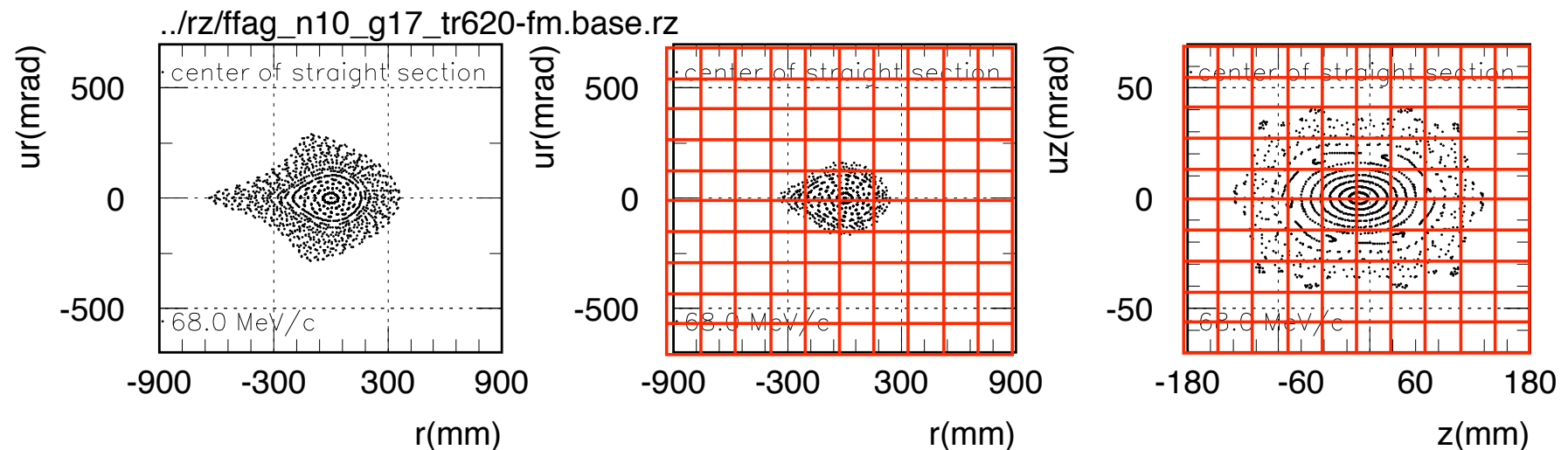

Horizontal

w/ zero v amp

Horizontal

w/ small v amp

Vertical

w/ zero h amp

acceptable condition : turn more than 6

Acceptance dependence on gap size of magnets

DFD, N=10, w/o field clamps, r0=6.5m for 68MeV/c

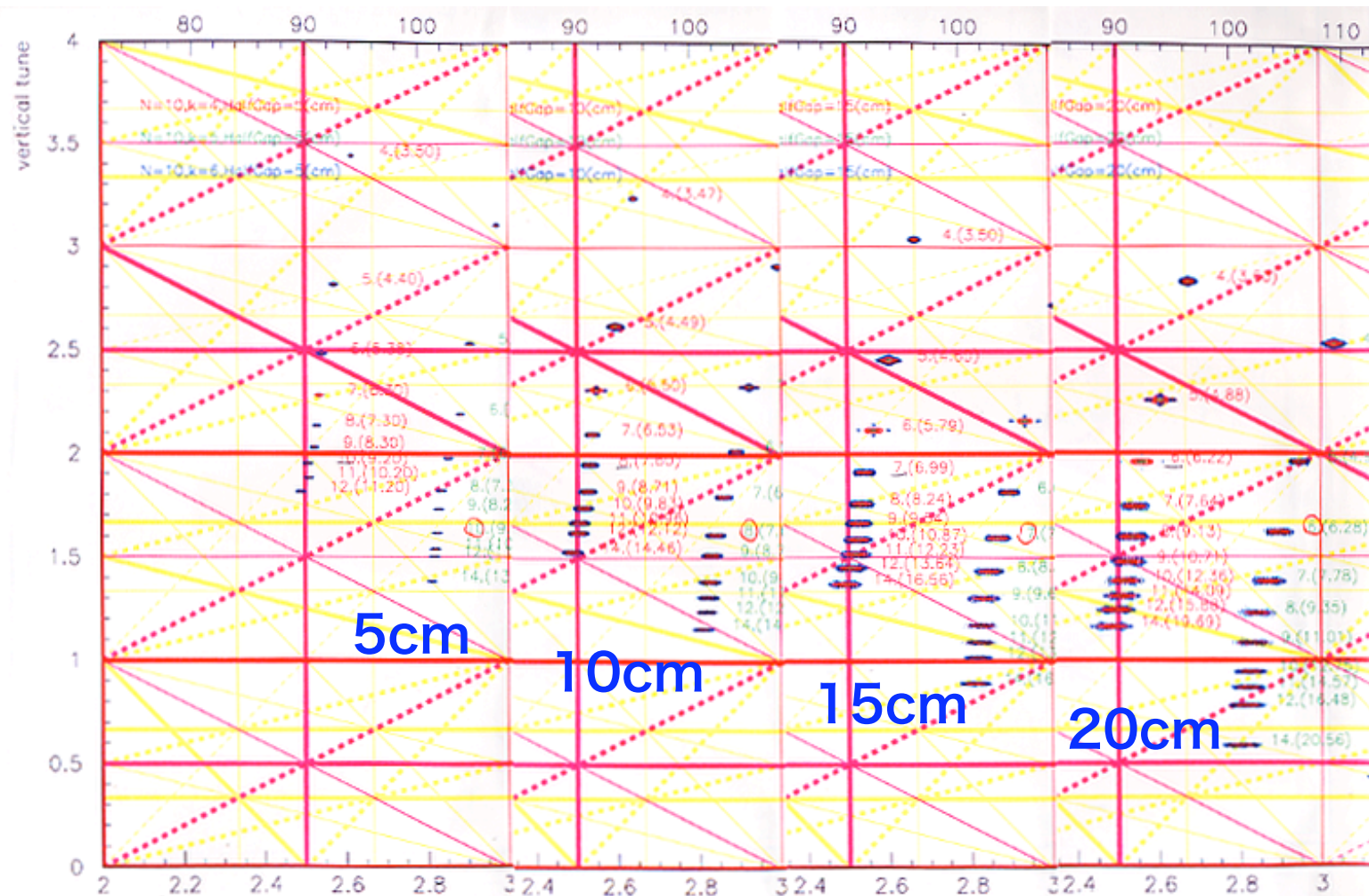

PRISM-FFAG

- N=10
- $k=5(4.6-5.2)$
- $F/D(BL)=6$
- $r_0=6.5\text{m}$ for $68\text{MeV}/c$
- half gap = 17cm
- mag. size 110cm @ F center
- Triplet
- $\theta_F=2.2\text{deg}$
- $\theta_D=1.1\text{deg}$
- tune
 - h : 2.71
 - v : 1.52

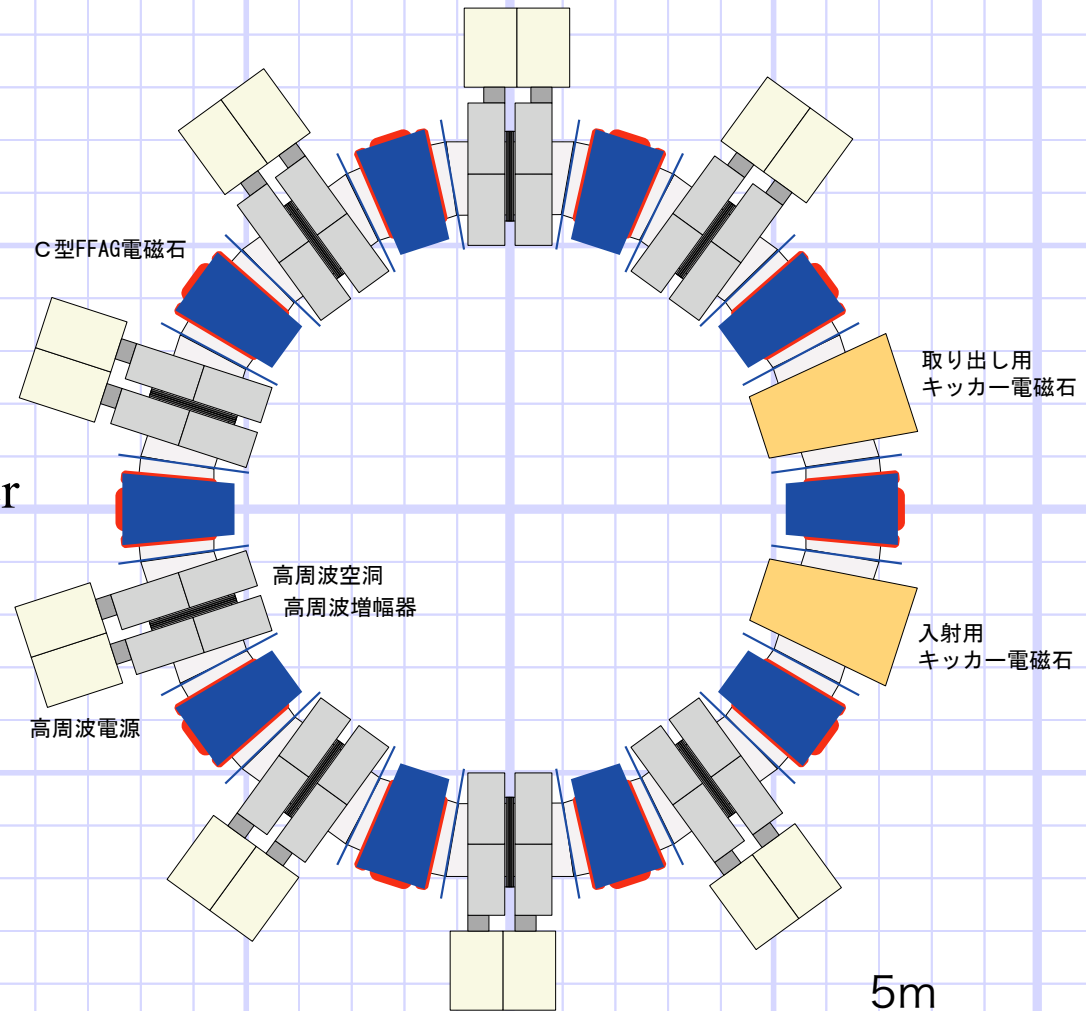

Magnet Design

Feature of PRISM-FFAG Magnet

scaling radial sector

Conventional type. Have larger circumference ratio.

triplet (DFD)

F/D ratio is variable. Ds have field crump effects to realize the large packing factor. the lattice functions has mirror symmetry at the center of a straight section.

large aperture

important for achieve a high intensity muon beam.

thin

Magnets have small opening angle. so FFAG has long straight sections to install RF cavities as mach as possible

trim coils

k value is variable. Therefore, not only vertical tune and also horizontal tune are tuneable.

C-shaped

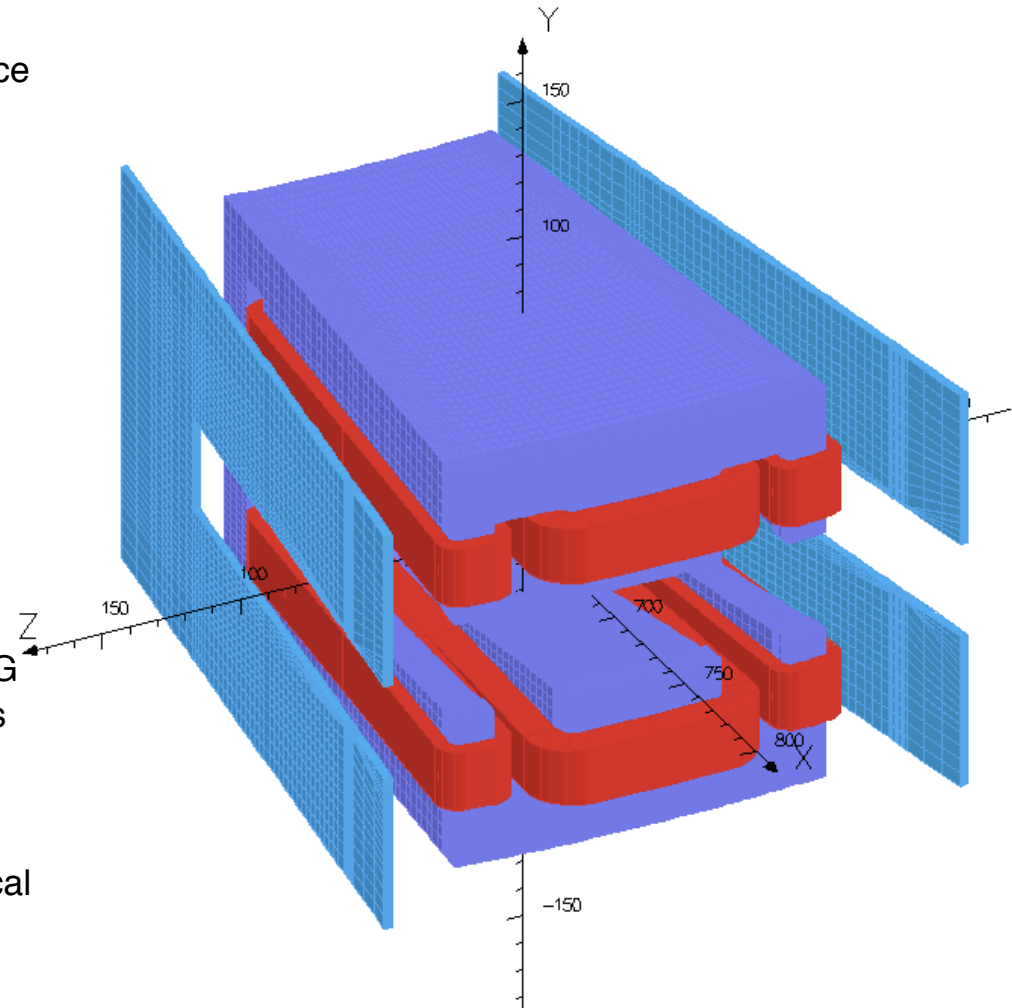

Parameters of PRISM-Magnet

r0	650 cm
Number of Cell	10
F/D ratio	4~8
k value	4.4~5.2
BL integral	8.6 T · m/half cell @ r=r0

Aperture

Horizontal	100 cm
Vertical	30 cm

top view

Field clamp

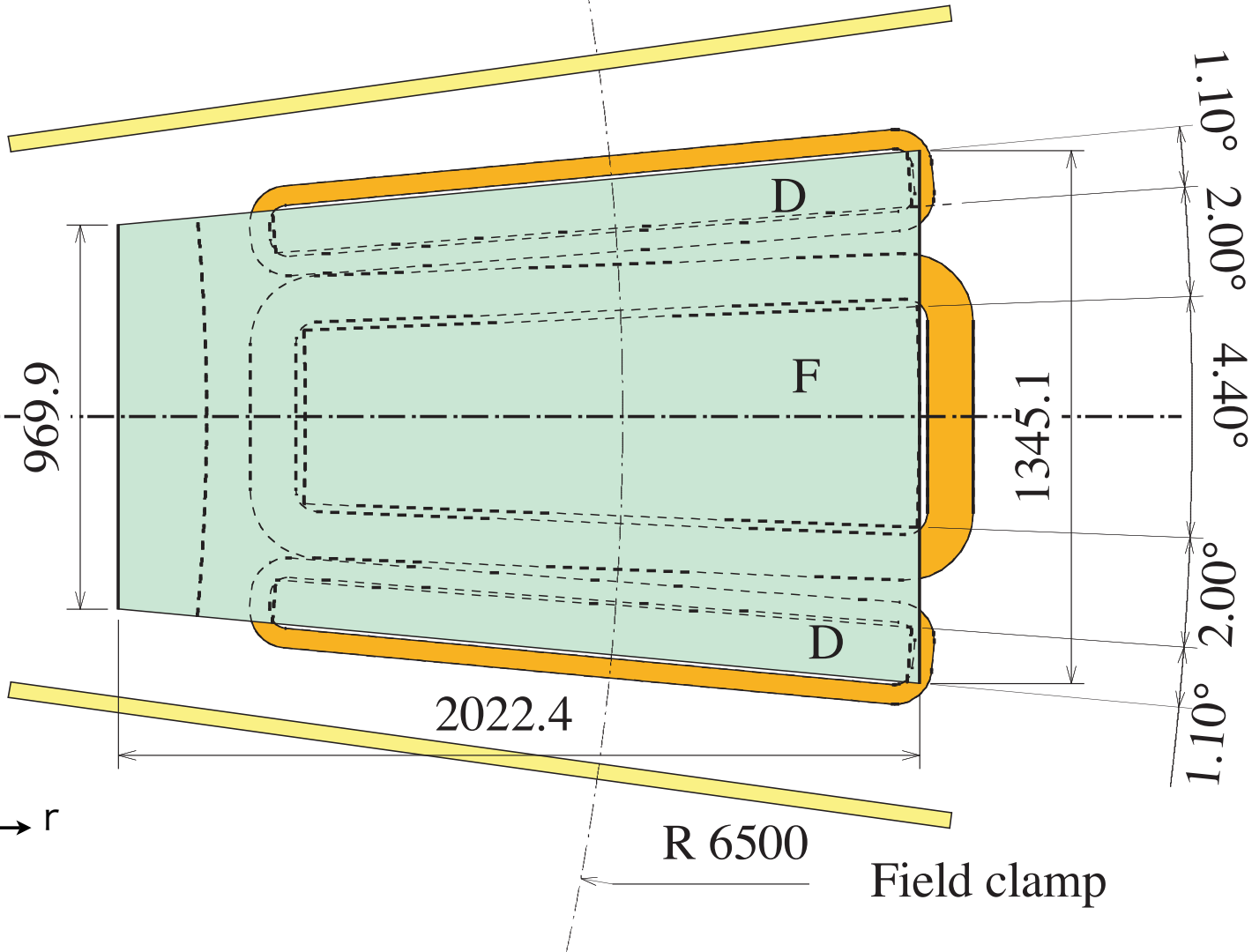
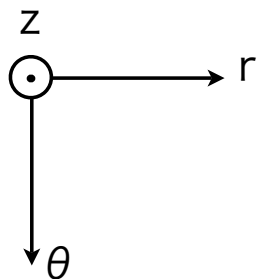

cross section at the center of F magnet

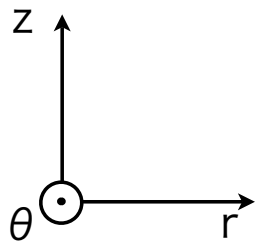
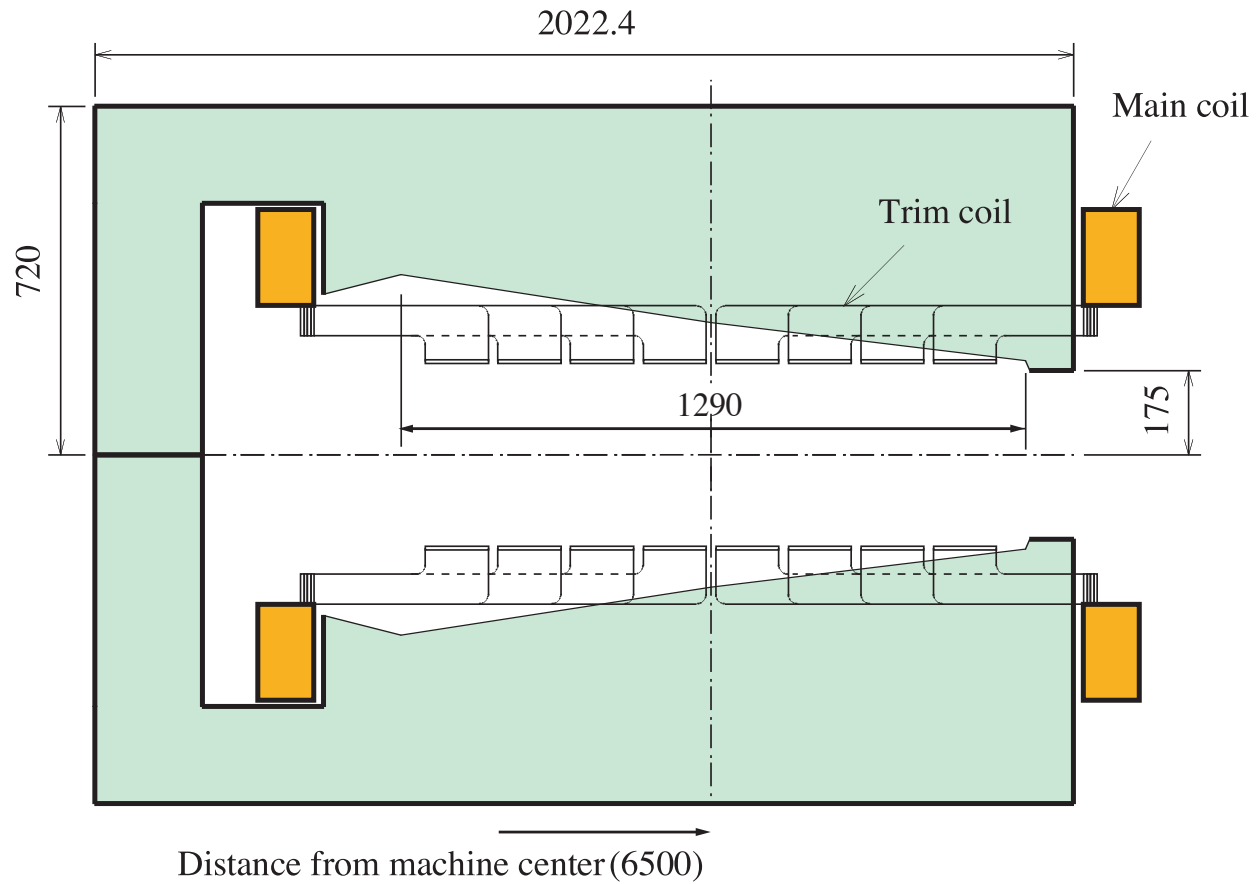

No anisotropic inter pole

coils

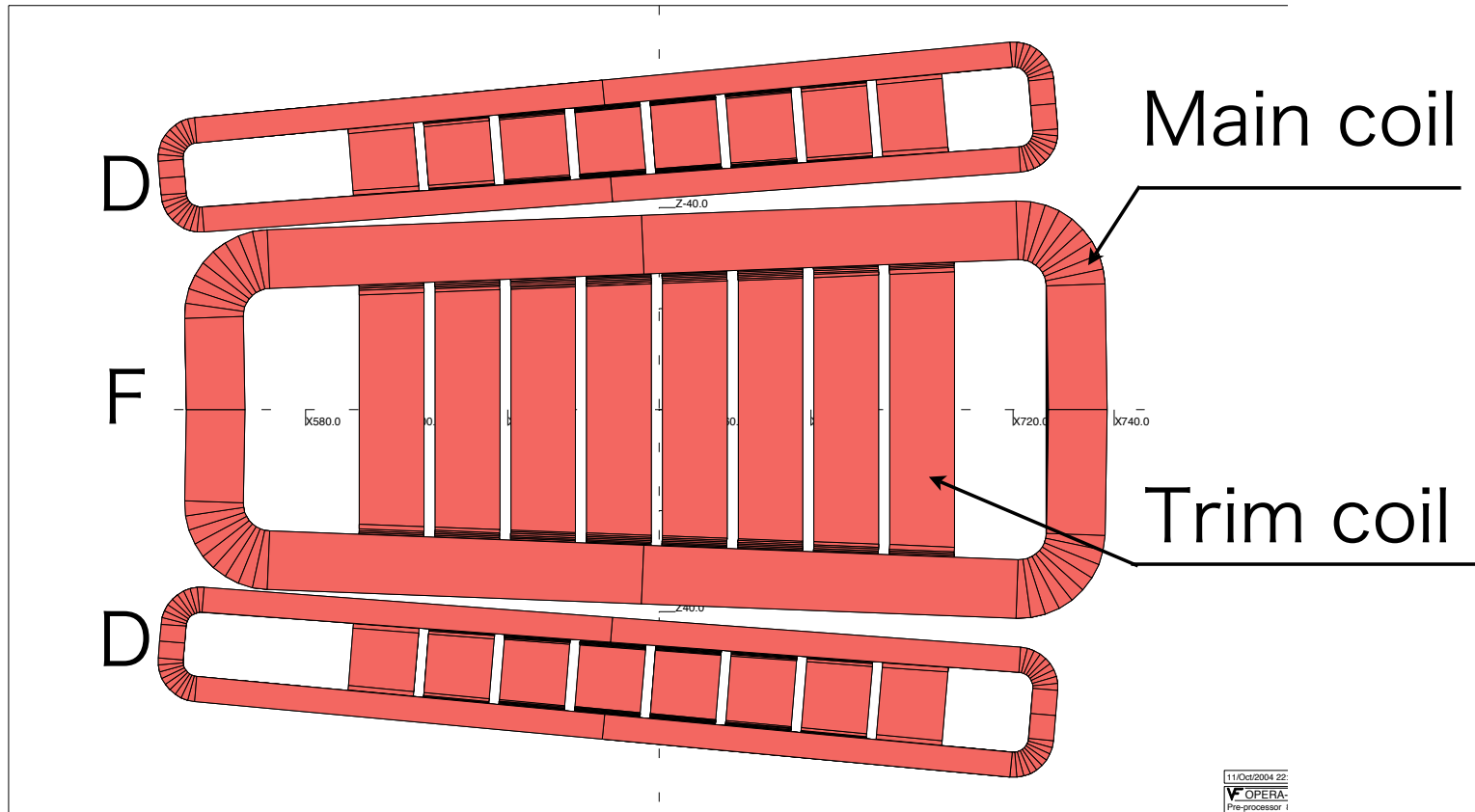

Effect of the flat trim coils

Cross section of Trim coils

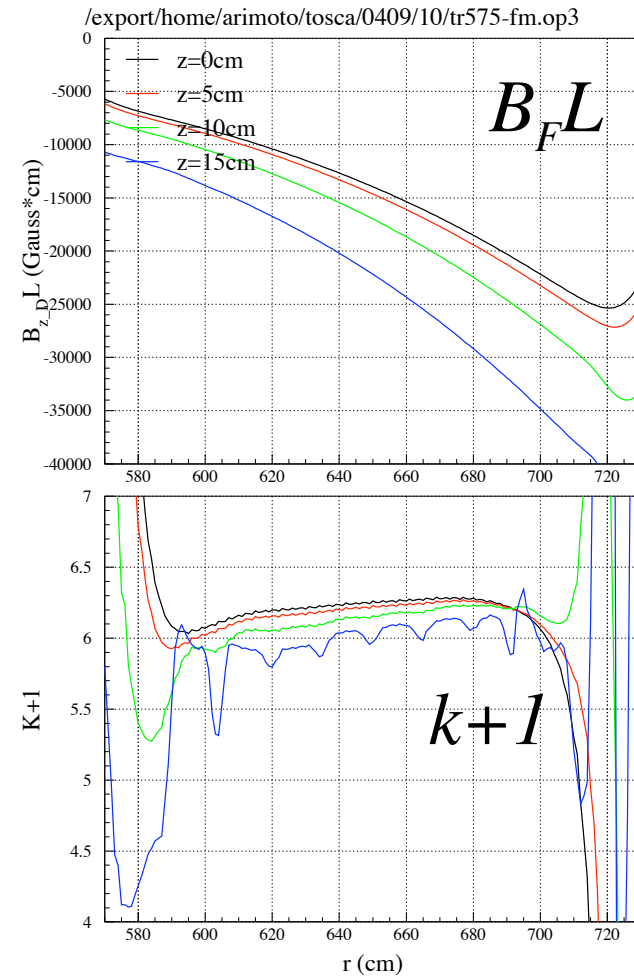
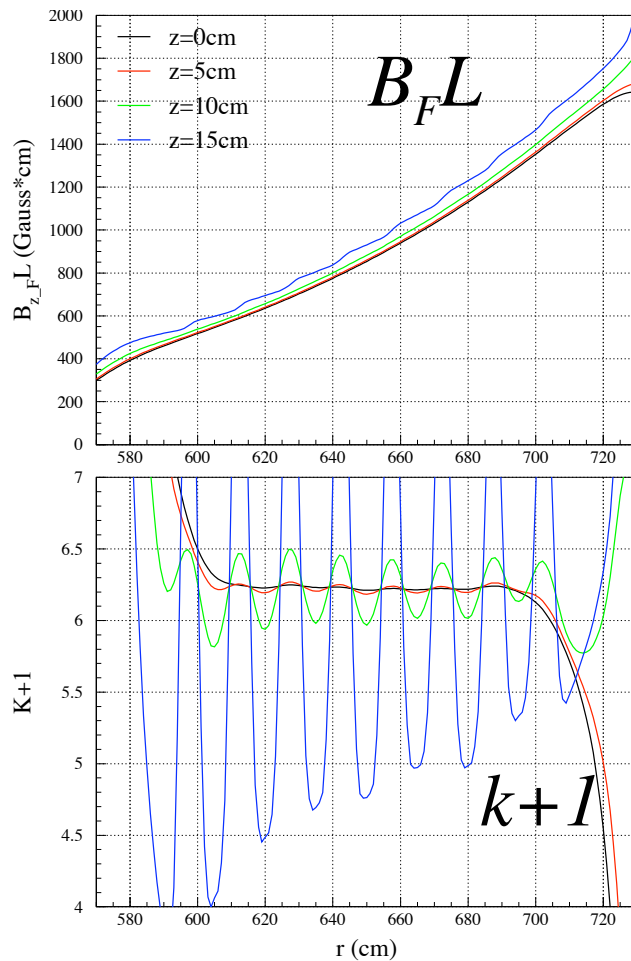

Field calc. by TOSCA (trim coil off)

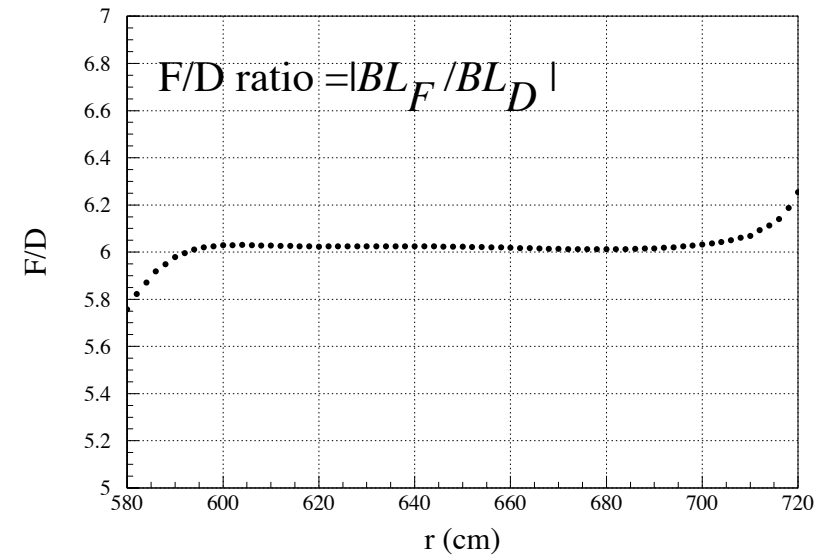
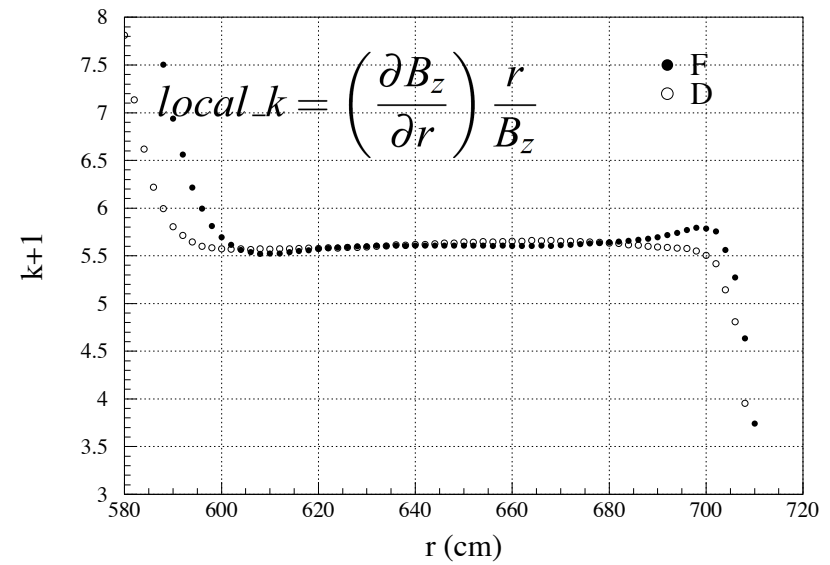
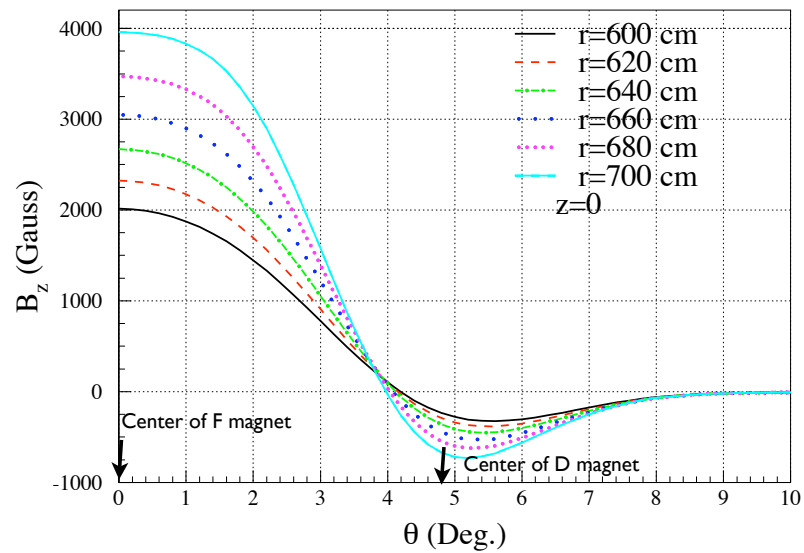

Parameters of PRISM-FFAG Magnet

- Total Mass of yoke: 14 t / cell
- F Main coil : 78000 A*T / coil (F/D=4)
- D Main coil : 26000 A*T / coil (F/D=4)
- F trim coil : 1200 A/coil
- D trim coil : 500 A/coil
- Electric Power for F Main coil : 740 kW/Ring
- Electric Power for D Main coil : 441 kW/Ring

FFAG Acceptance

4D Acceptance : 1G (mm mrad)^2

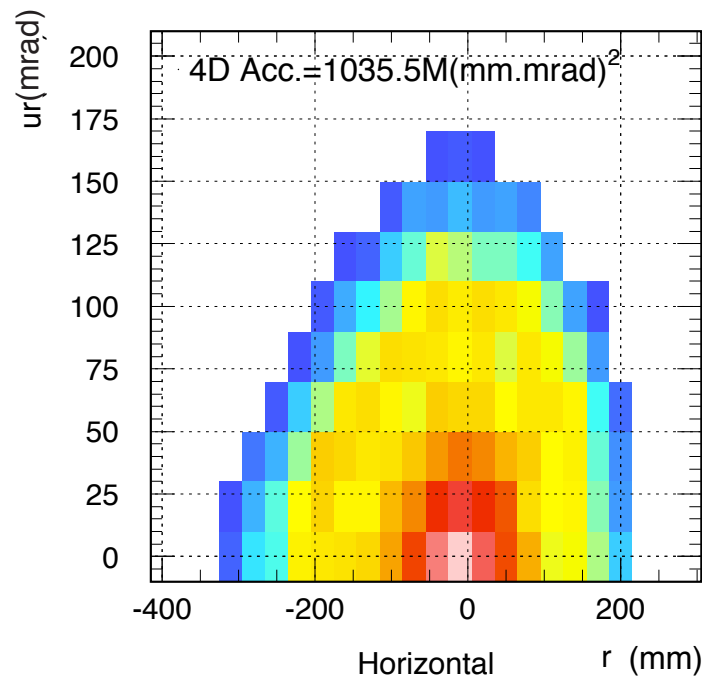

Horizontal Acceptance
 40000π mm mrad

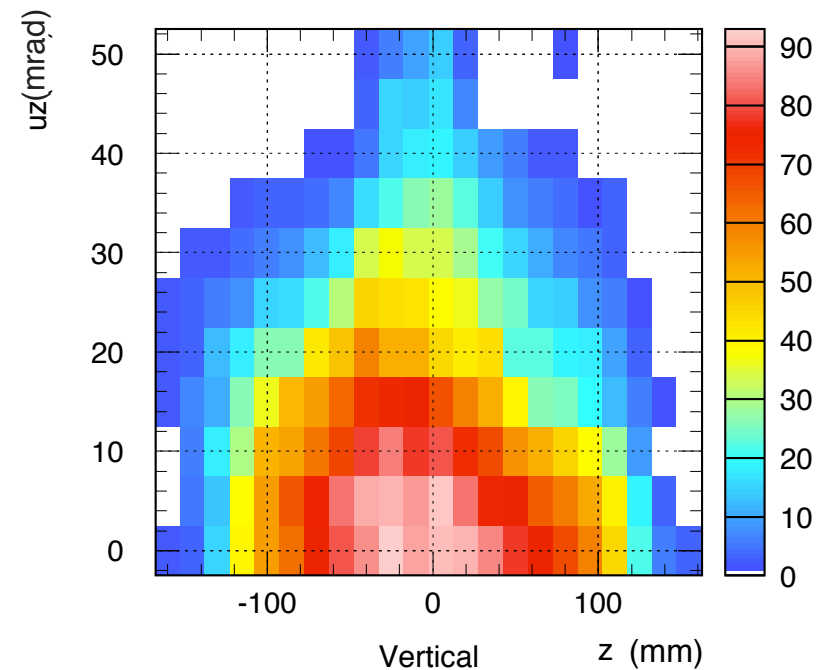

Vertical Acceptance
 6500π mm mrad

zero chromaticity

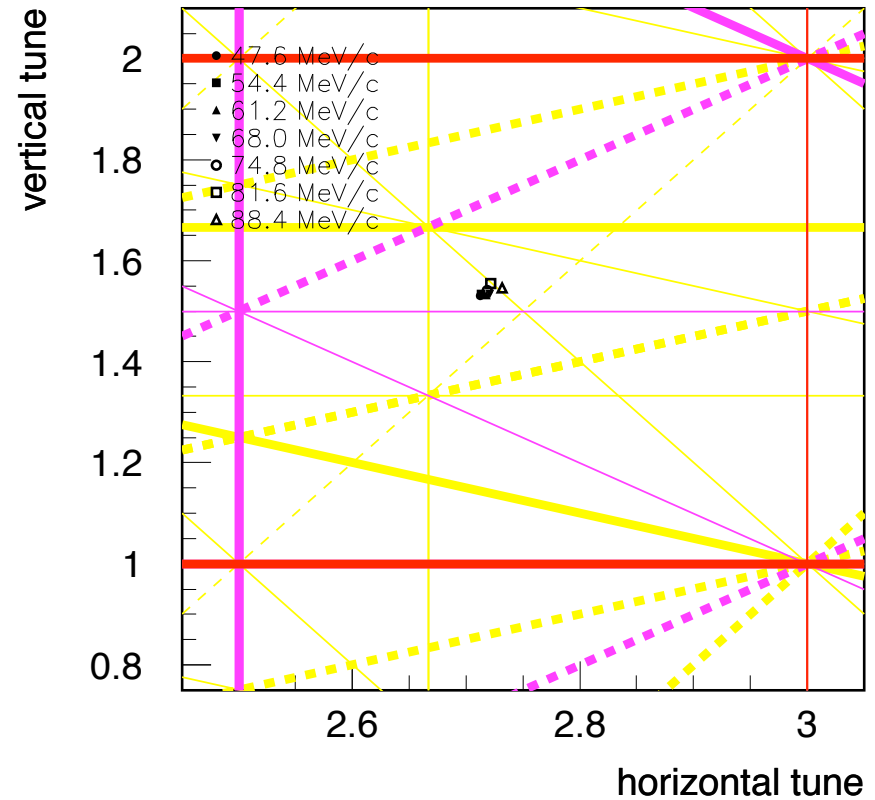
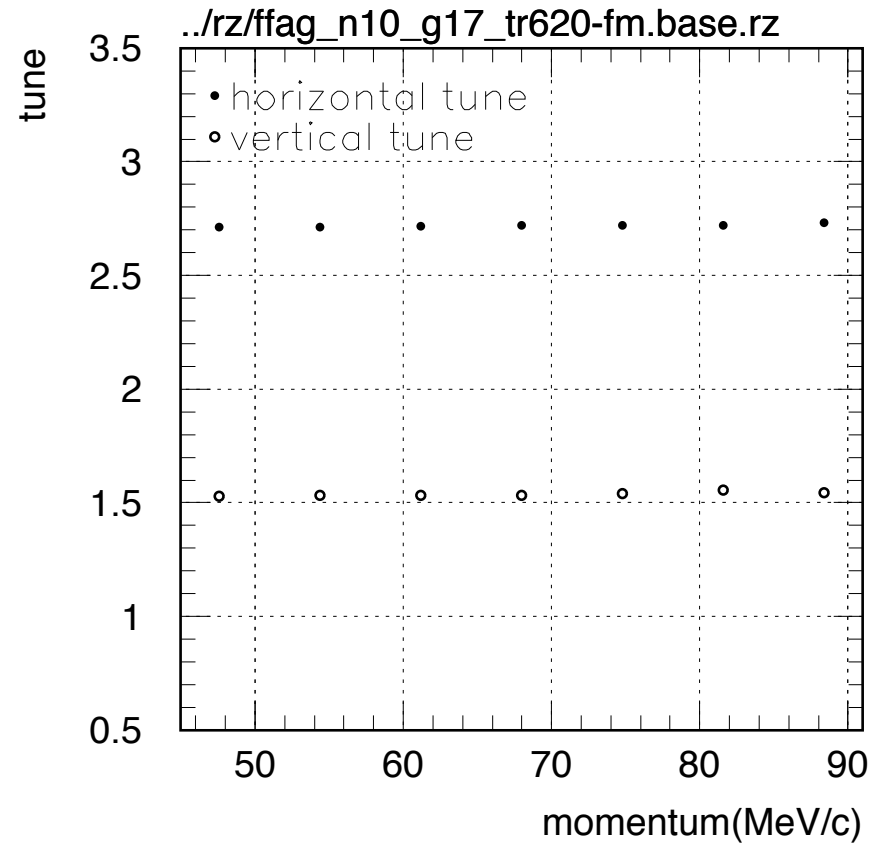

RF R&D

High field gradient RF

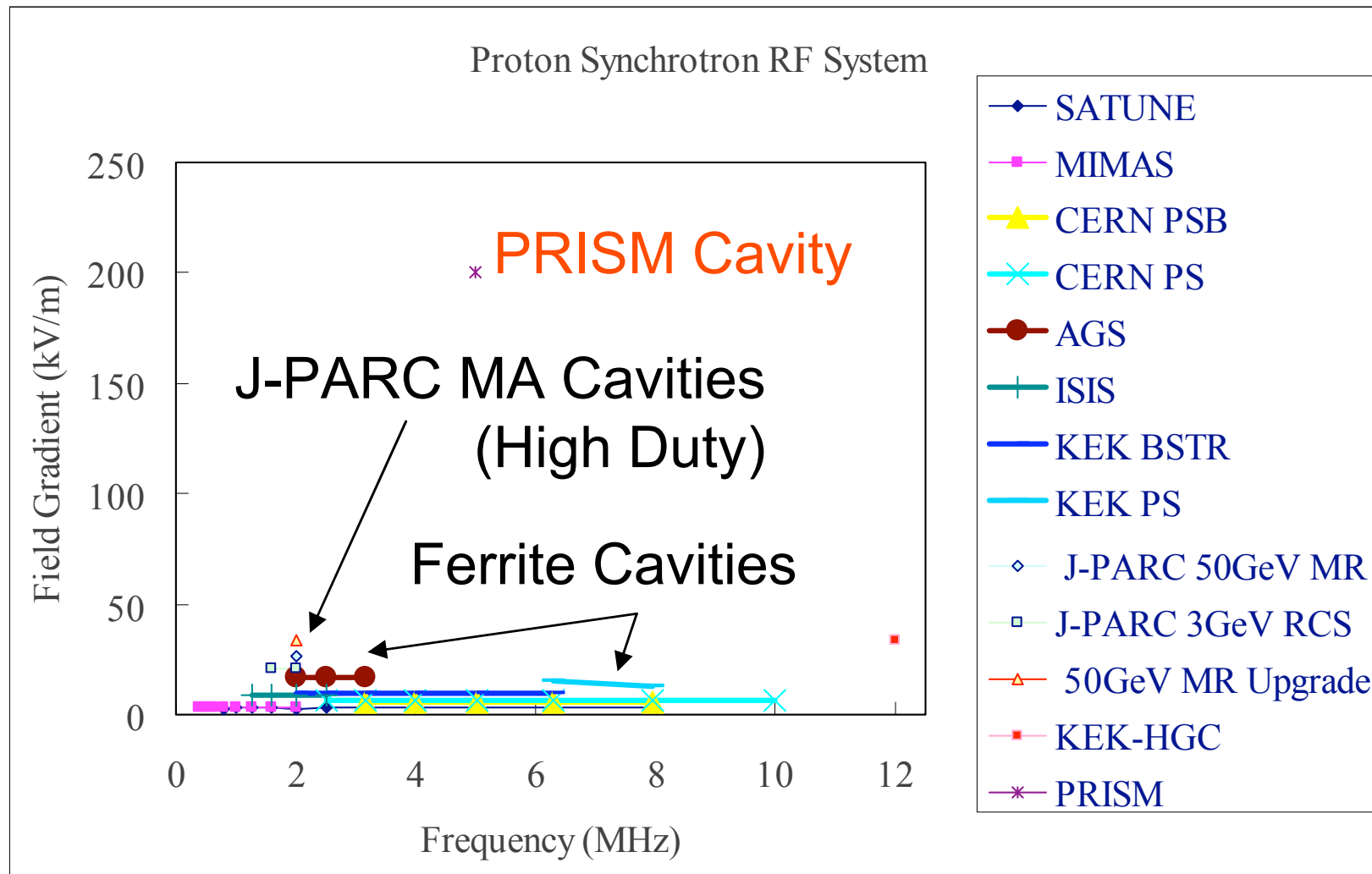

Parameters of RF system

Number of gap per cavity	5
	33cm/gap
Number of core per gap	6
core material	Magnetic Alloy
core shape	race track
core size	1.7m x 1.0m (inner 1.0m x 0.3m)
Shunt impedance	0.9kohm/gap
Field gradient	150~200kV/m
Flux density in core	~320 Gauss
Power tube	4CW100kE, DC33-37kV, 1.5MW(peak for 10us), Max current 60A
	Air cooling (duty 0.1%)

RF core (Magnetic Alloy)

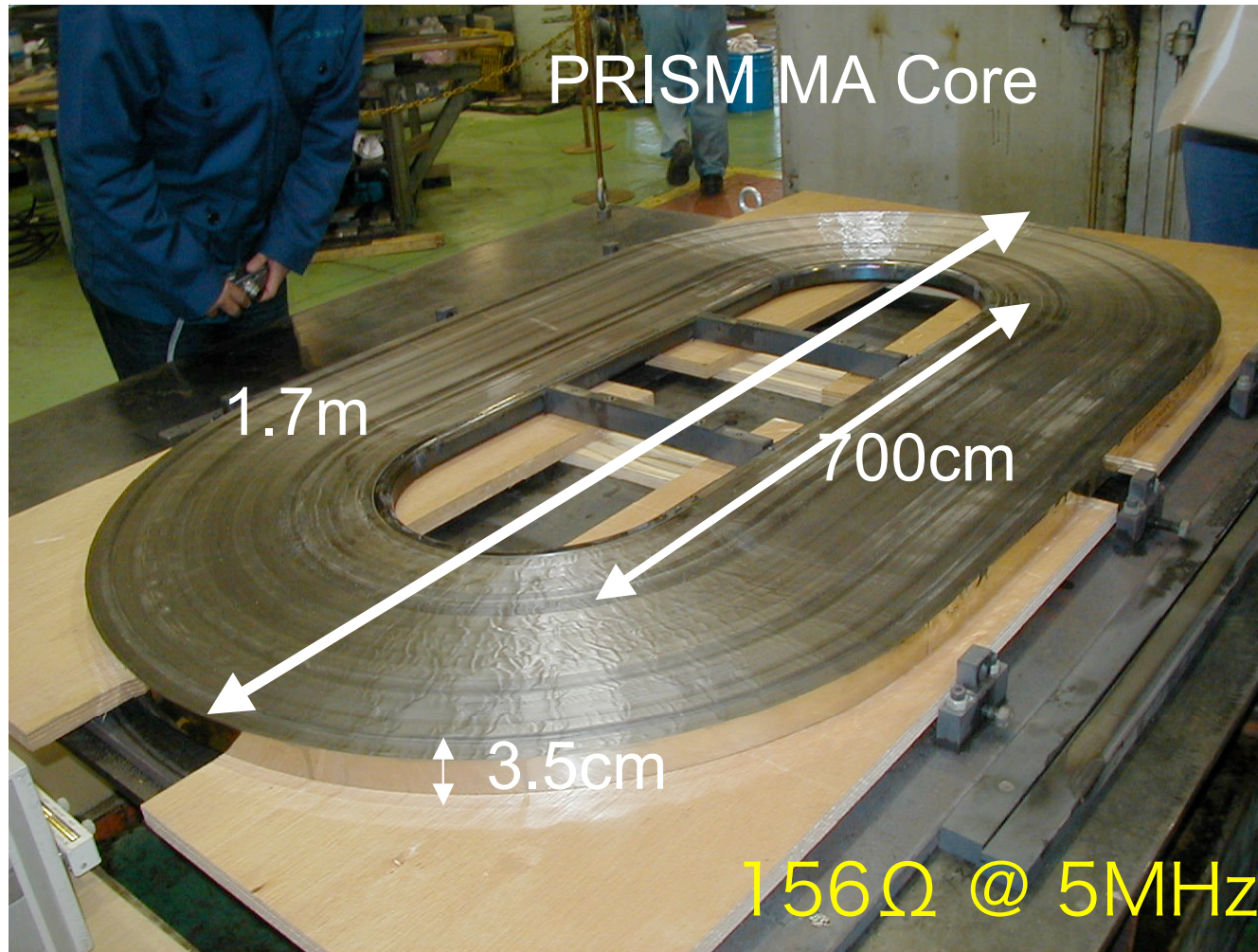

PRISM-RF System

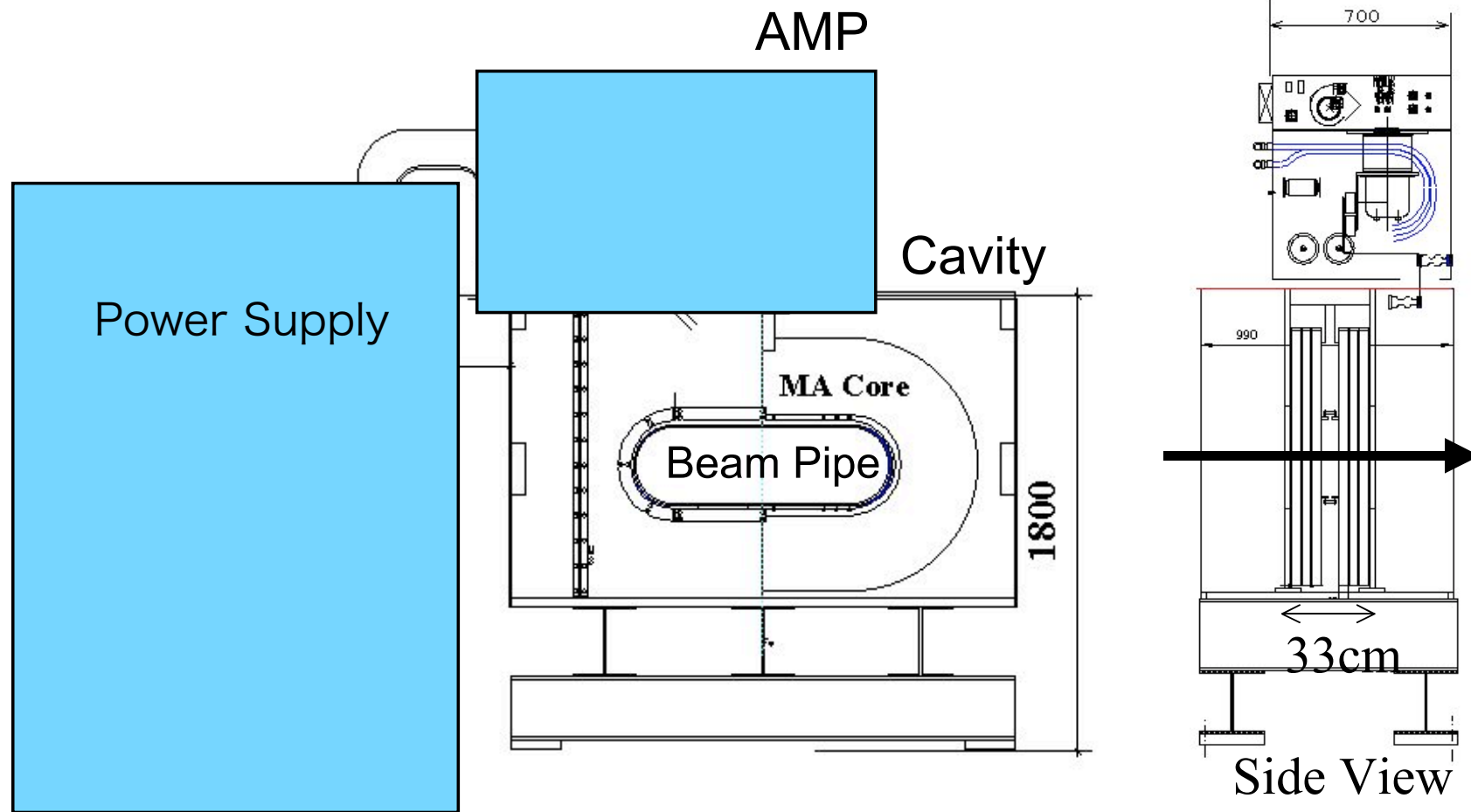

A Prototype cavity with 1 gap will be ready by the end of this JFY.

By C. Ohmori, Y. Kuriyama

RF AMP R&D

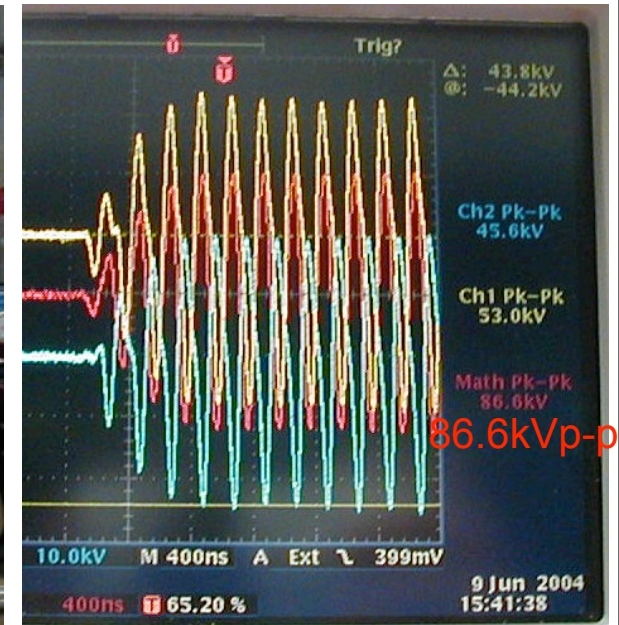
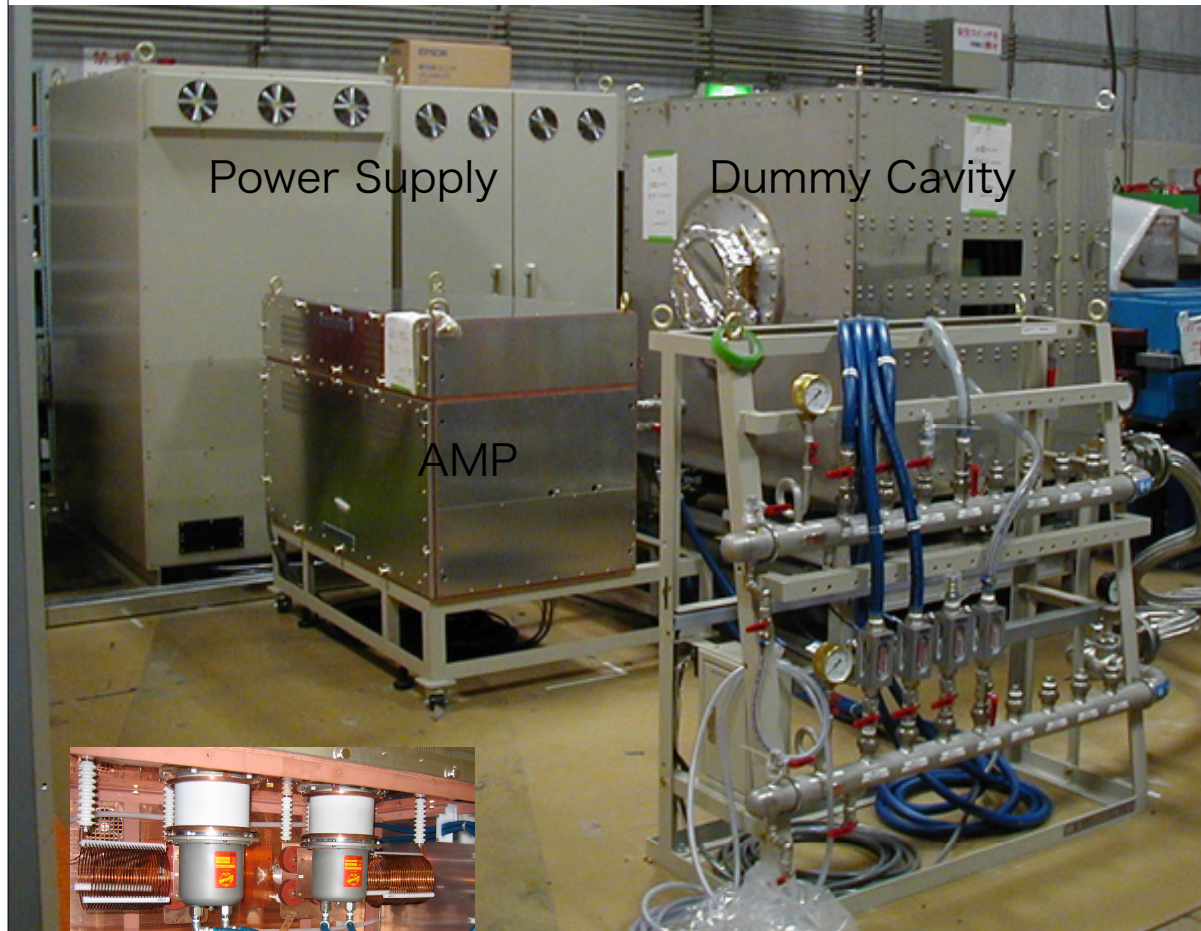

43kV/gap
w/ 734Ω dummy cavity
@5MHz

expected gradient
w/ PRISM-cavity (900Ω)
165kV/m

Phase Rotation Simulation

momentum spread

$$\Delta p/p = \pm 2\%$$

needs 6 turns ($=1.5\mu s$)

survival rate (68MeV/c)

$$\mu : 0.56$$

$$\pi : <10^{-23}$$

no pion

contamination

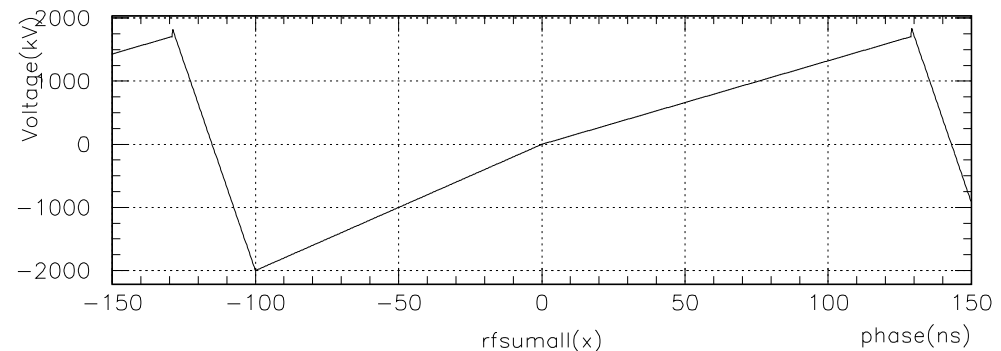
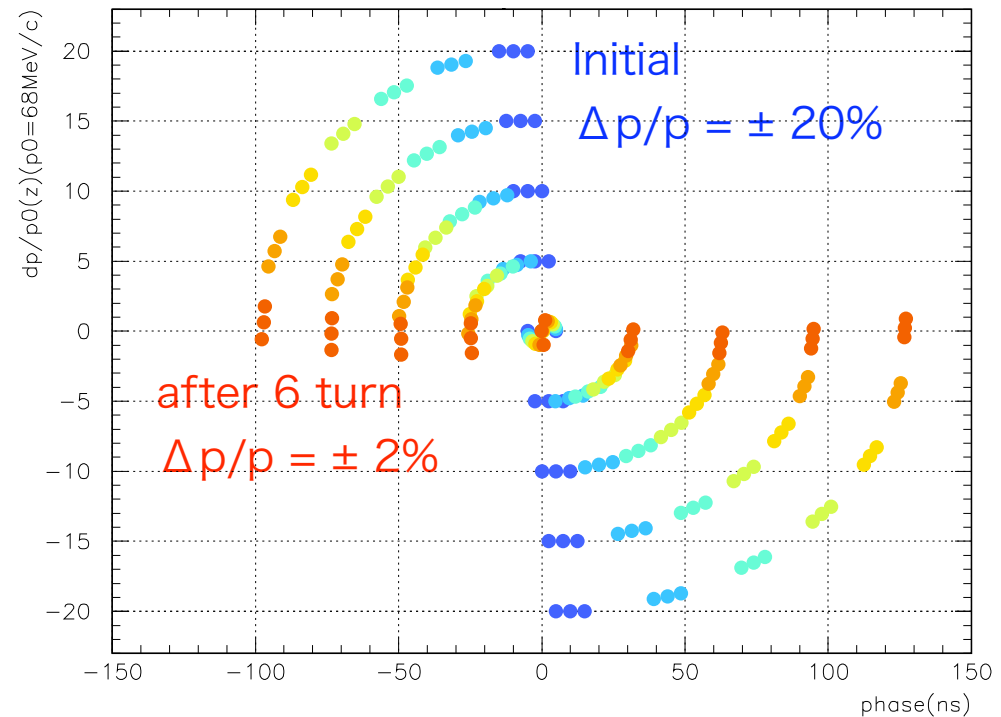

Simulation result
field gradient = 152kV/m

summary

- **PRISM** will provide super muon beam : low energy, high intensity, narrow energy spread and high purity.
- PRISM-FFAG construction has started in JFY 2003 as a 5-year program.
 - Optics design : large acceptance achieved
 - Magnet design : completed
 - RF system : more than 156kV/m is promised

injection and extraction are issues