

# *Feasibility Study of Hybrid Accelerator and Superconducting FFAG*

**Mitsubishi Electric Corporation, H. Tanaka**

## Contents

- Hybrid Accelerator
  - Acceleration scheme
  - Laptop Accelerator
  - Proton or Carbon therapy
- Superconducting FFAG using untuned RF cavity

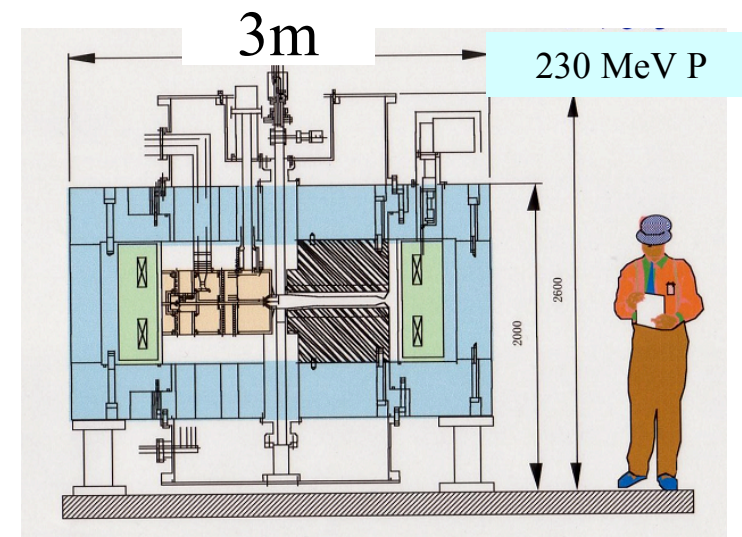
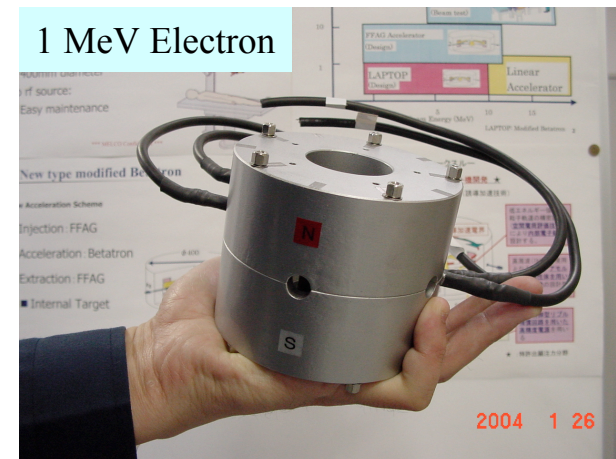

- Combination between FFAG and synchrotron
- Both magnetic fields and closed orbits are changed

$$P = eBR$$

$$\frac{dP}{dt} = eR \frac{dB}{dt} + eB \frac{dR}{dt}$$

**Momentum**

**Magnetic Field**

**Closed Orbit**

**Synchrotron**

**FFAG**

**Betatron**

**Cyclotron**

	FFAG	Hybrid	Synchrotron
Energy Gain	△	○	○
Peak Current	○	○	△
Repetition	○	△	△

Injector of a synchrotron

When repetition rate of magnet is high, average beam current is fairly high. → Laptop accelerator

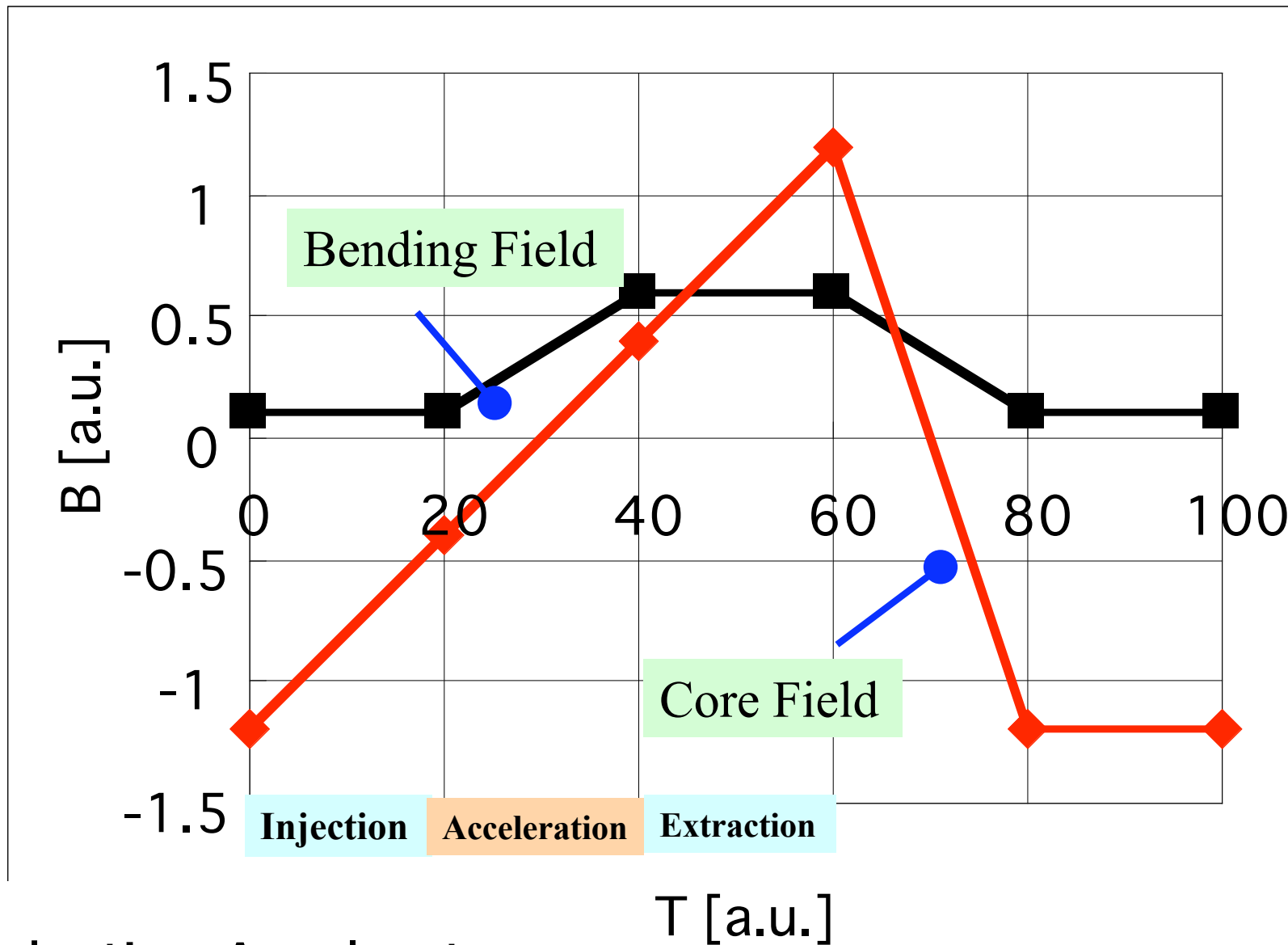

■ Induction Accelerator

- Injection:
  - ◆ Continuous Injection
- Acceleration:
  - ◆ Betatron Acceleration
- Extraction:
  - ◆ Continuous Extraction

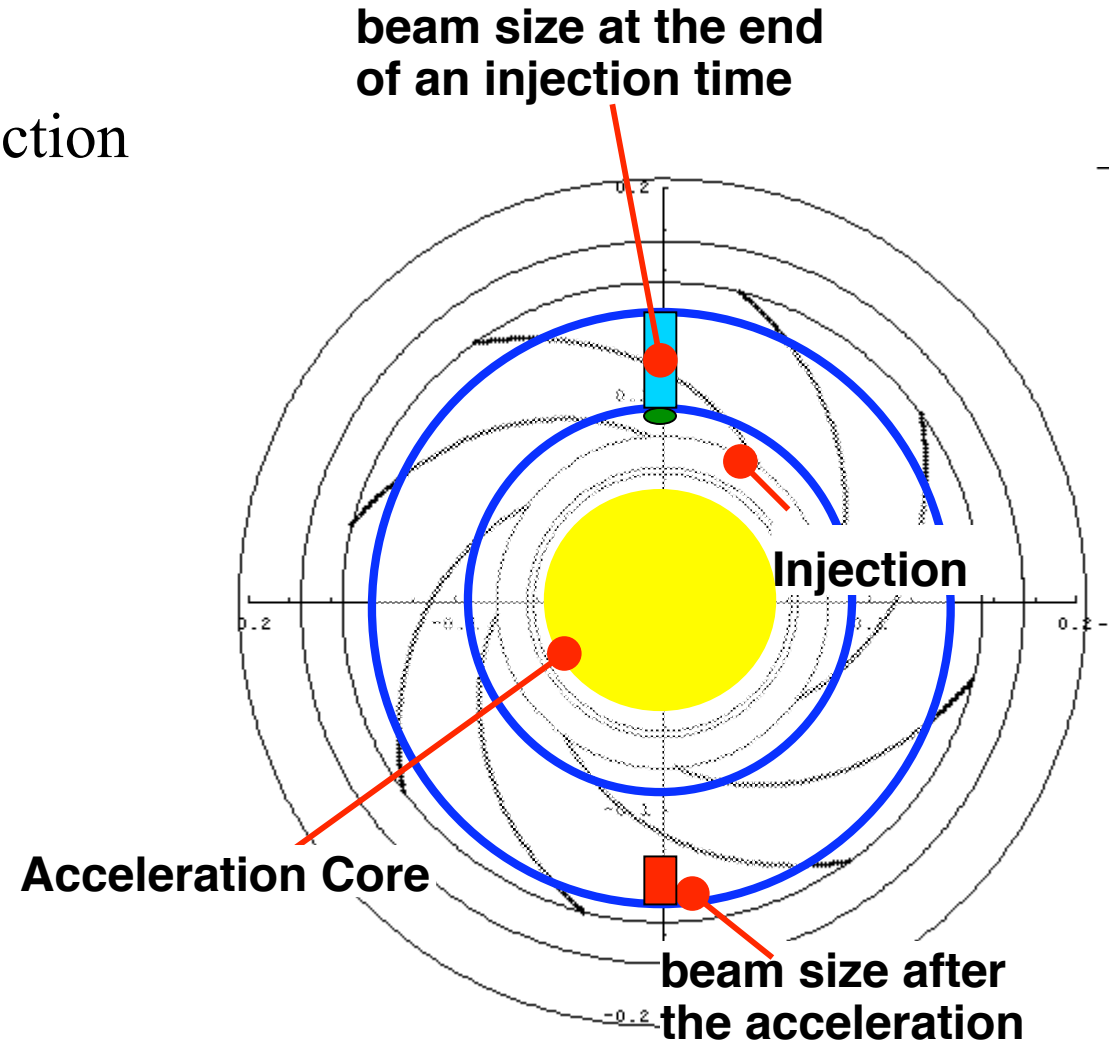

$$2 \Delta B(\text{on one orbit}) = \Delta B \text{ (average field interior the orbit)}$$

- Betatron acceleration condition is satisfied on one orbit.
- Other orbits move outer or inner during an acceleration.

$$B_{orbit} = B_0 \left( \frac{r}{r_0} \right)^k$$

$$B_{acc} = B_c \left( \frac{r_c}{r} \right)^2 + B_0 \left( \frac{2}{(k+2)r_0^k} \right) \frac{r^{k+2} - r_i^{k+2}}{r^2}$$

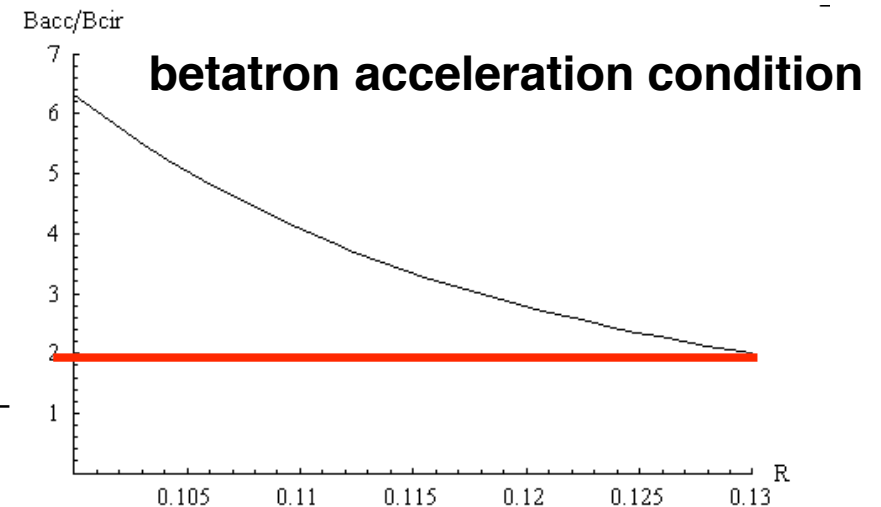
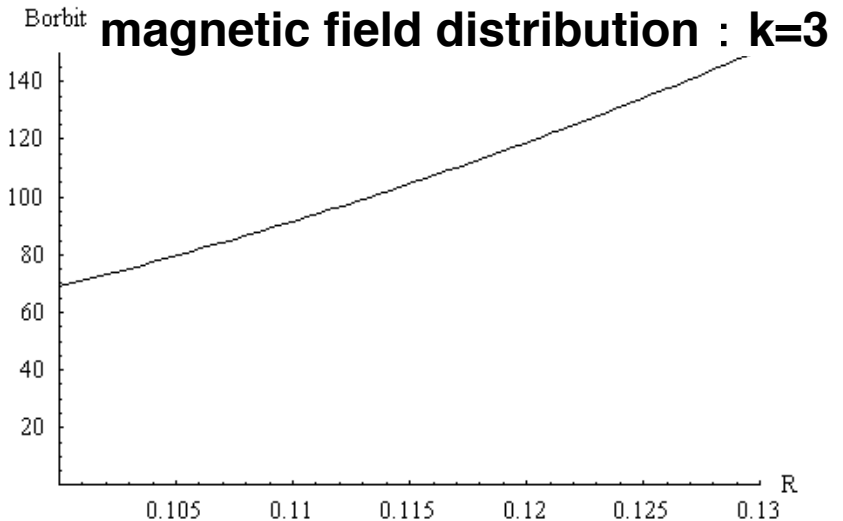

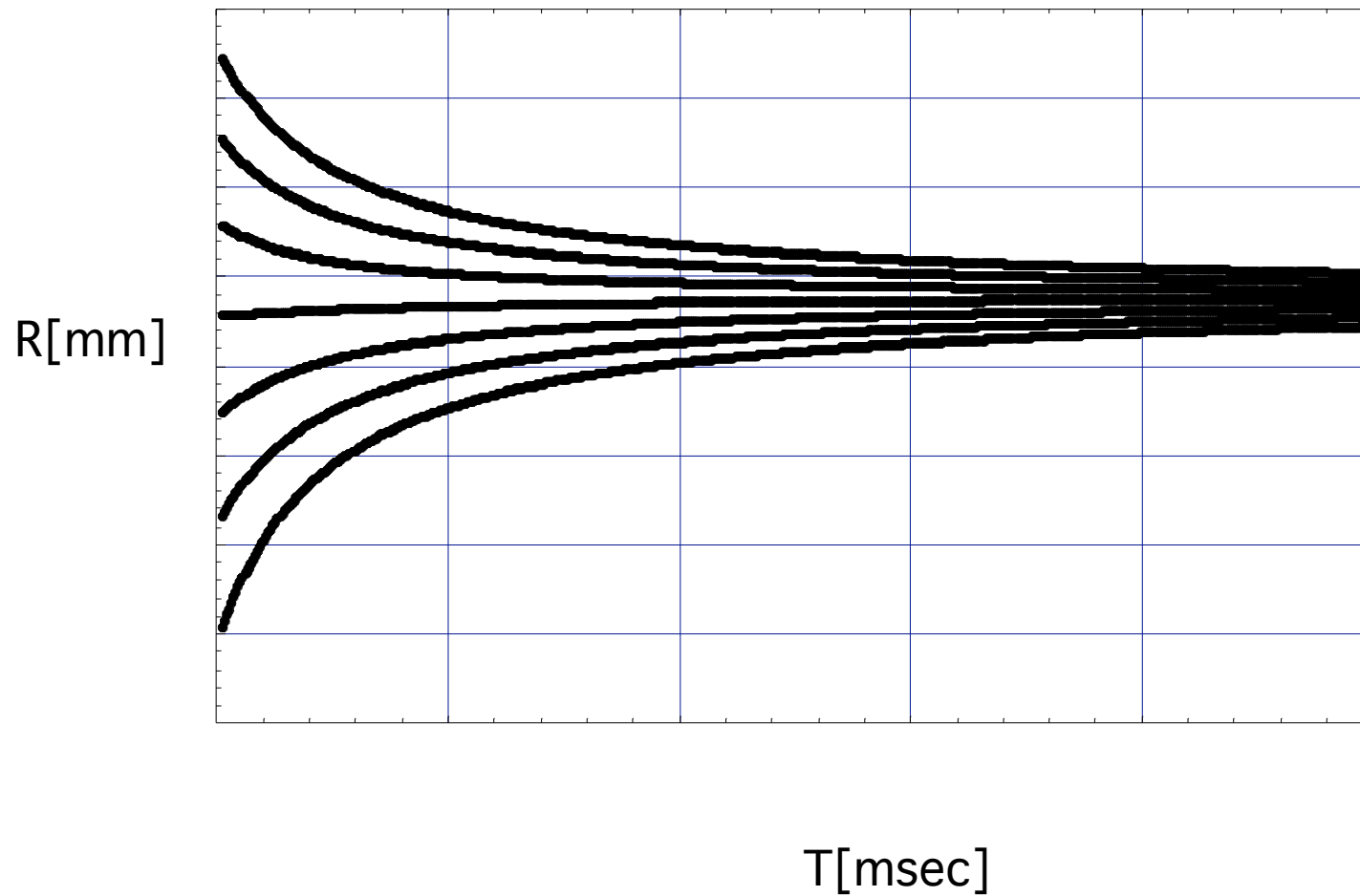

Beam simulation results

1. Low price
2. Compact: Circular accelerator
  - $\phi$  100 size
3. No rf source: Induction accelerator
  - Easy maintenance
4. Energy
  - 1 MeV /Electron

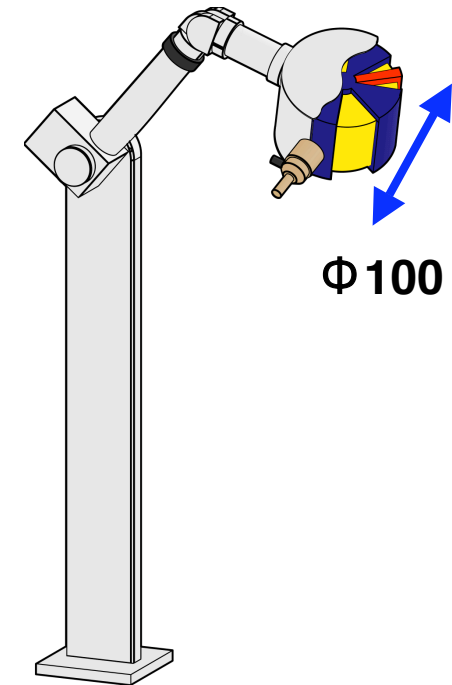

Maximum Energy	1 MeV
Injection Energy	60 keV
Particle	electron
Magnet Type	Spiral Sector
No of Sectors	5
K value	0.8
Orbit Radii	23mm~28.3mm
Betatron tunes	$\nu_x=1.85, \nu_y=0.8$
Repetition Rate	1 kHz

# Magnetic Pole Shape of the Spiral Magnet

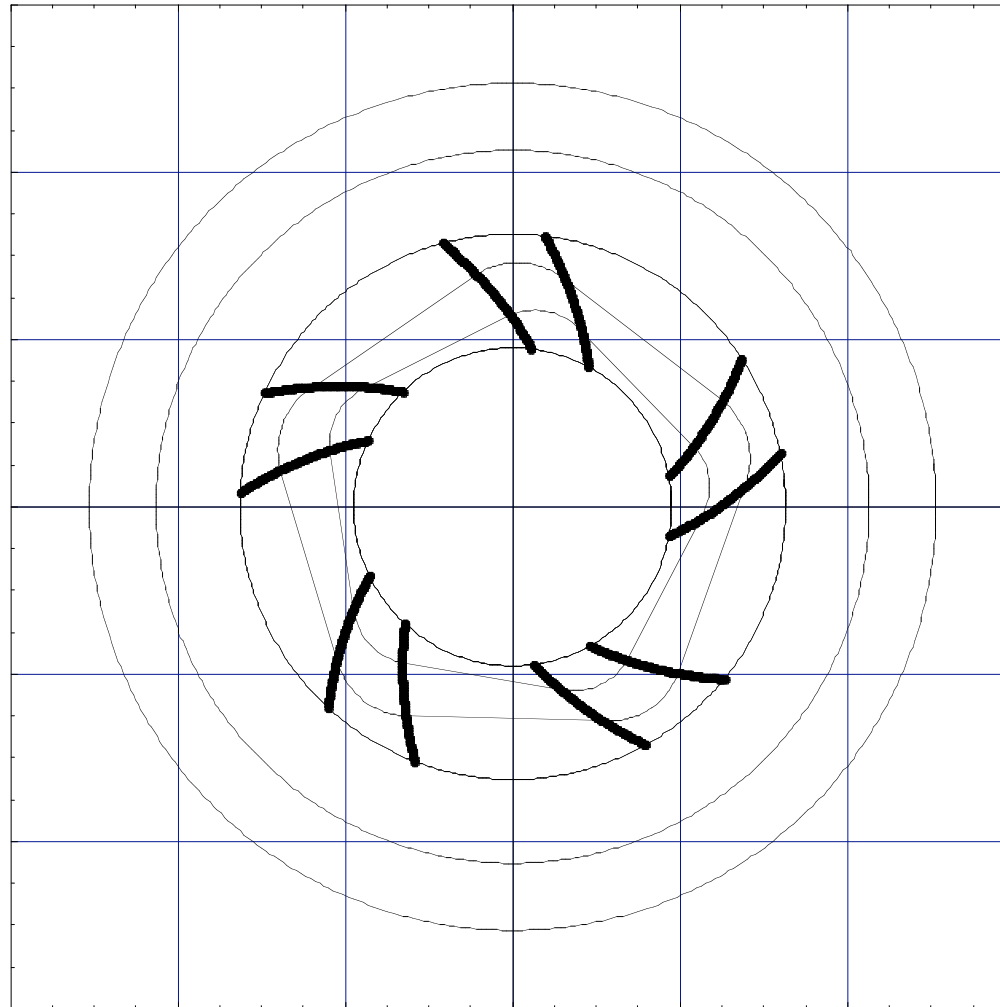

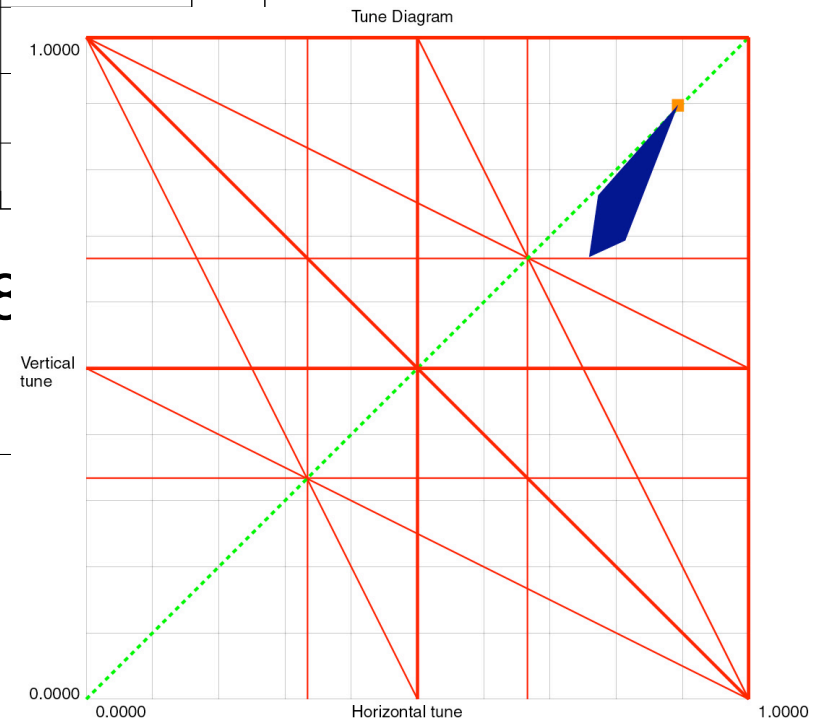
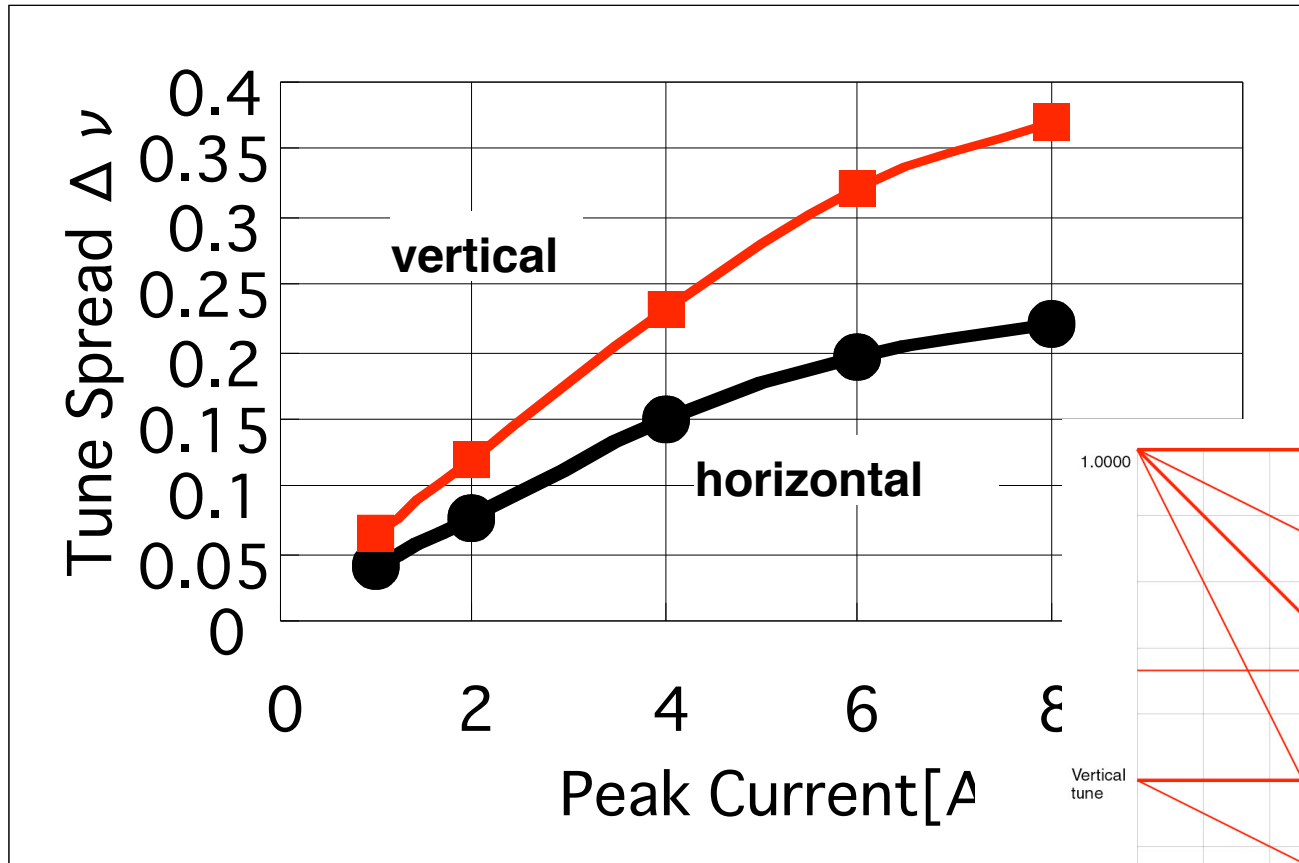

**Tune diagram at the injection**

Diameter	100 mm
Height	80 mm
Magnetic field	0.59T
Spiral Angle	35 degree
Packing Factor	0.3
Gap	7.5mm~5.4mm
Coil turns	7 turn/pole
Coil current	250 A
Inductance	0.072 mH
Material	MBS-318 ※

※ Mitsubishi Materials bonded soft magnetic material

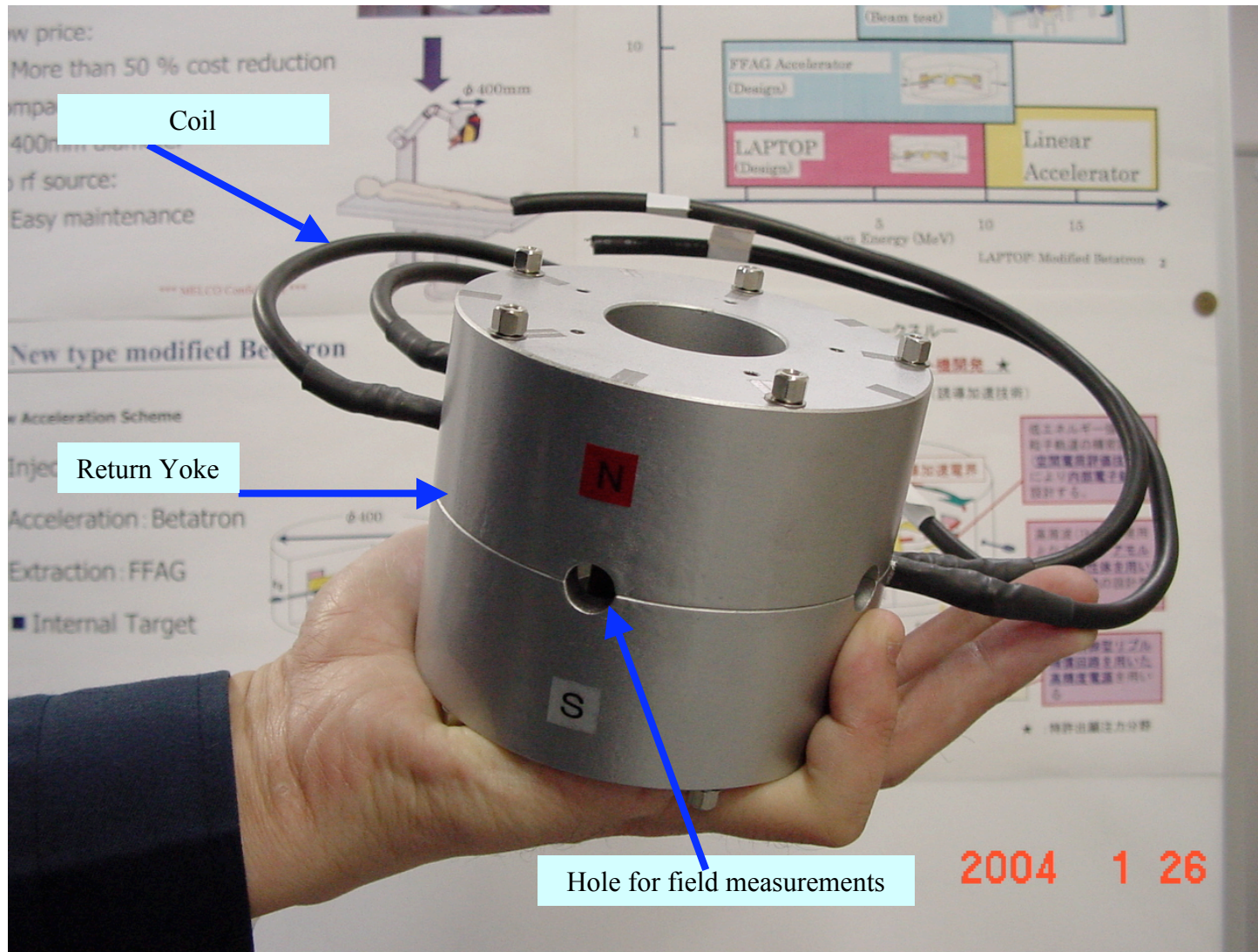

The present study is partially supported by the REIMEI Research Resources of Japan Atomic Energy Research Institute.

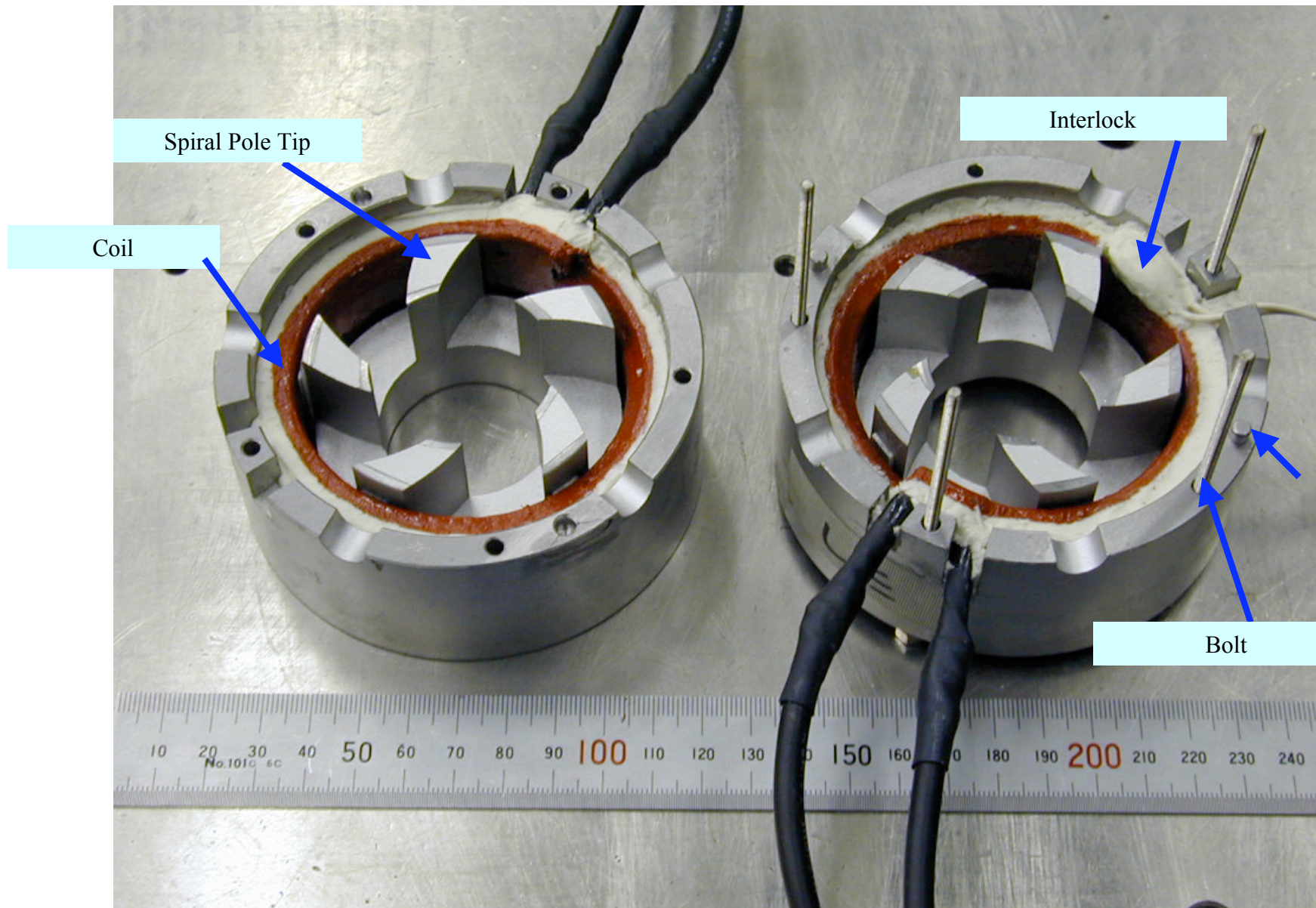

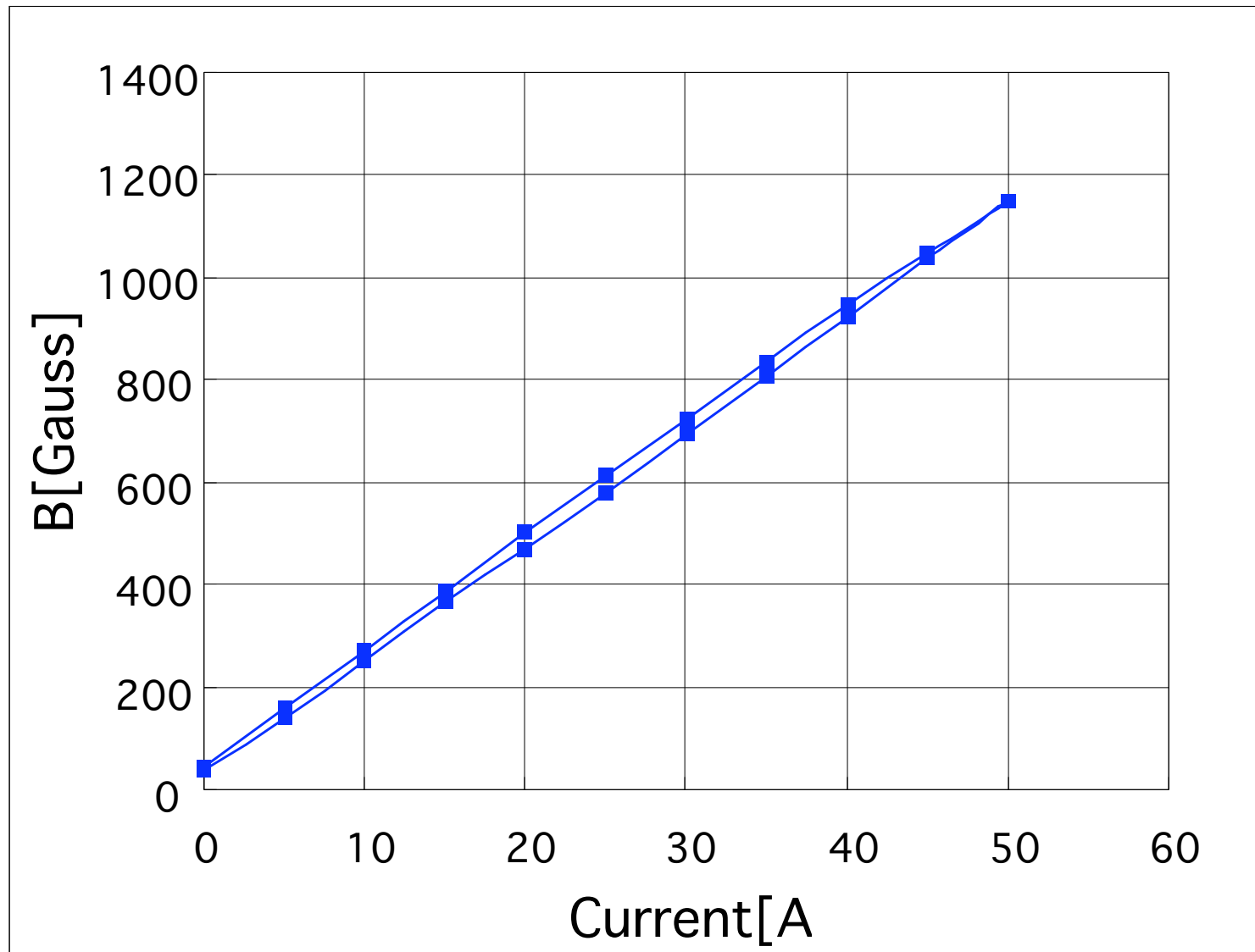

Coil current 50A-400Hz (Full spec : 250A-1kHz)

## ■ **Electron Gun and Injection System:**

- **Continuous injection  $\Rightarrow$  new type electron gun**

## ■ **Vacuum Chamber:**

- **Thin coated glass**

<b>Particle</b>	<b>C4+</b>
<b>Energy</b>	<b>0.035~7</b>
<b>Radii</b>	<b>[MeV/n] 1.35~1.8[m]</b>
<b>Cell</b>	<b>8</b>
<b>K value</b>	<b>0.7</b>
<b>Lattice type</b>	<b>DFD lattice</b>
<b>RF Voltage</b>	<b>5 kV</b>
<b>Repetition</b>	<b>0.5Hz</b>

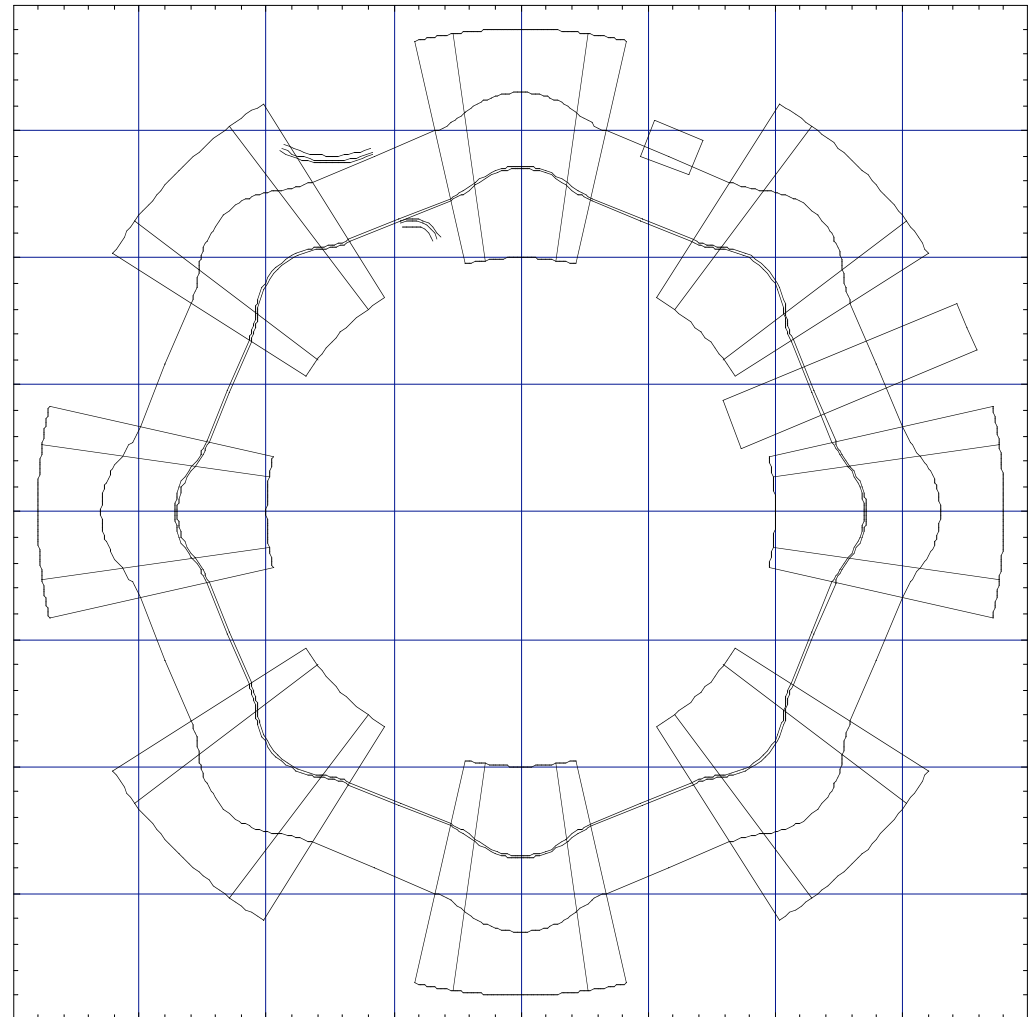

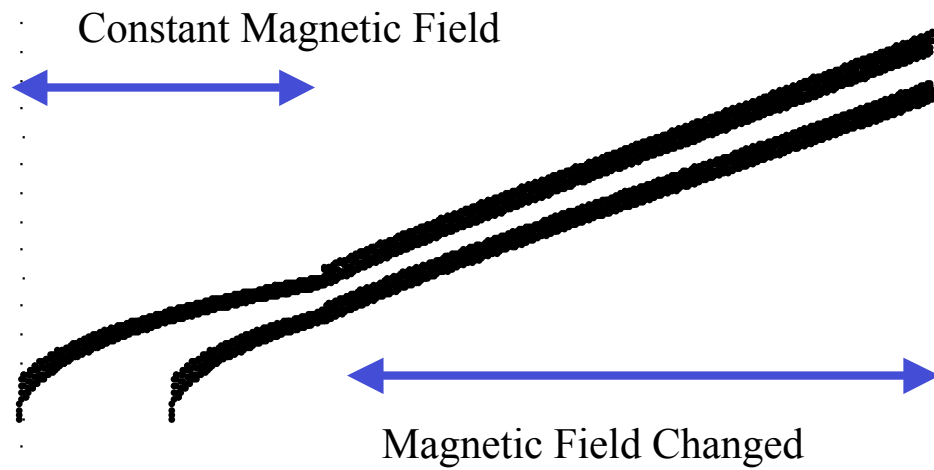
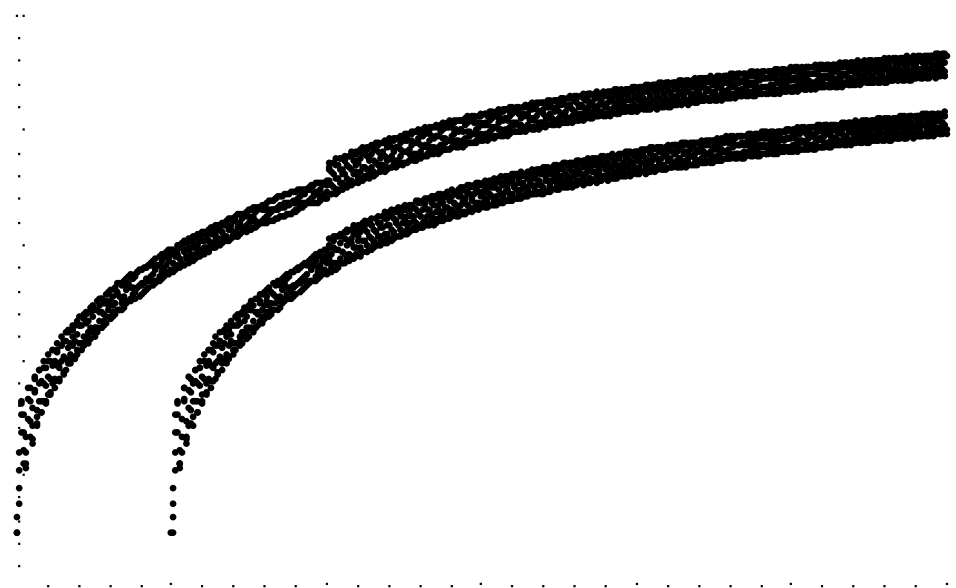

<b>Particle</b>	<b>C6+</b>
<b>Energy</b>	<b>4~400 [MeV/n]</b>
<b>Radii</b>	<b>7.00~7.48[m]</b>
<b>Cell</b>	<b>16</b>
<b>K value</b>	<b>12</b>
<b>Spiral angle</b>	<b>65 degree</b>
<b>Packing F</b>	<b>0.45</b>
<b>Maximum Magnetic Strength</b>	<b>1.9T</b>
<b>Repetition</b>	<b>0.5Hz</b>

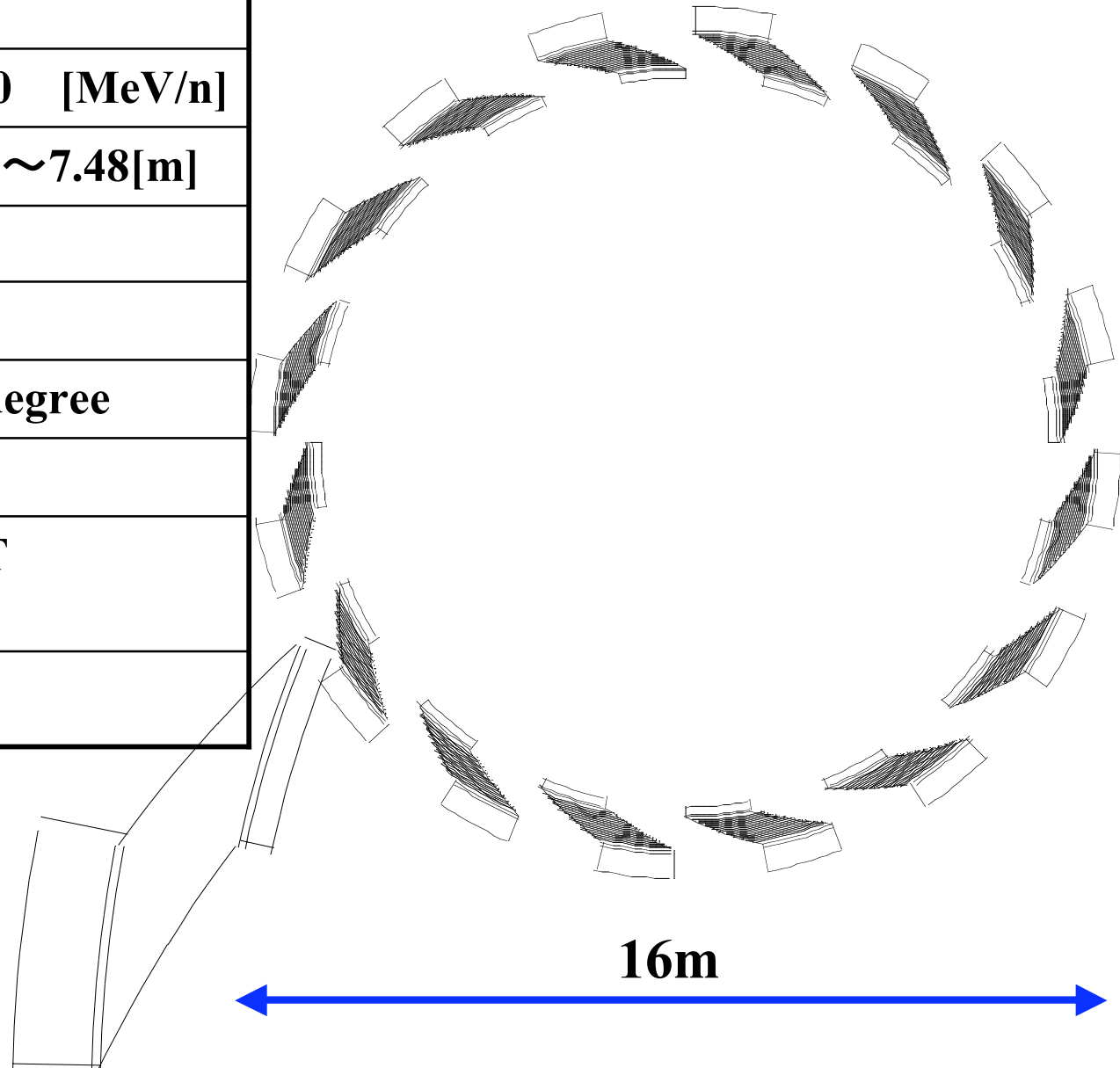

# Superconducting FFAG Accelerator

## Features

- Superconducting bending magnet
- Non-Separated bending magnet
- Untuned RF Cavity
- Quasi - Isochronous magnetic field

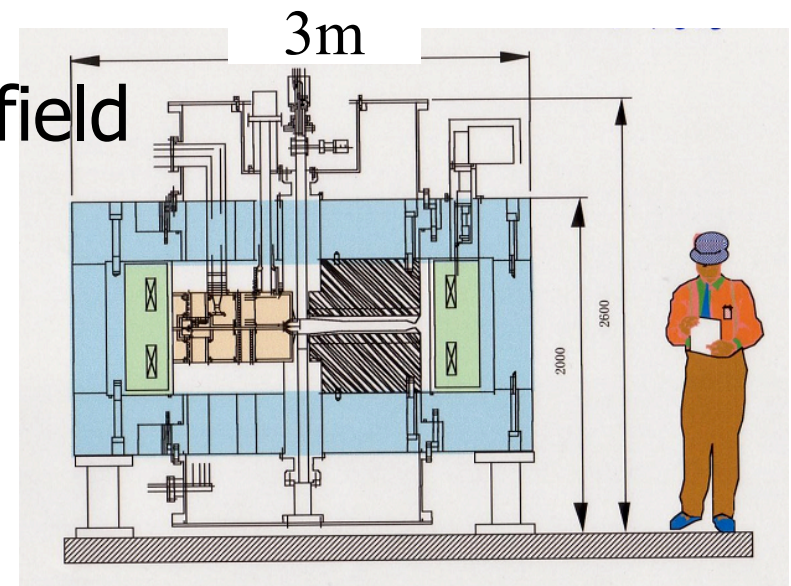

What values difference from an isochronous field ?

- Minimum frequency change  $\sim 1\text{MHz}$
- Large magnetic field error allowed  $\sim 0.1\%$

$$K = 1 - \frac{\frac{dB}{B}}{\frac{dE}{E}} \quad \frac{\Delta\omega}{\omega} = -K \frac{\Delta E}{E}$$

$K=0.1$  is needed.

$$\frac{d^2\varphi}{dt^2} = \frac{eV\omega_s^2 K_s}{2\pi E_s} (\cos\varphi - \cos\varphi_s)$$

Energy	230 MeV (P)
No of Sectors	3
Extraction Radius	700 mm
K value (not FFAG K value)	0.1
RF frequency	43~42 MHz
RF Voltage	10 kV × 6 gap
RF $Q_L$	70 $R_s=4k\ \Omega$
RF Power	12.5kW × 3
Repetition Rate	2 kHz
B field (center)	2.7 T
Magnet Power	46 kW

## Magnetic field

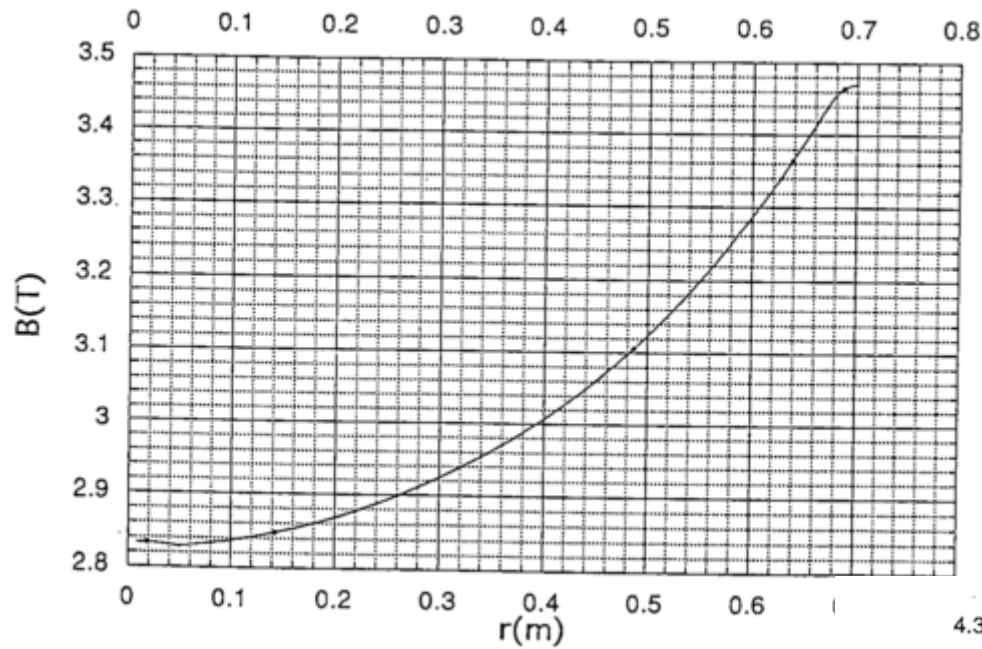

## RF frequency

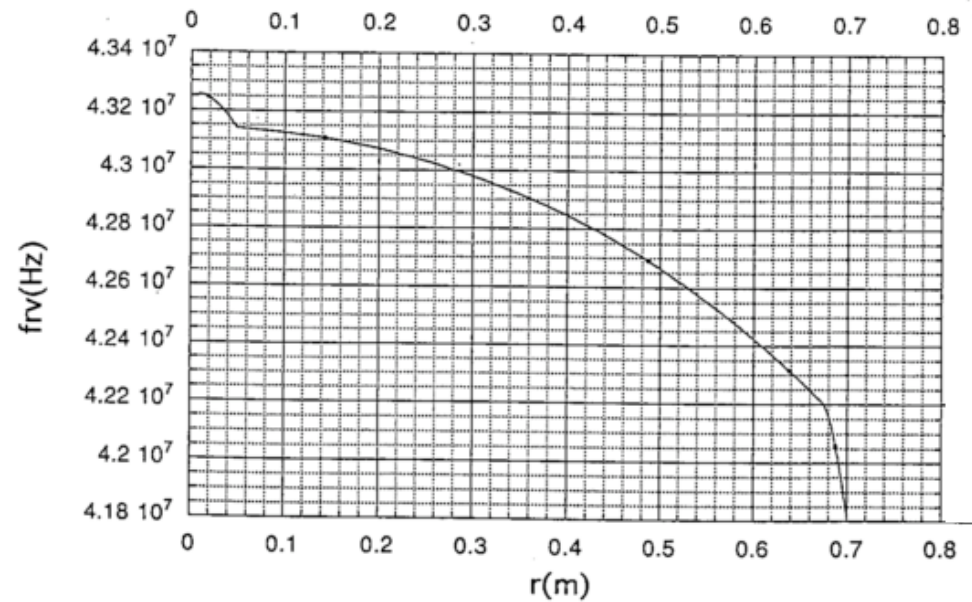

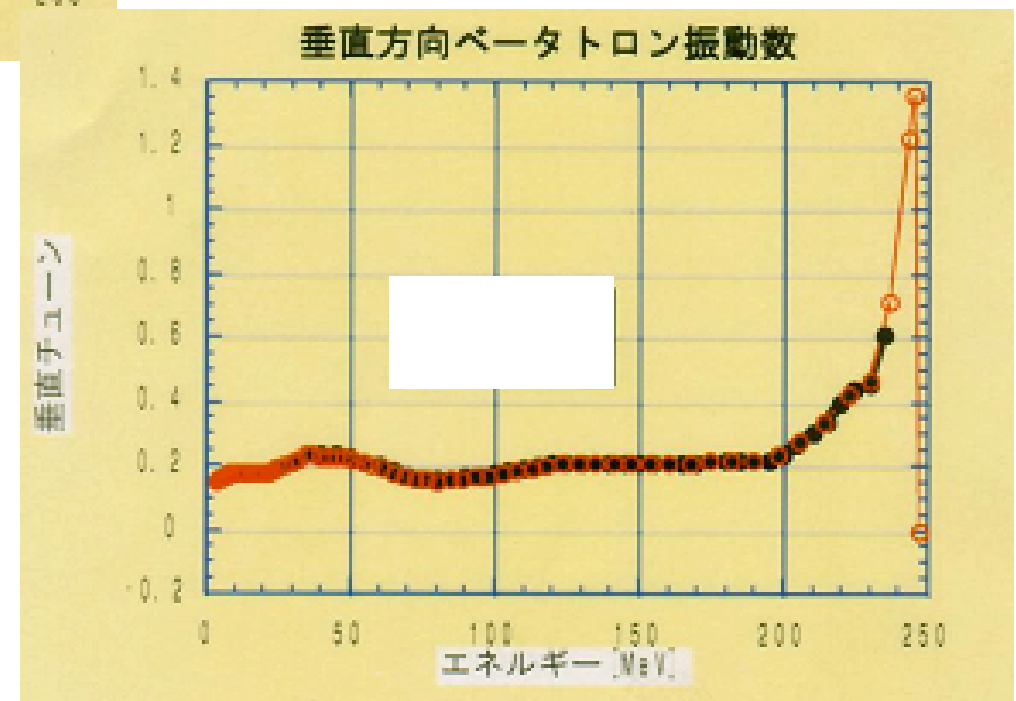
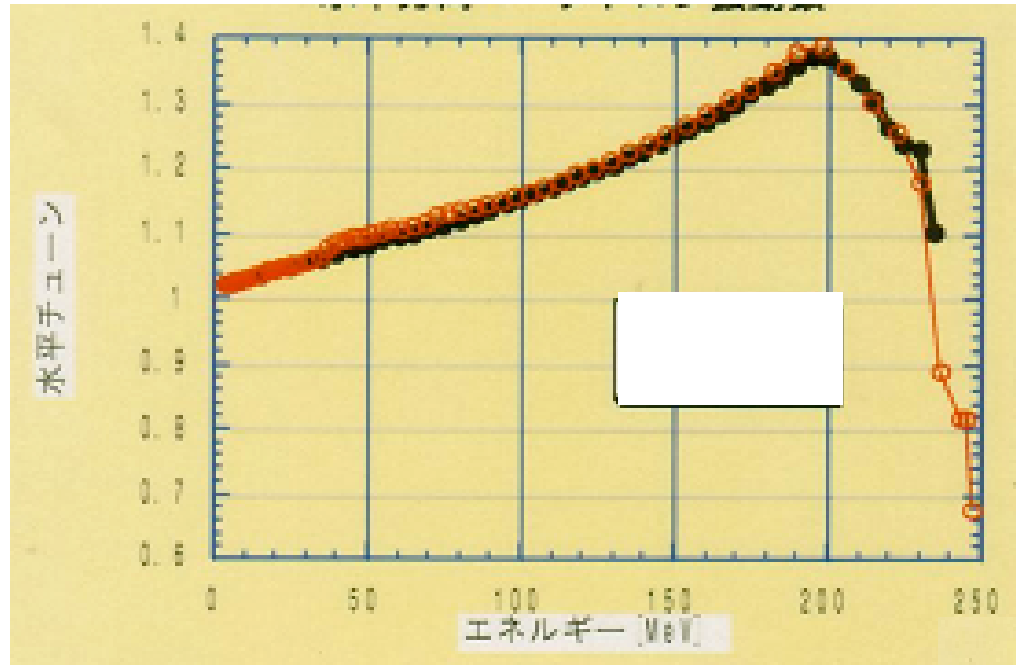

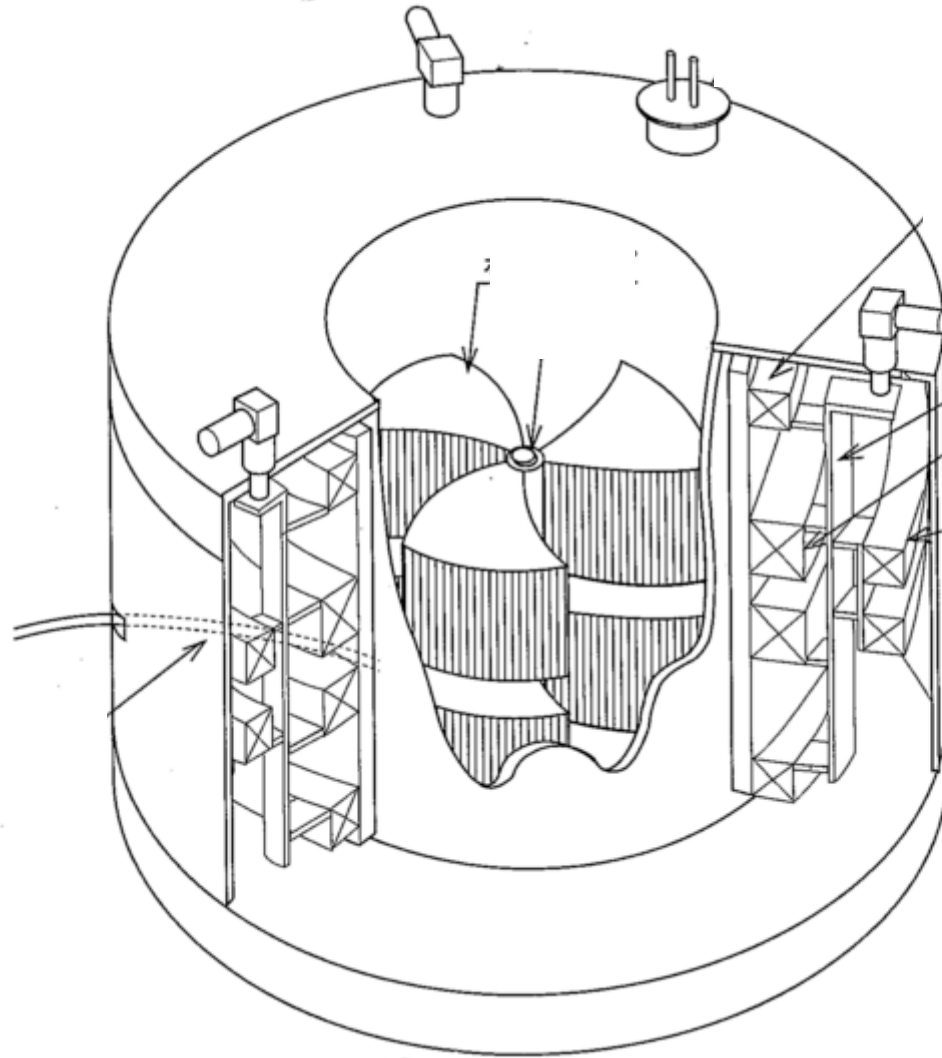

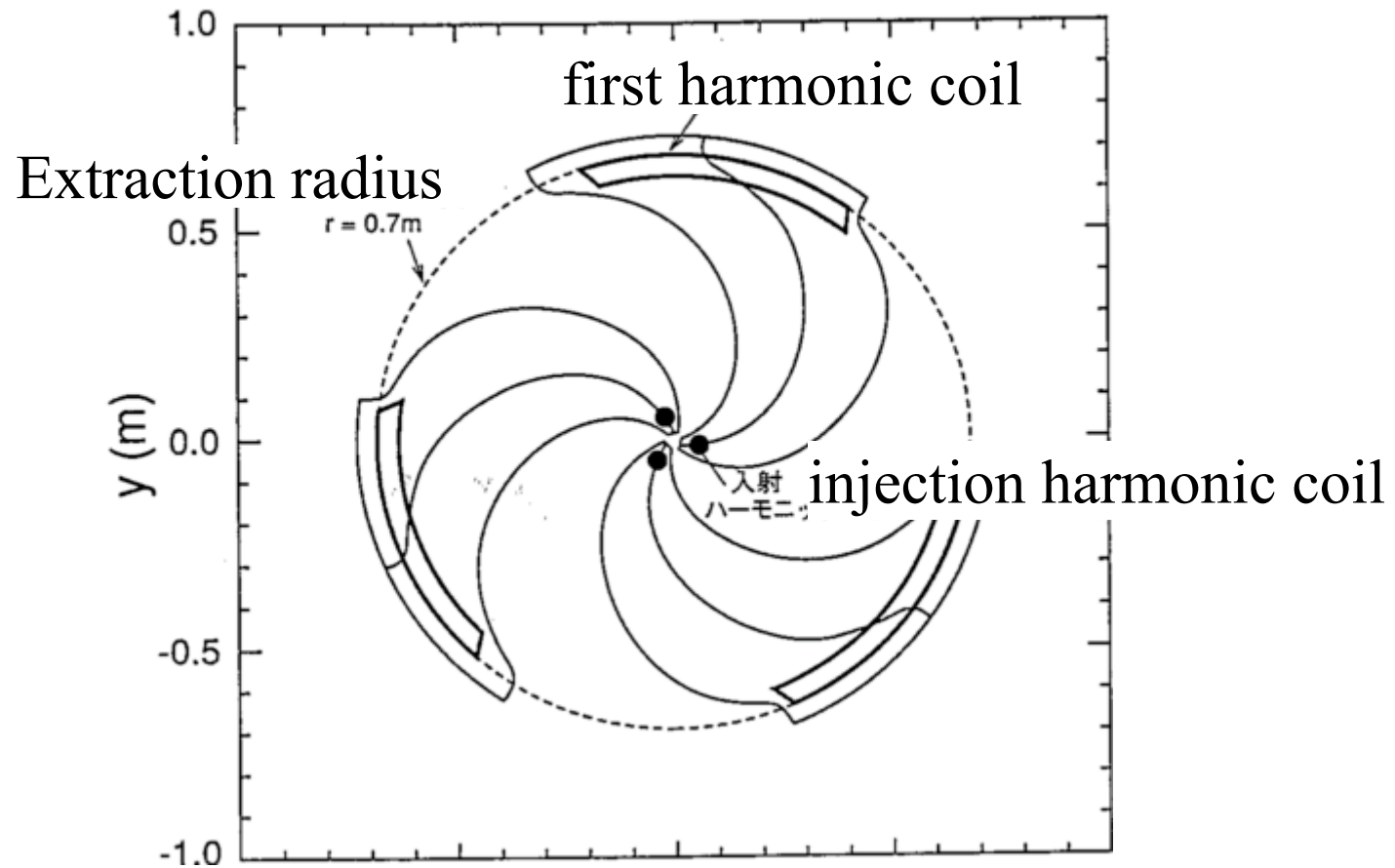

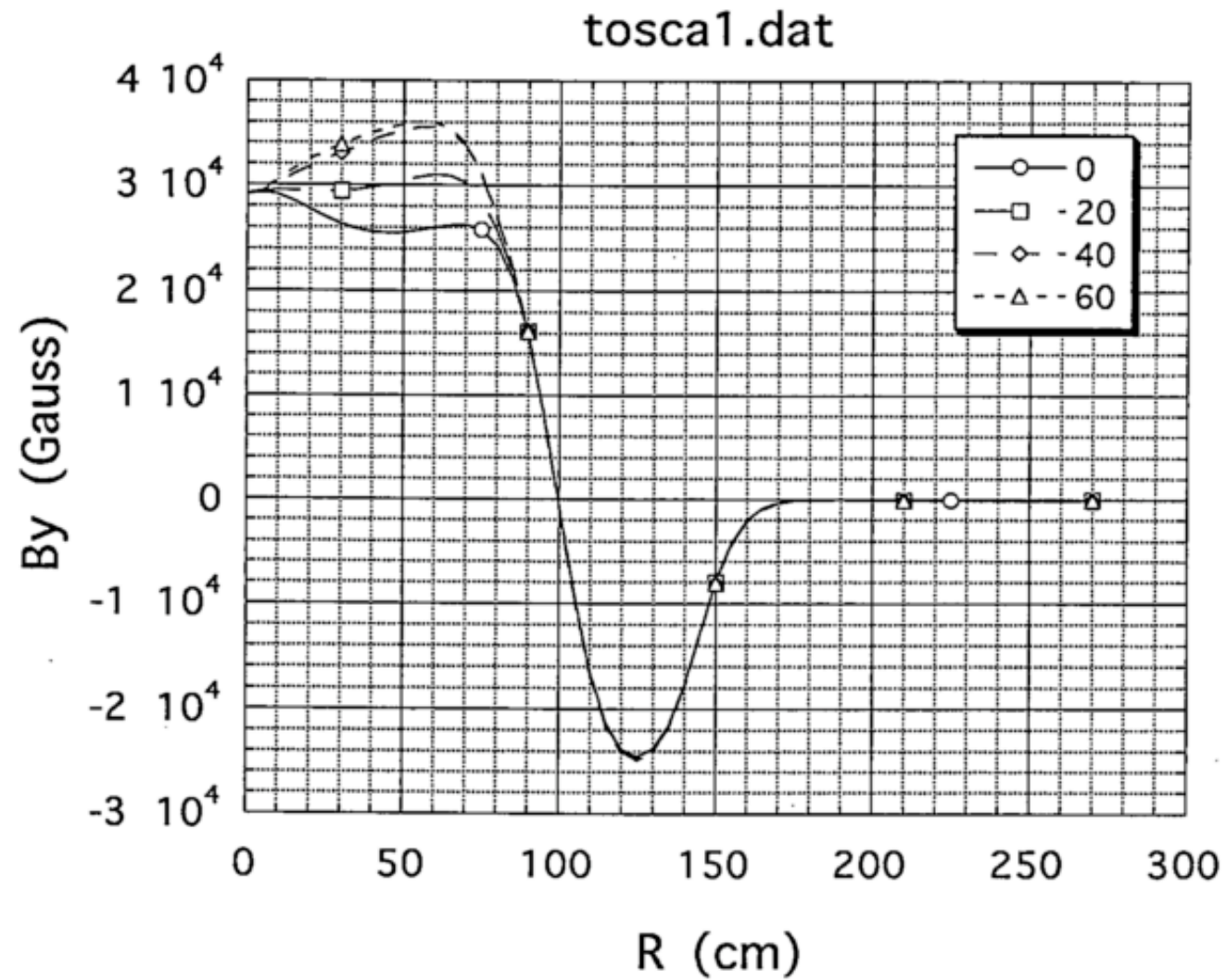

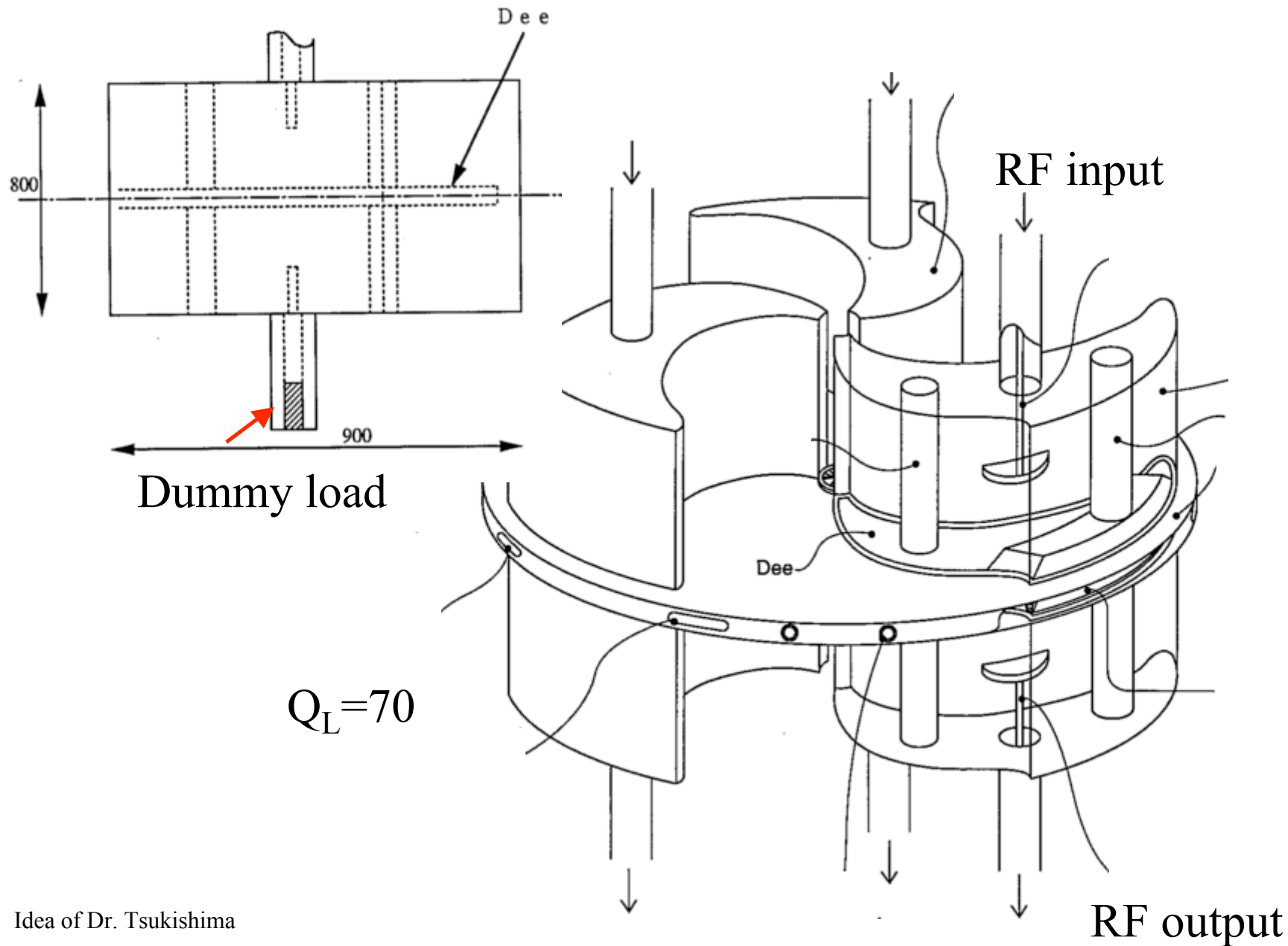

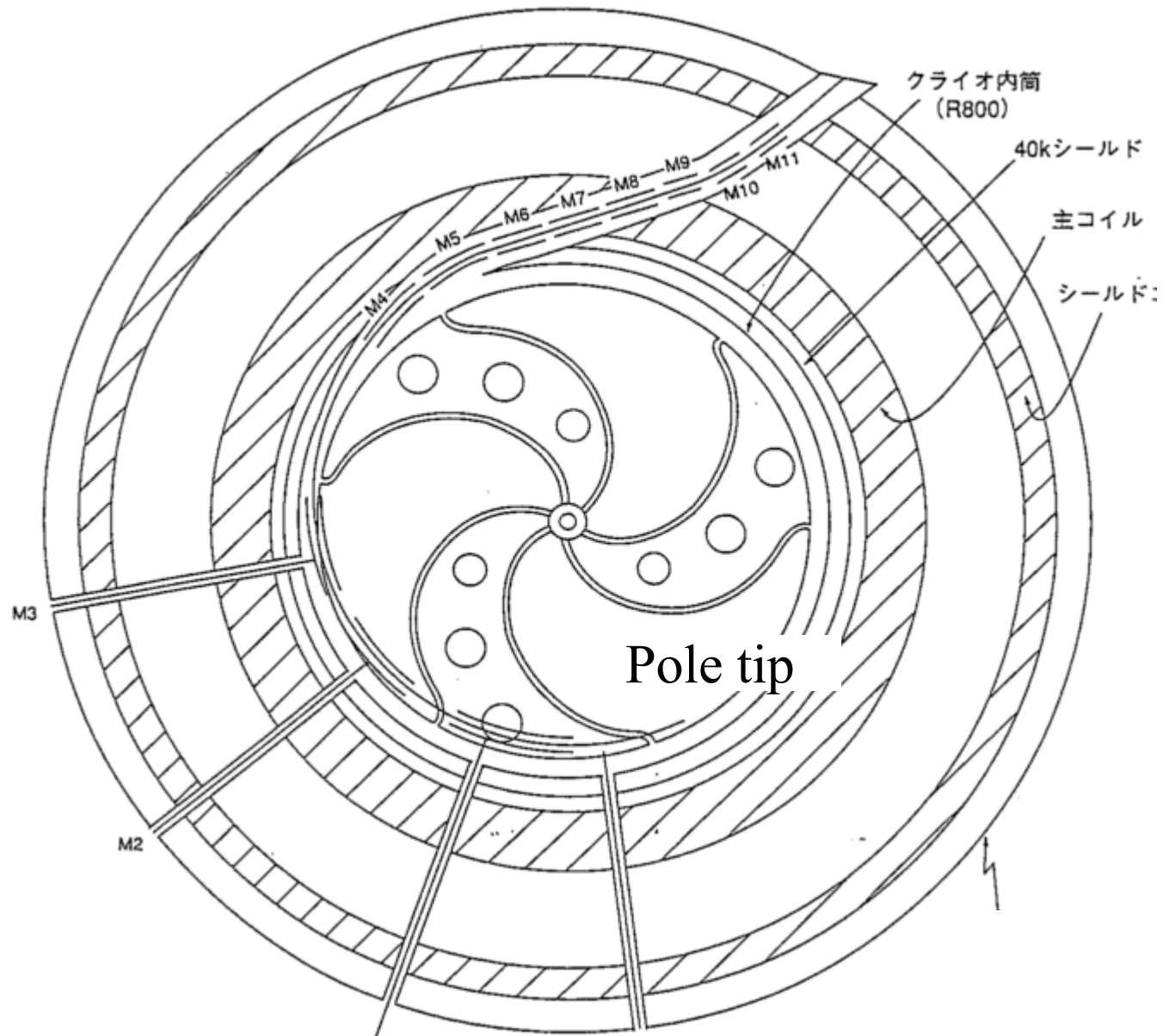

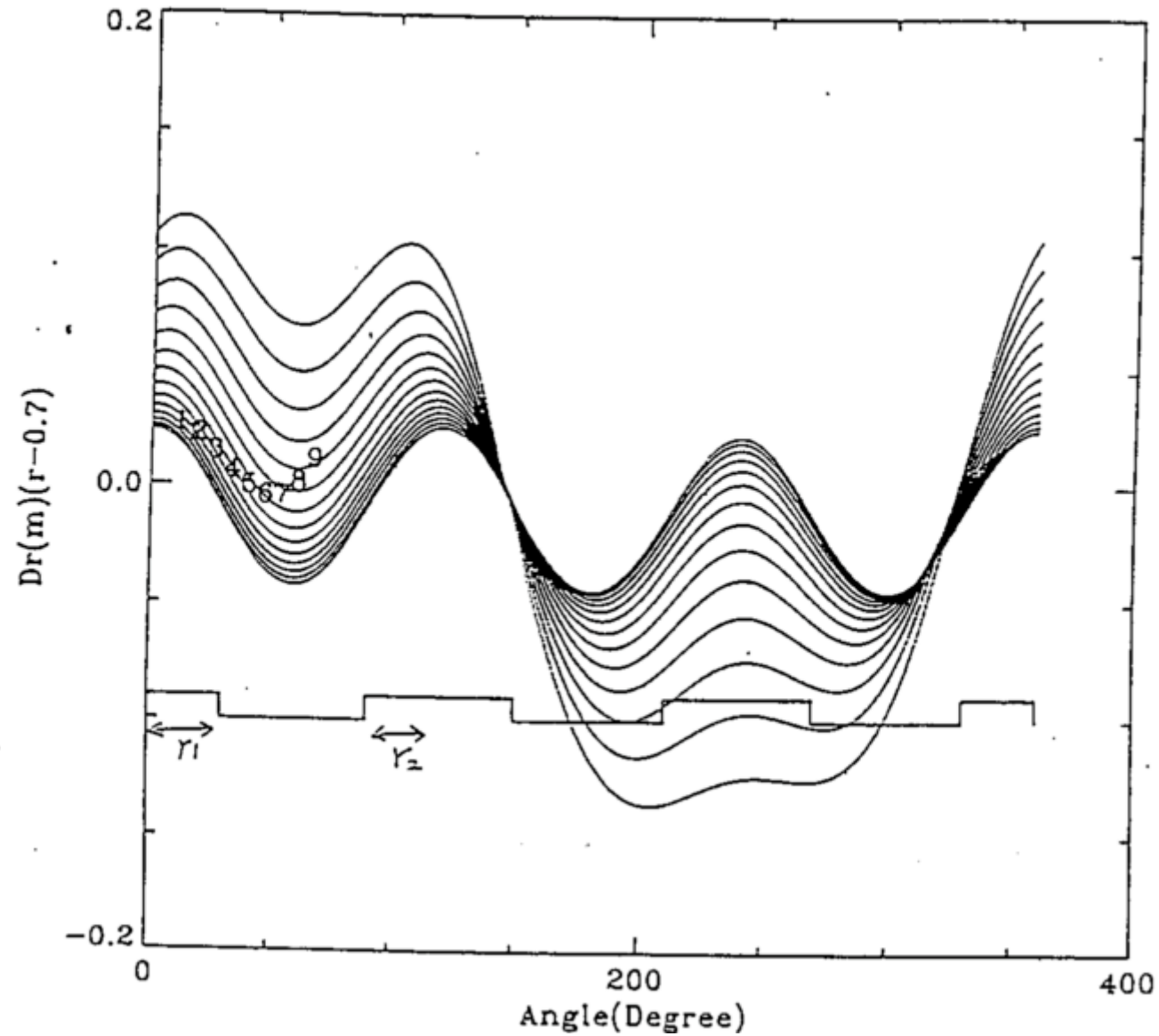

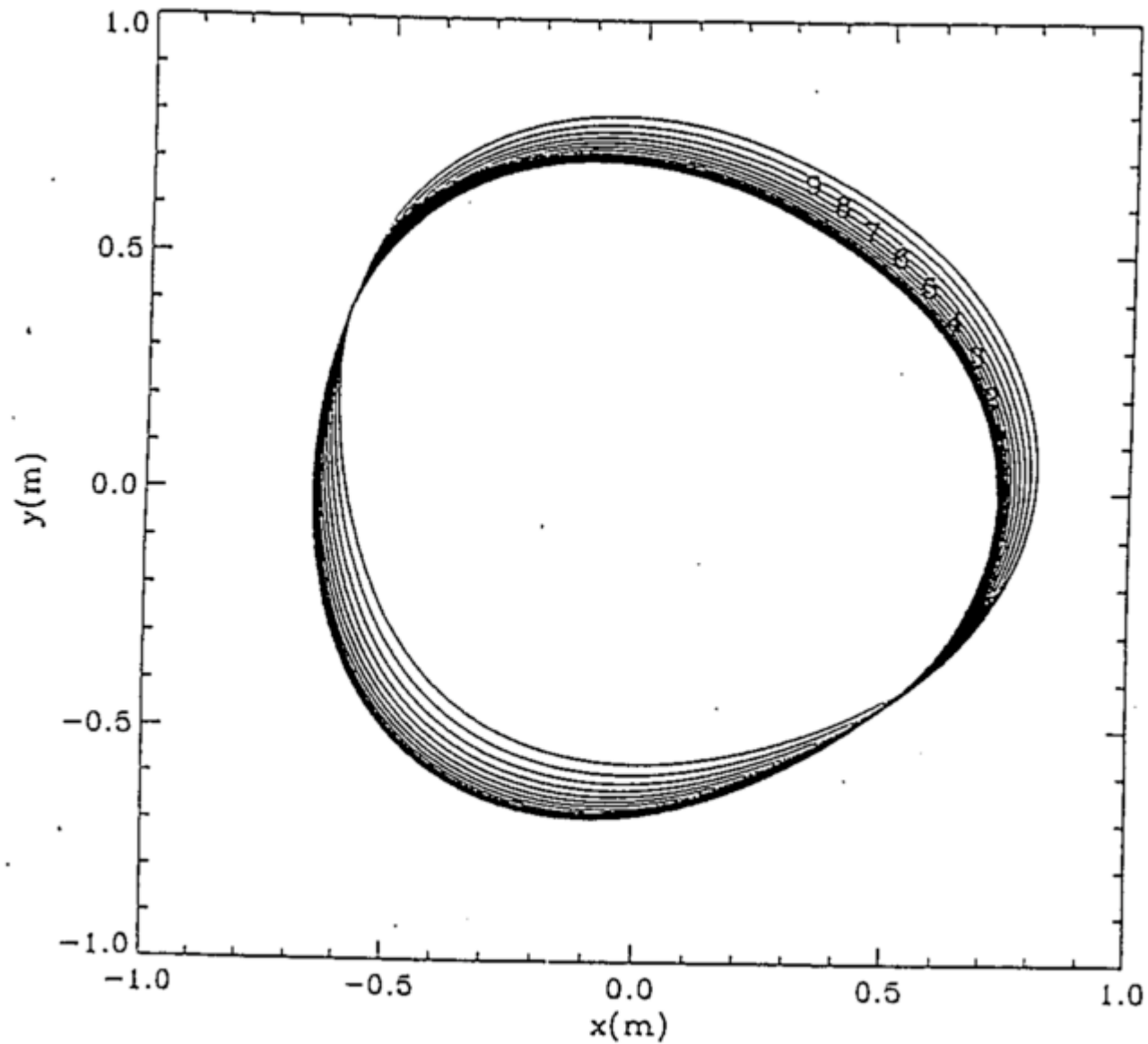

- **Hybrid Accelerator** (Combination between FFAG and Sync.)
  - ◆ Laptop Accelerator : 1 MeV Electron
  - ◆ Injector of a synchrotron: 7 MeV/n C4+
  - ◆ Main ring: 400 MeV/n C6+
- **Superconducting FFAG Accelerator**
  - ◆ 230 MeV P
- **FFAG and quasi-FFAG accelerator can be used for many industrial and medical fields.**