

Development of PRISM-FFAG Magnet

Yasushi Arimoto, Osaka University

FFAG05 @KURRI

Contents

- Introduction
- Engineering design and effect of machining error
- Trim coil
- Conclusion

Lattice Parameters

- Radial sector DFD triplet
- Number of cells : 10
- k value : 4.6
- F / D ratio : 6.0
- Momentum : $68 \text{ MeV} / c \pm 20 \%$
- Average radius : 6.5 m

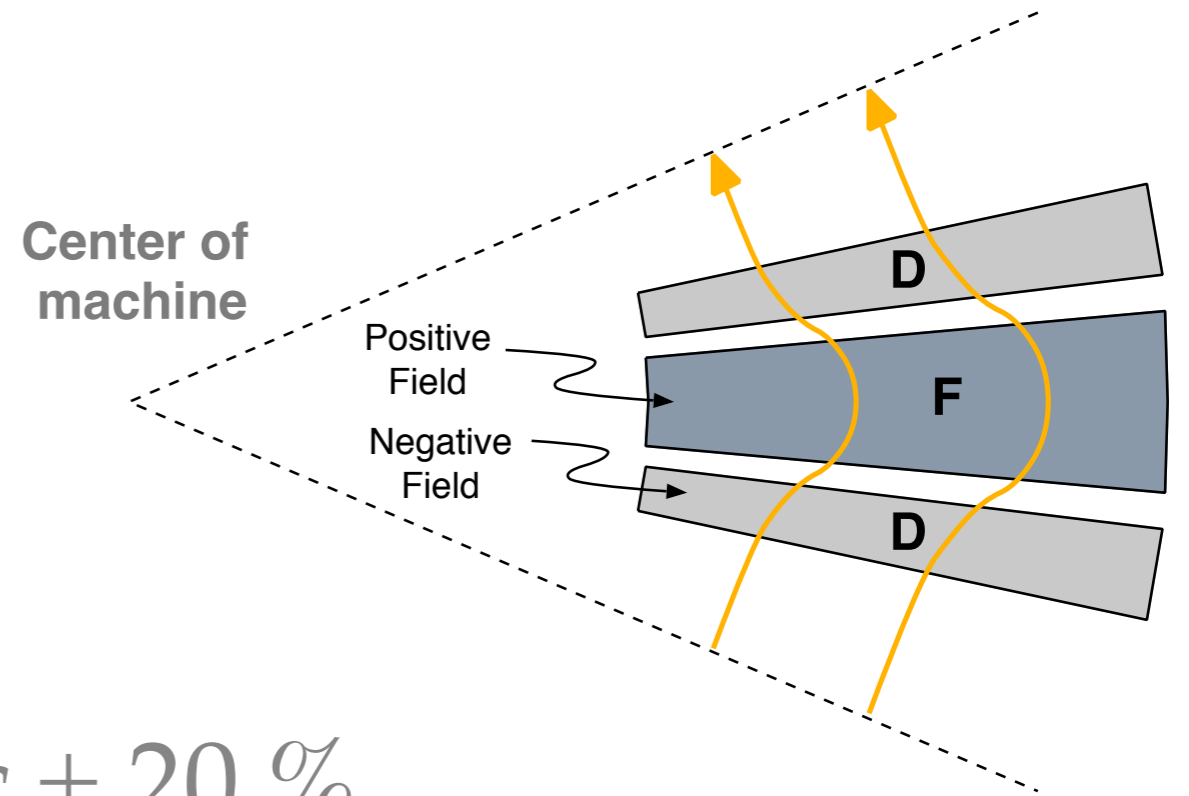

Magnet form

- Radial sector DFD triplet
- C type
- Aperture
 - 100 cm (horizontal)
 - 30 cm (vertical)
- Slant pole produce field gradient
- Trim coils

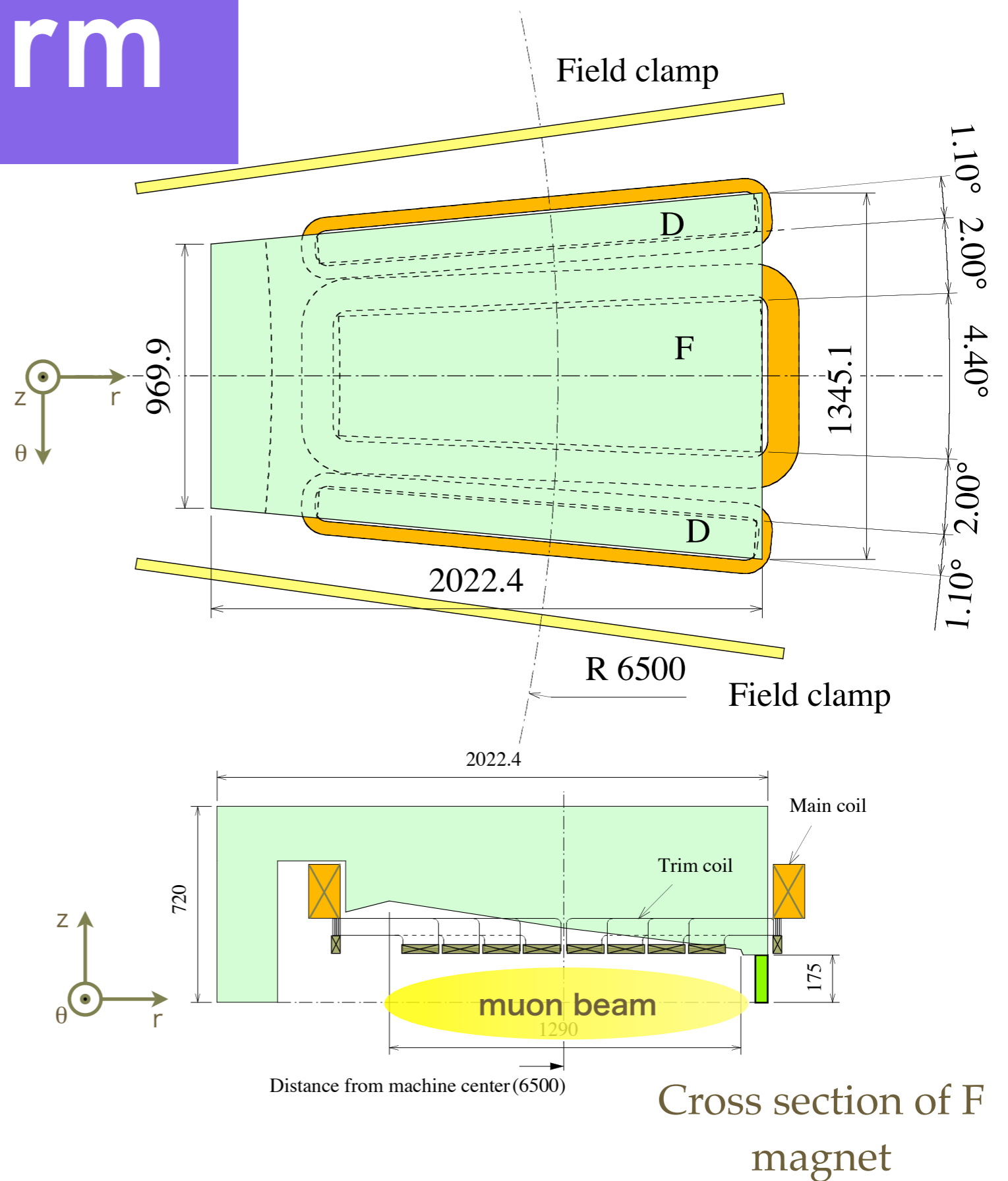

Calculated Field

TOSCA calculation

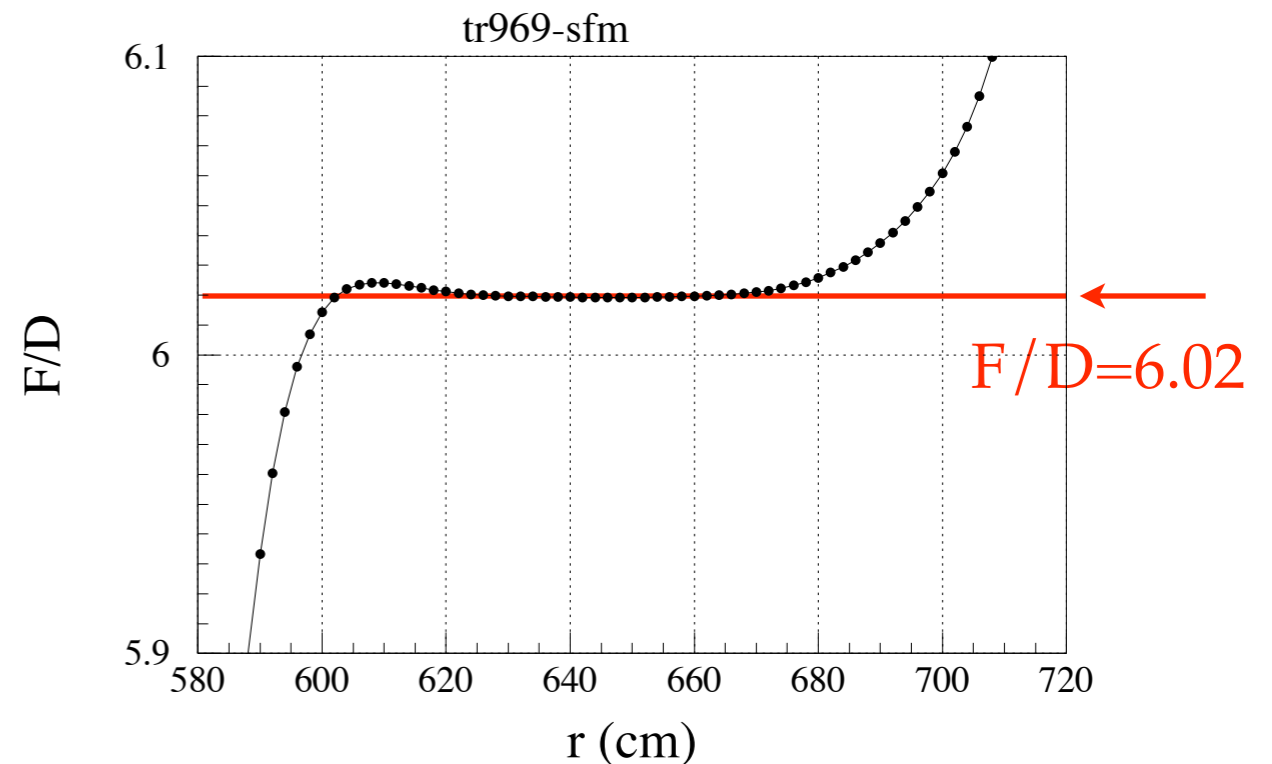
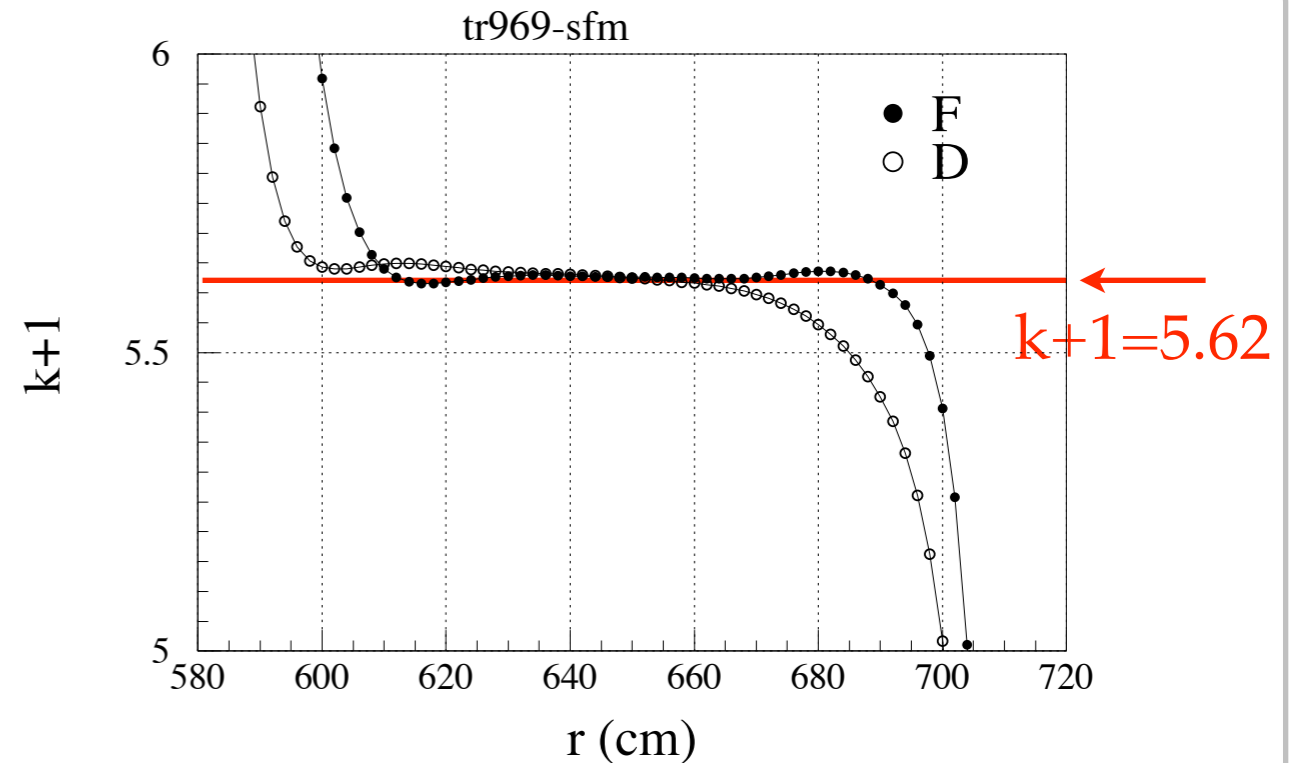
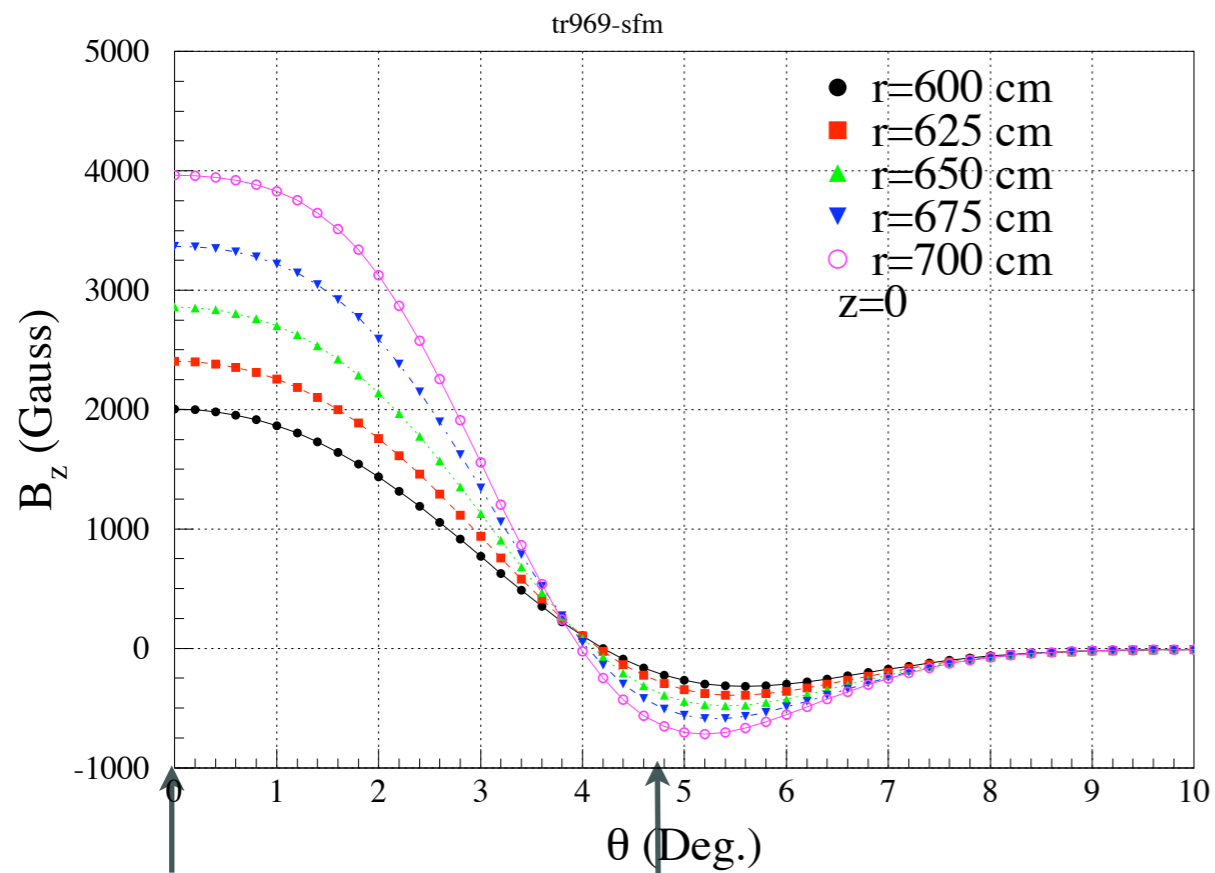

4D Acceptance

- Momentum vs 4D Acceptance

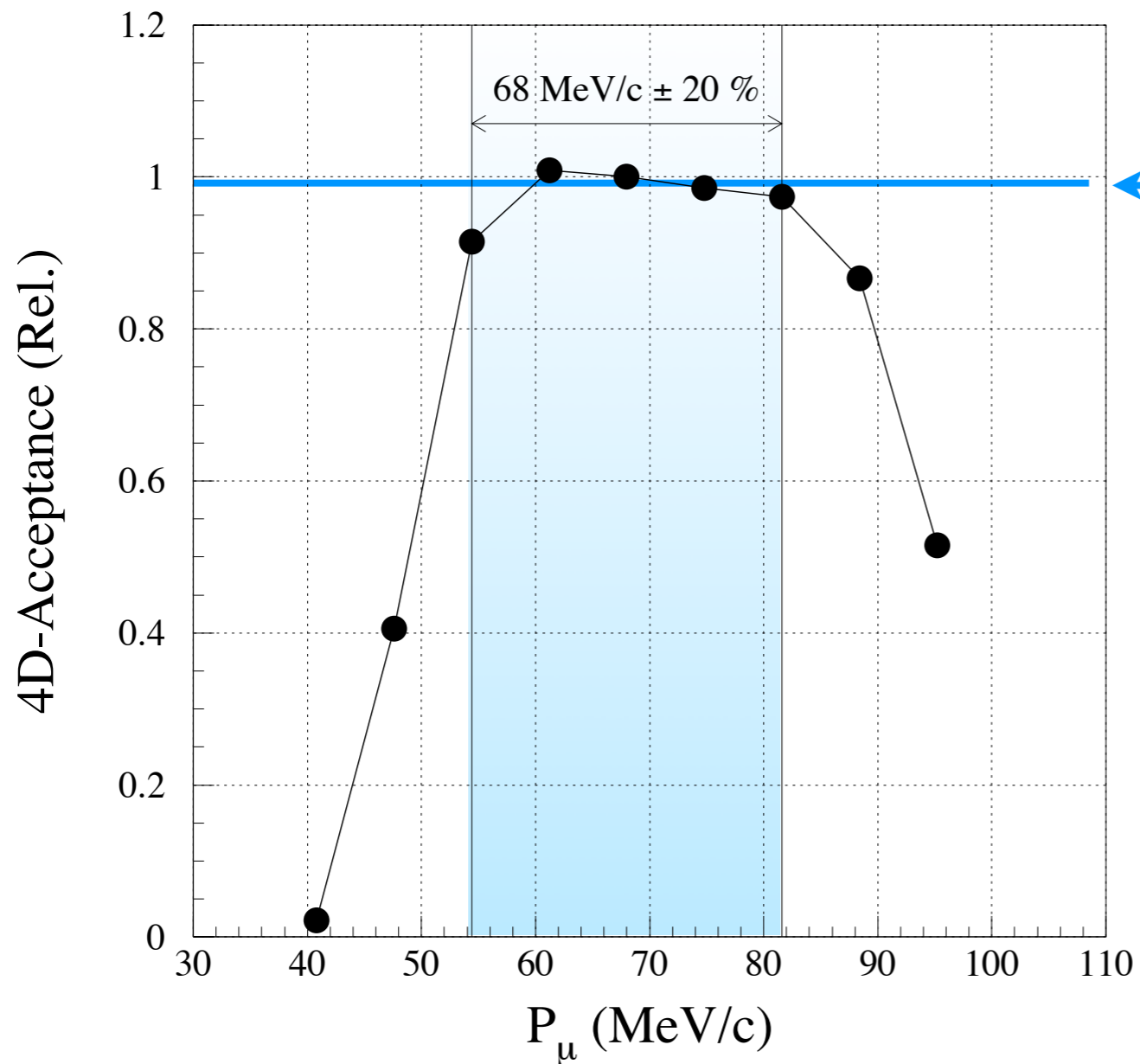

← 590×10^6 (mm mrad)²

Momentum acceptance
of $\pm 20\%$ has been
achieved !

Yoke structure

- Yoke consists of 6 constructional member.
- This configuration provides good cost performance because the magnet is able to produce from iron plates.

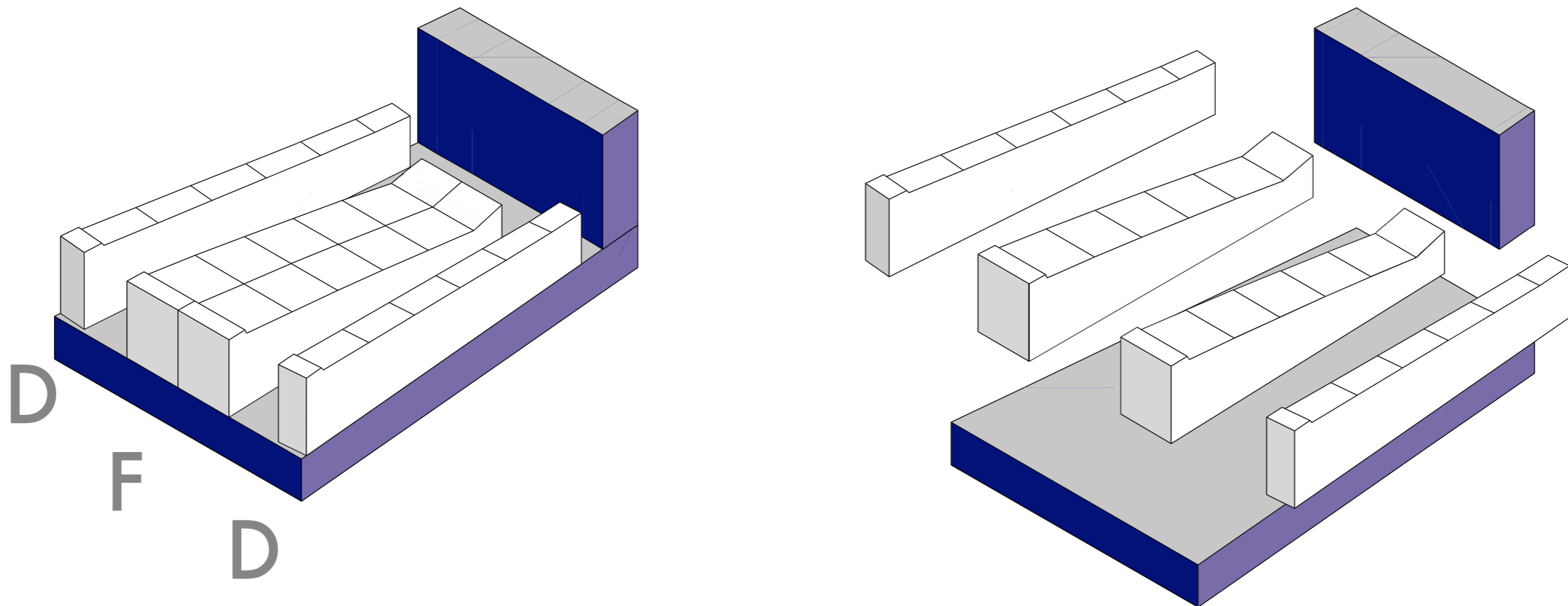

Yoke structure

- Yoke consists of 6 constructional member.
- This configuration provides good cost performance because the magnet is able to produce from iron plates.
- But, this configuration make a thin air gap at the connected positions. These increase a magnetic resistance and these become a source of individual difference of magnets.

4D acceptance

- Tracking simulation has been performed including individual difference of magnets.

Map set : 3 different map

#1 : I_D offset = 0 (Ref.)
#2 : I_D offset = +R %
#3 : I_D offset = -R %

I_D : Current of D coils

Acceptable error of BL_D is less than ± 0.7 %.

± 0.7 %

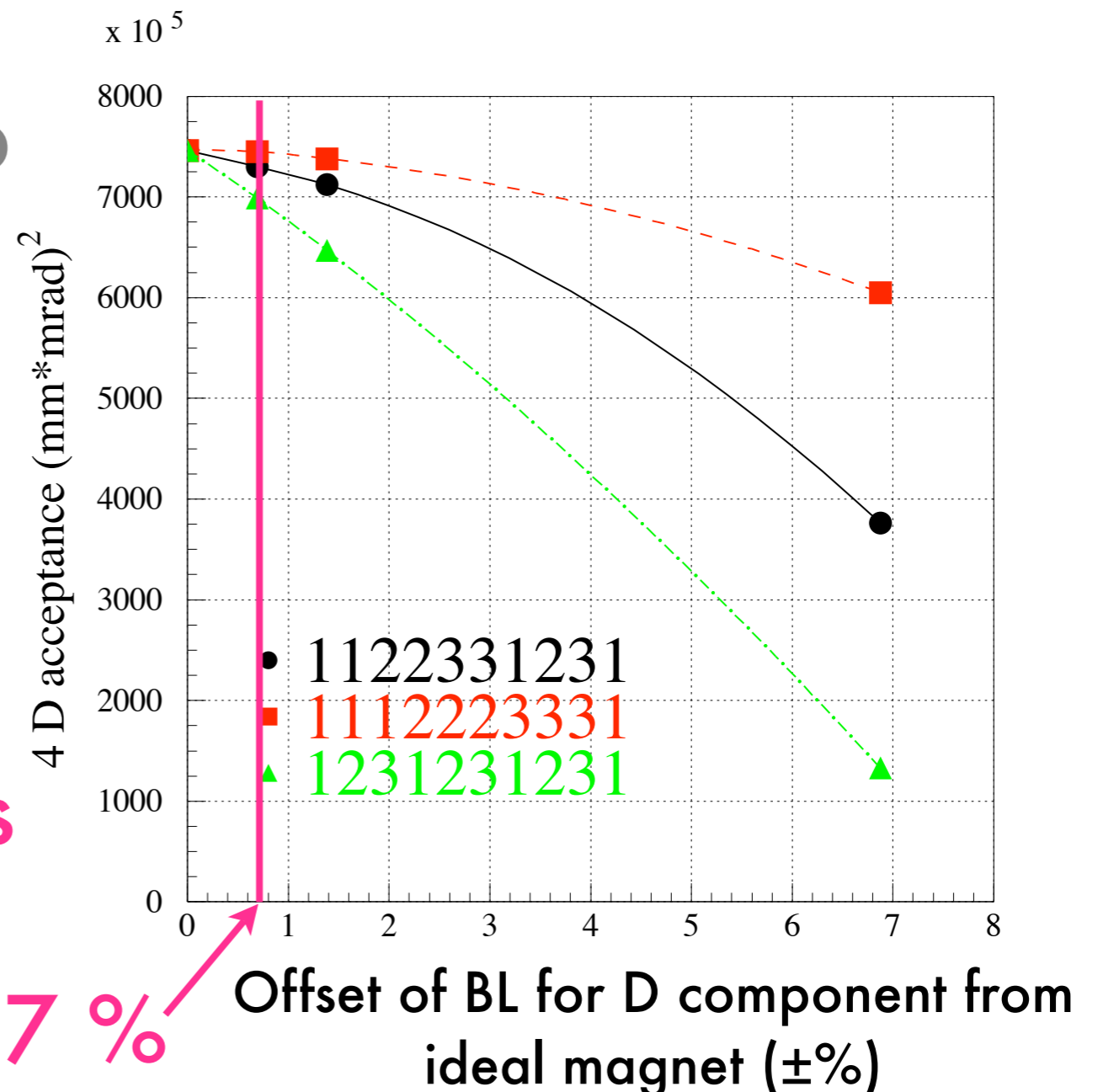

Field deviation from ideal magnet

- TOSCA calculation are performed by inserting air layer at connected position.

tosca/0412/07/comp-stp-srtrn.kumac

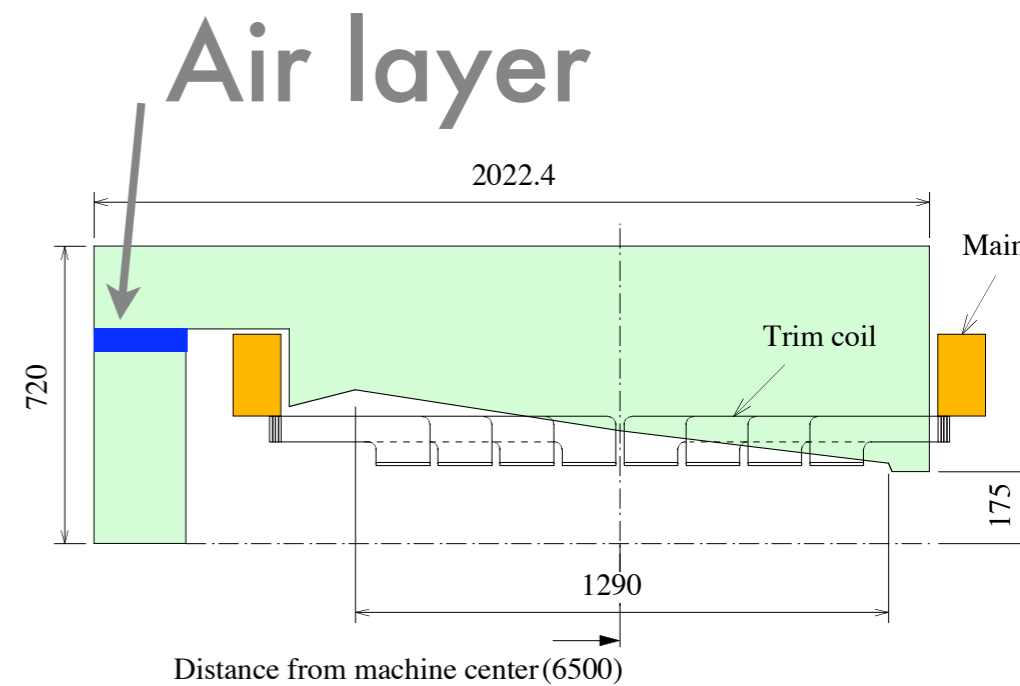
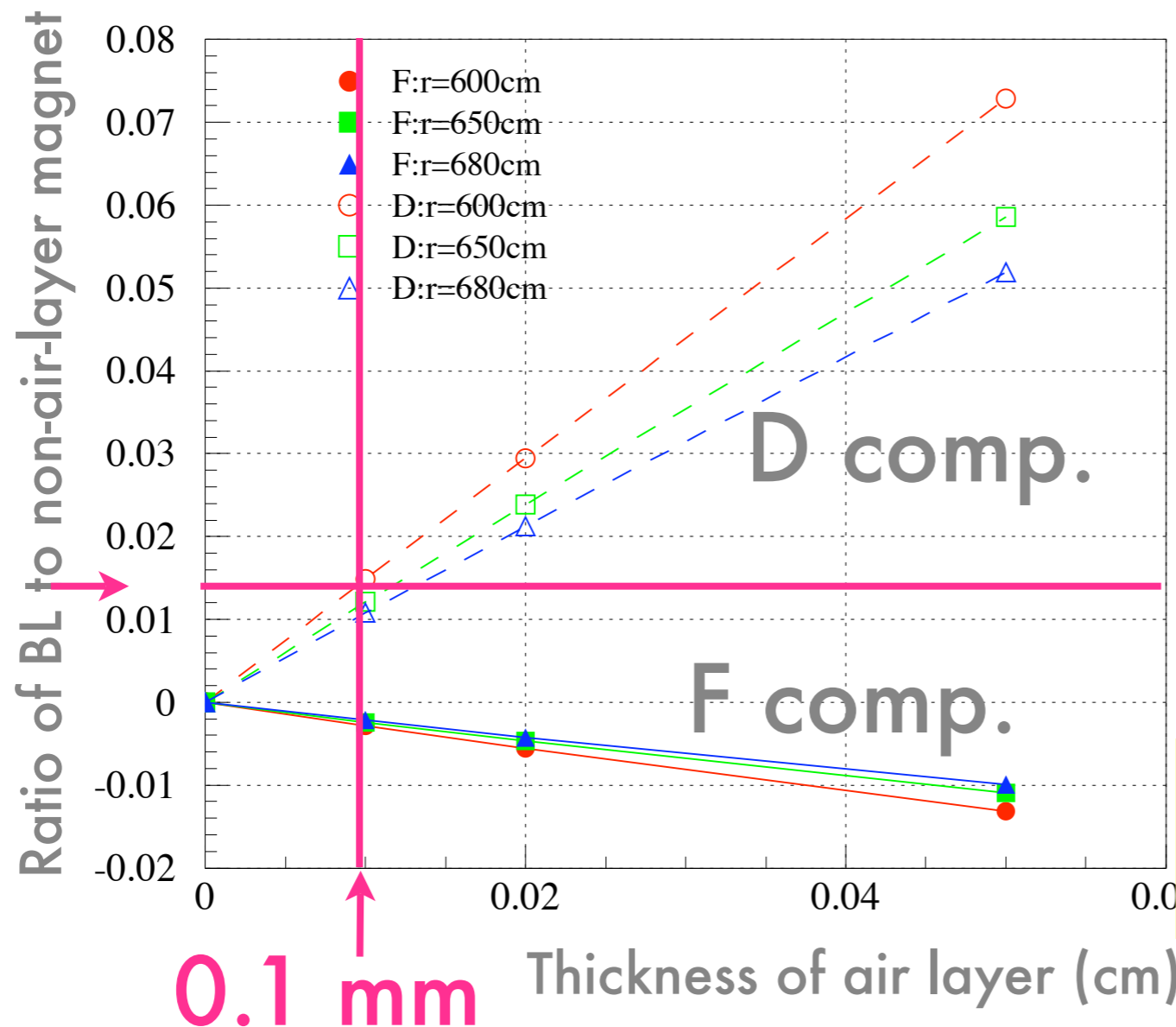

The layer thickness of 0.1 mm is acceptable.

4D acceptance variation due to BH curve difference

BH Curve

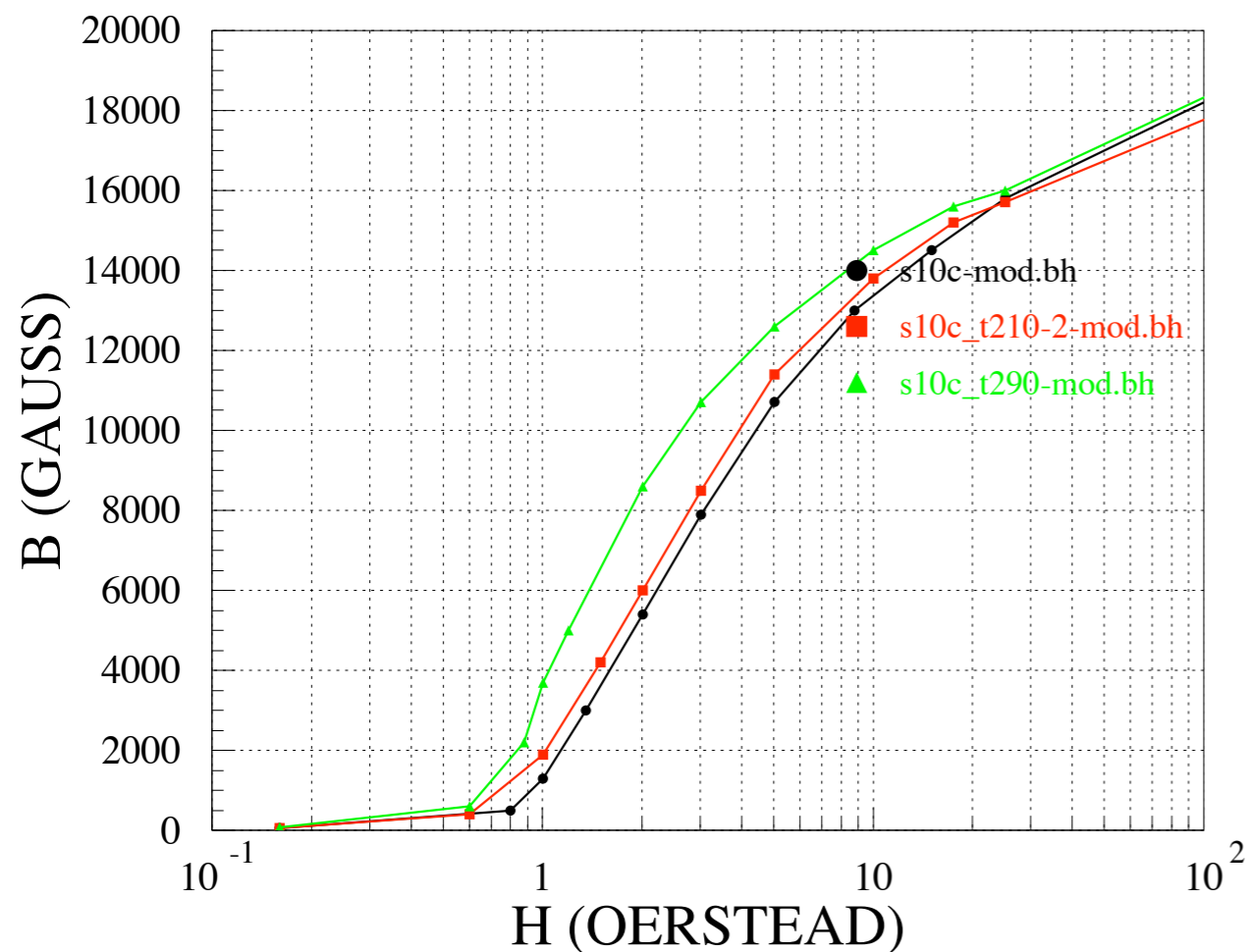

μ -H Curve

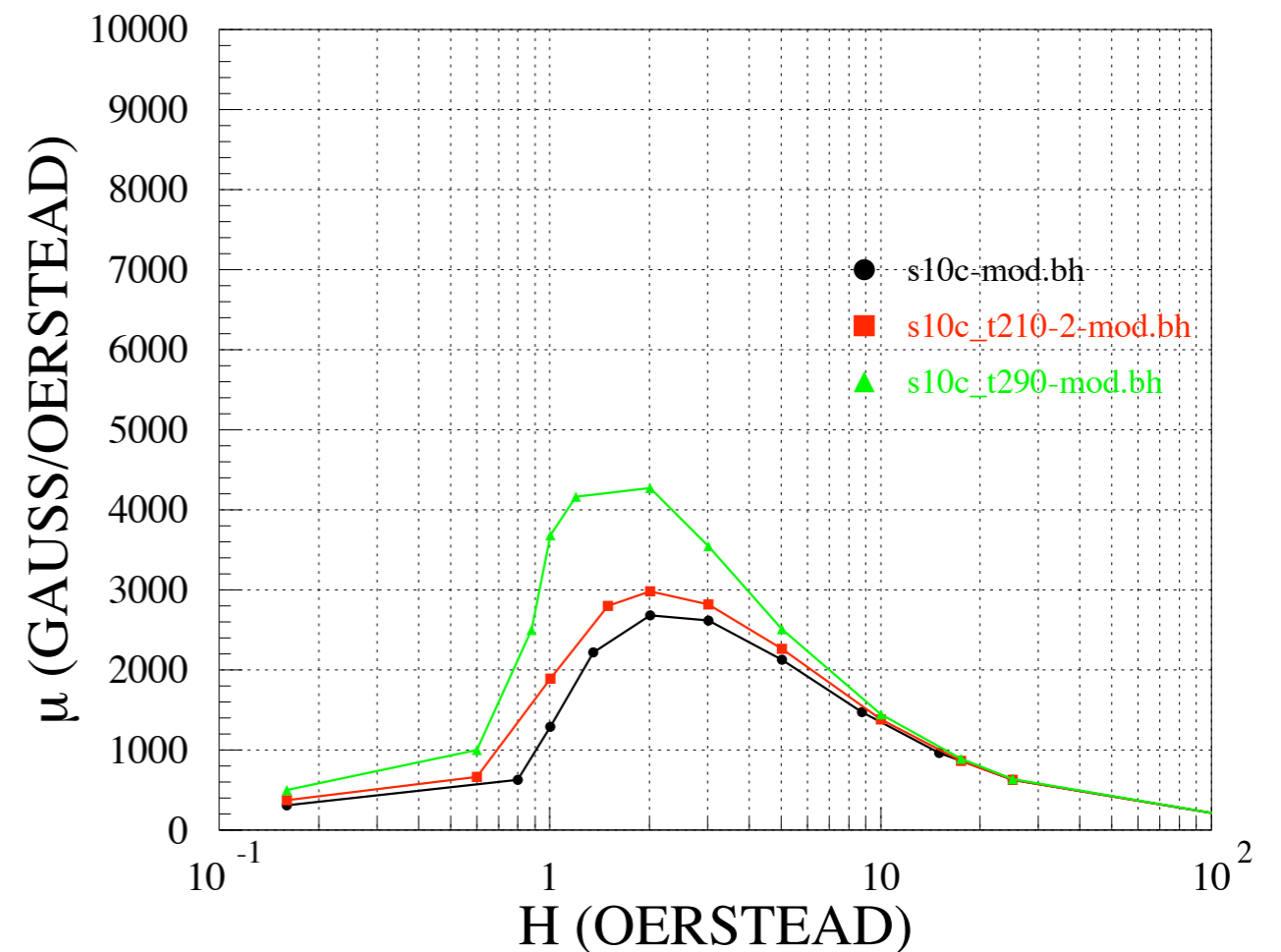

Field variation due to BH curve difference

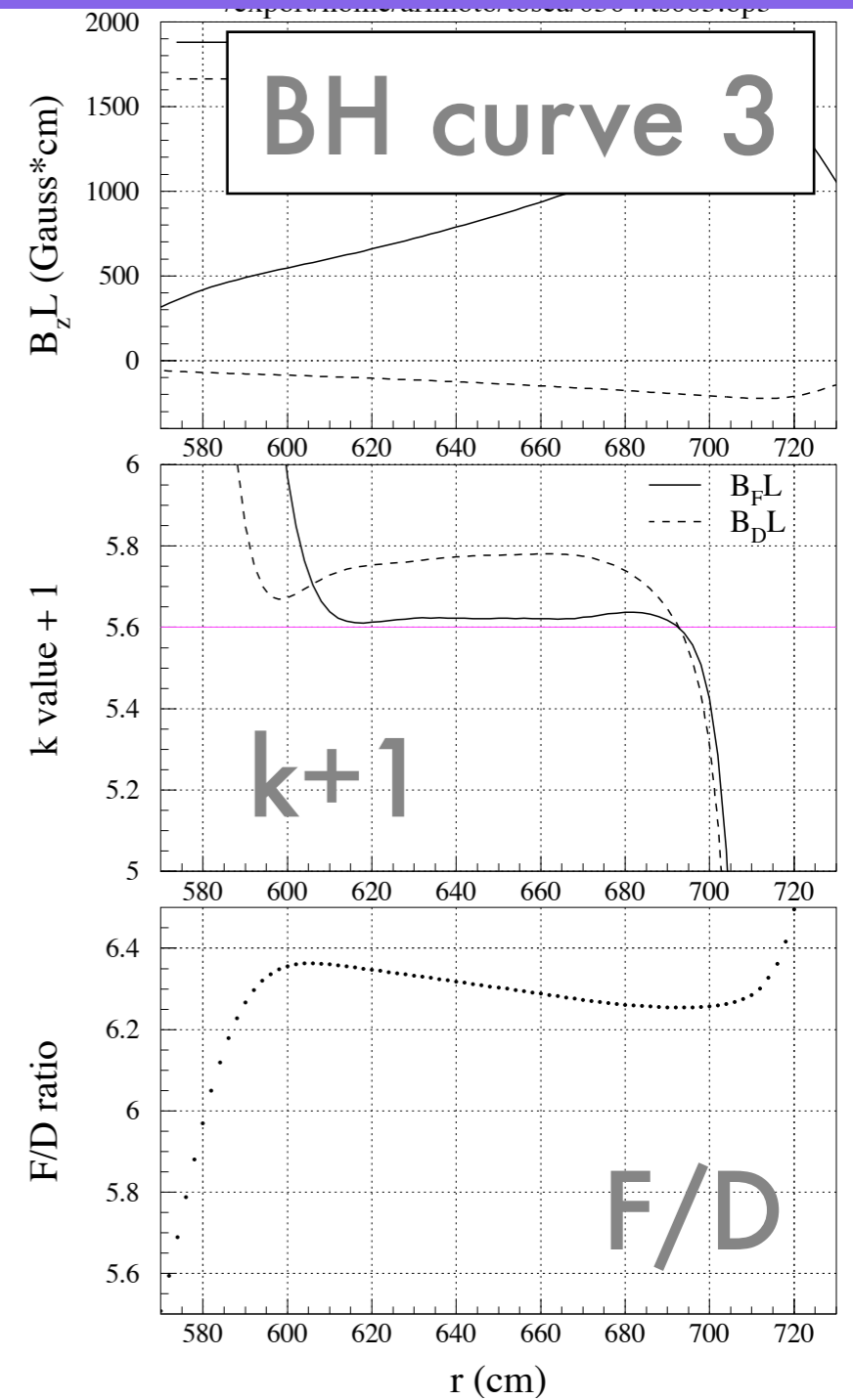
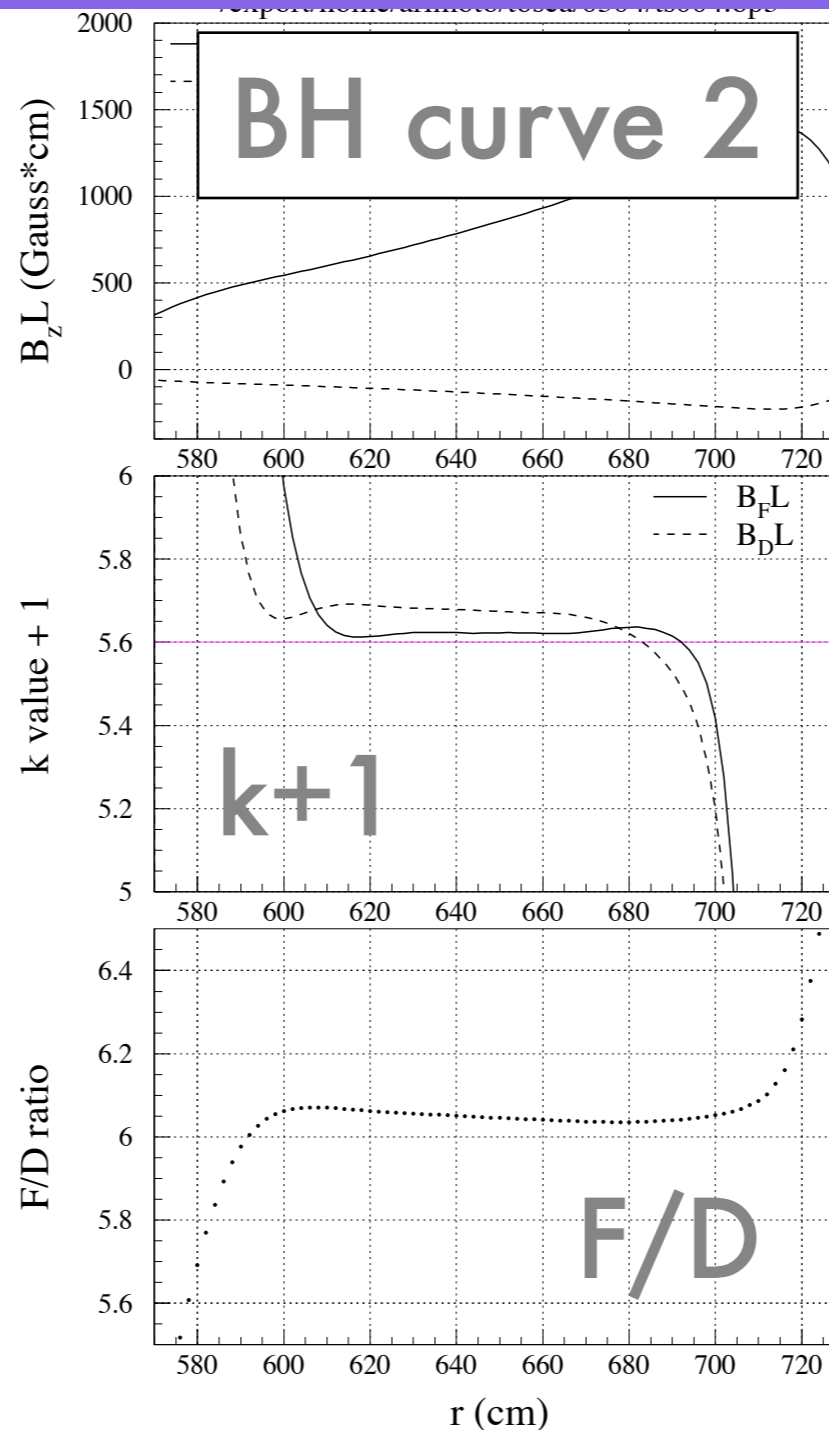
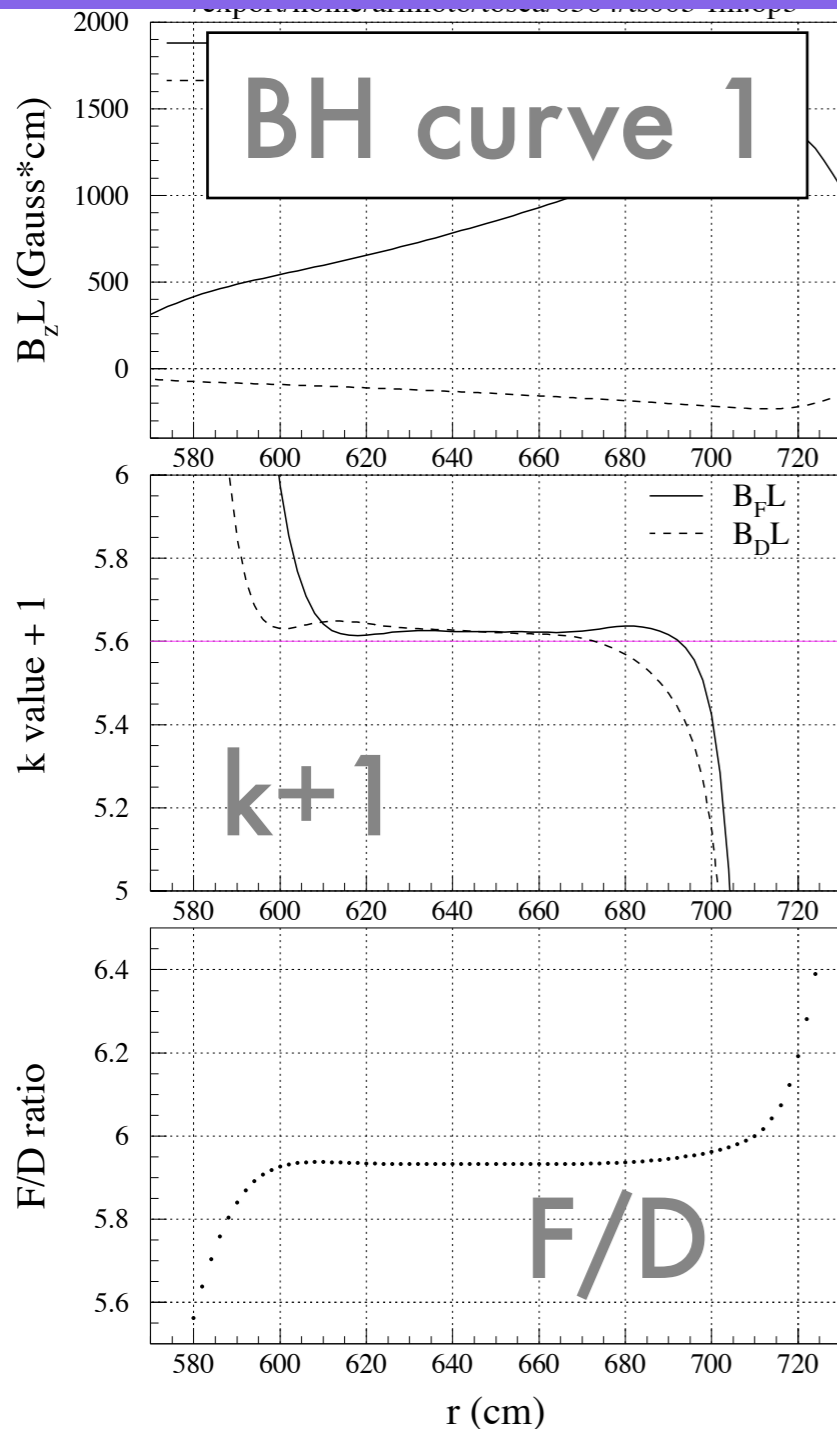

4D acceptance of ring consist of different BH property magnets

- Even if there is individual difference in each magnet, we can obtain 4 D acceptance same as ideal ring (no individual difference) by shuffling.

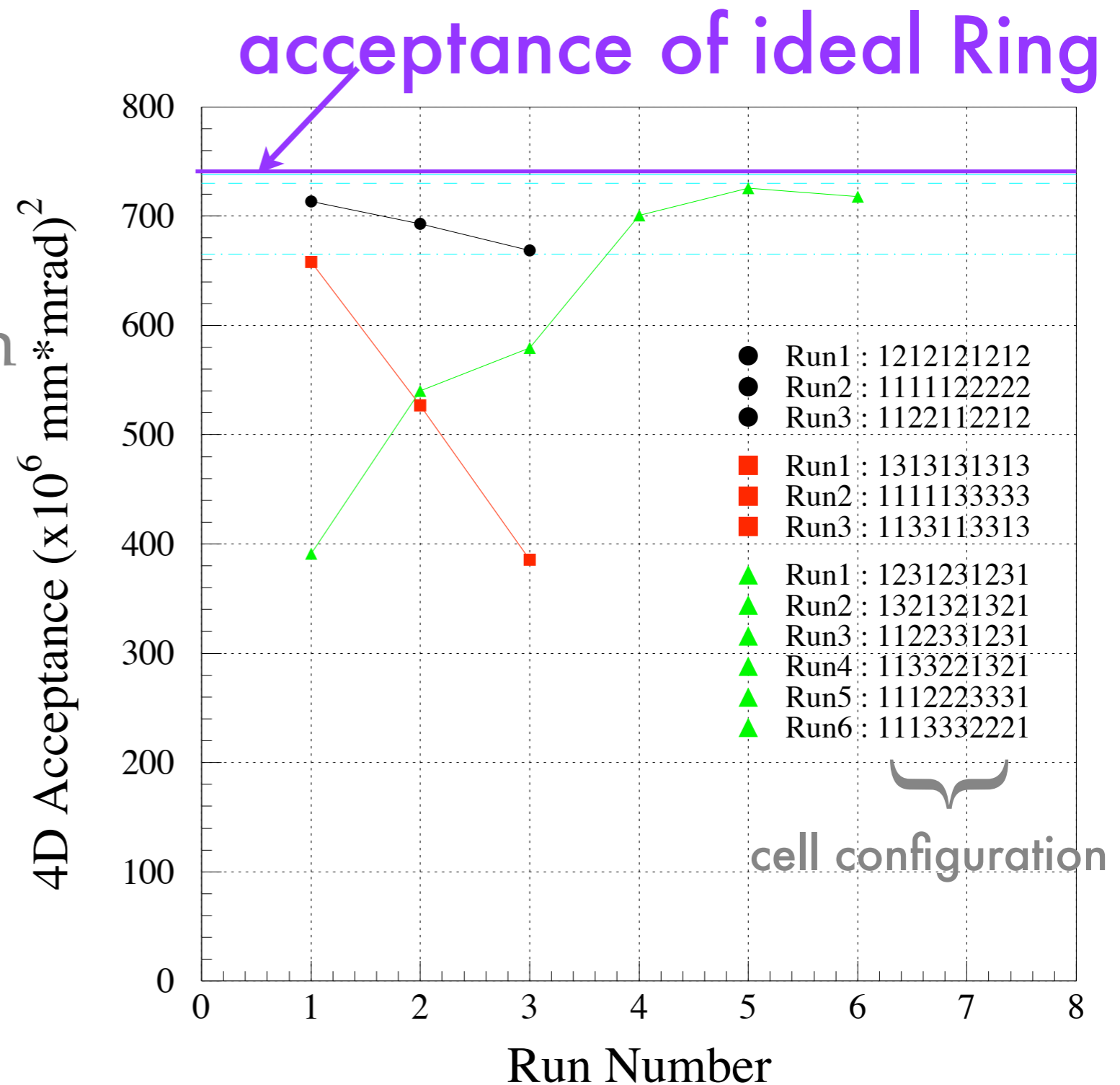

Magnetic Field in RF Core

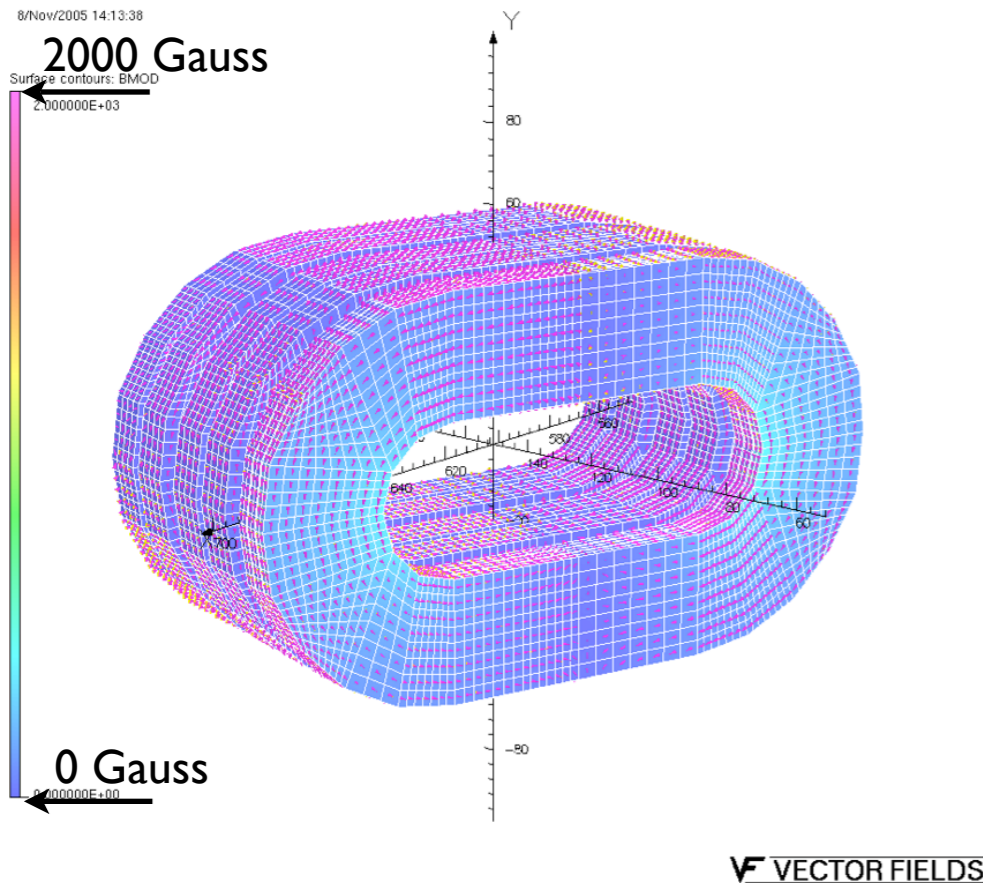

UNITS	
Length	cm
Magn Flux Density	gauss
Magn Field	oersted
Magn Scalar Pot	oersted-cm
Magn Vector Pot	gauss-cm
Elec Flux Density	C/cm ²
Elec Field	V/cm
Conductivity	S/cm
Current Density	A/cm ²
Power	W
Force	N
Energy	J

PROBLEM DATA	
ts096.op3	TOSCA Magnetostatic
	Non-linear materials
	Simulation No 1 of 1
	212160 elements
	223491 nodes
	30 conductors
	Nodally interpolated fields

Local Coordinates	
Origin: 0.0, 0.0, 0.0	
Local XYZ = Global XYZ	

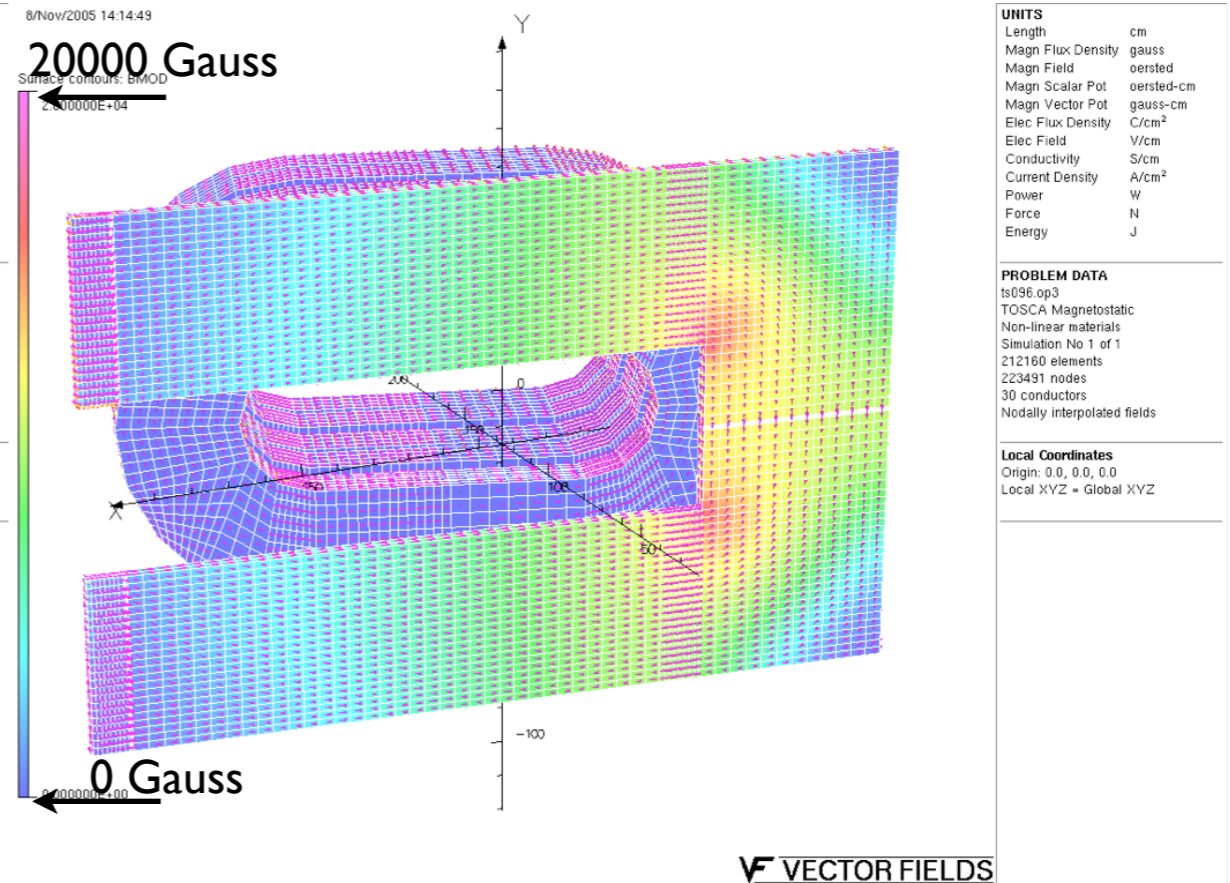

UNITS	
Length	cm
Magn Flux Density	gauss
Magn Field	oersted
Magn Scalar Pot	oersted-cm
Magn Vector Pot	gauss-cm
Elec Flux Density	C/cm ²
Elec Field	V/cm
Conductivity	S/cm
Current Density	A/cm ²
Power	W
Force	N
Energy	J

PROBLEM DATA	
ts096.op3	TOSCA Magnetostatic
	Non-linear materials
	Simulation No 1 of 1
	212160 elements
	223491 nodes
	30 conductors
	Nodally interpolated fields

Local Coordinates	
Origin: 0.0, 0.0, 0.0	
Local XYZ = Global XYZ	

Average value of Magnetic Field in RF core is 150 Gauss.

Perhaps, this value is acceptable...

Magnetic flux density in RF core

Gap at connection point of clamp = 1 mm

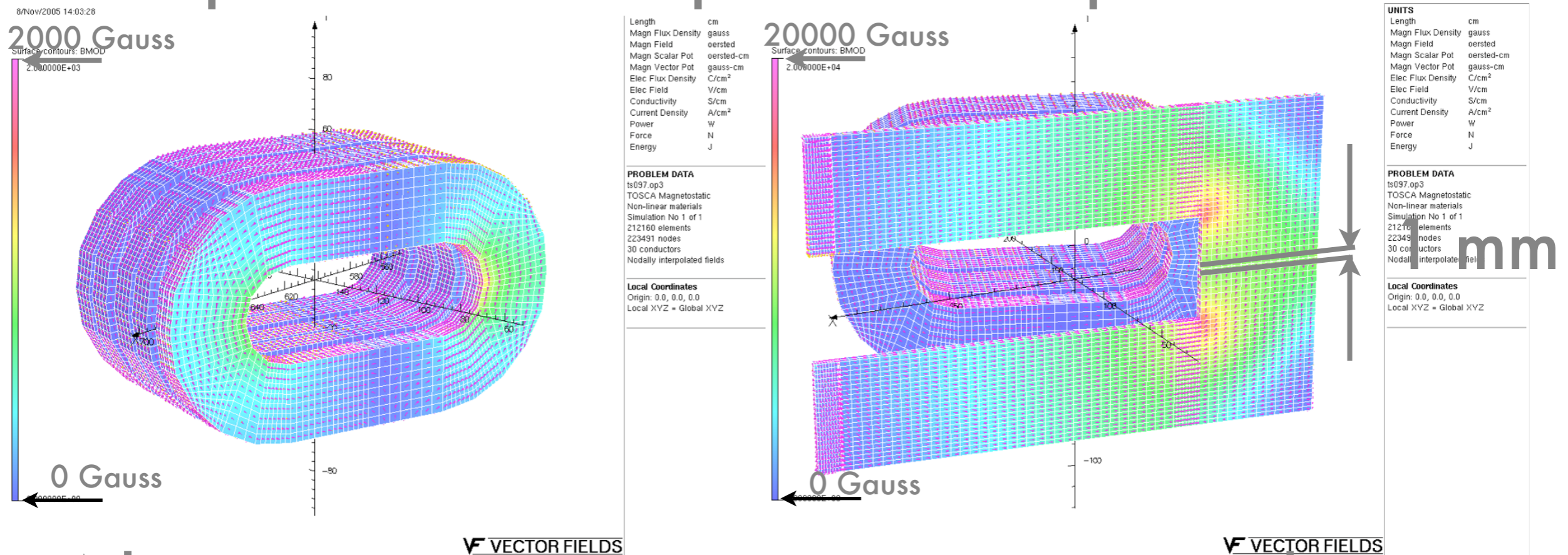

When gap is 1 mm at connection point, the average magnetic flux density at RF core is 350 Gauss. The gap should be less than 0.1 mm.

Configuration

- Engineering design is in progress.
- It will complete in end of this December.

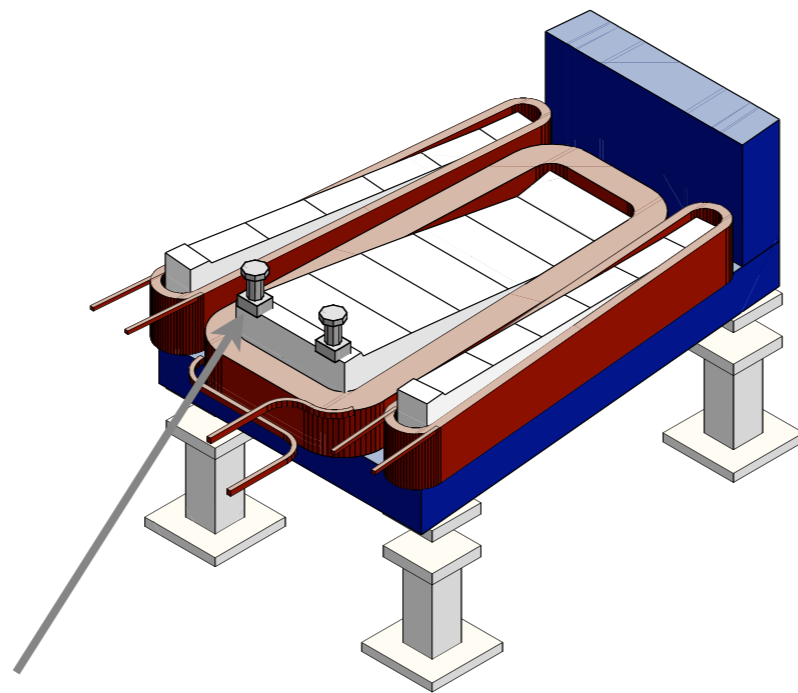

Pole Pillar

Configuration

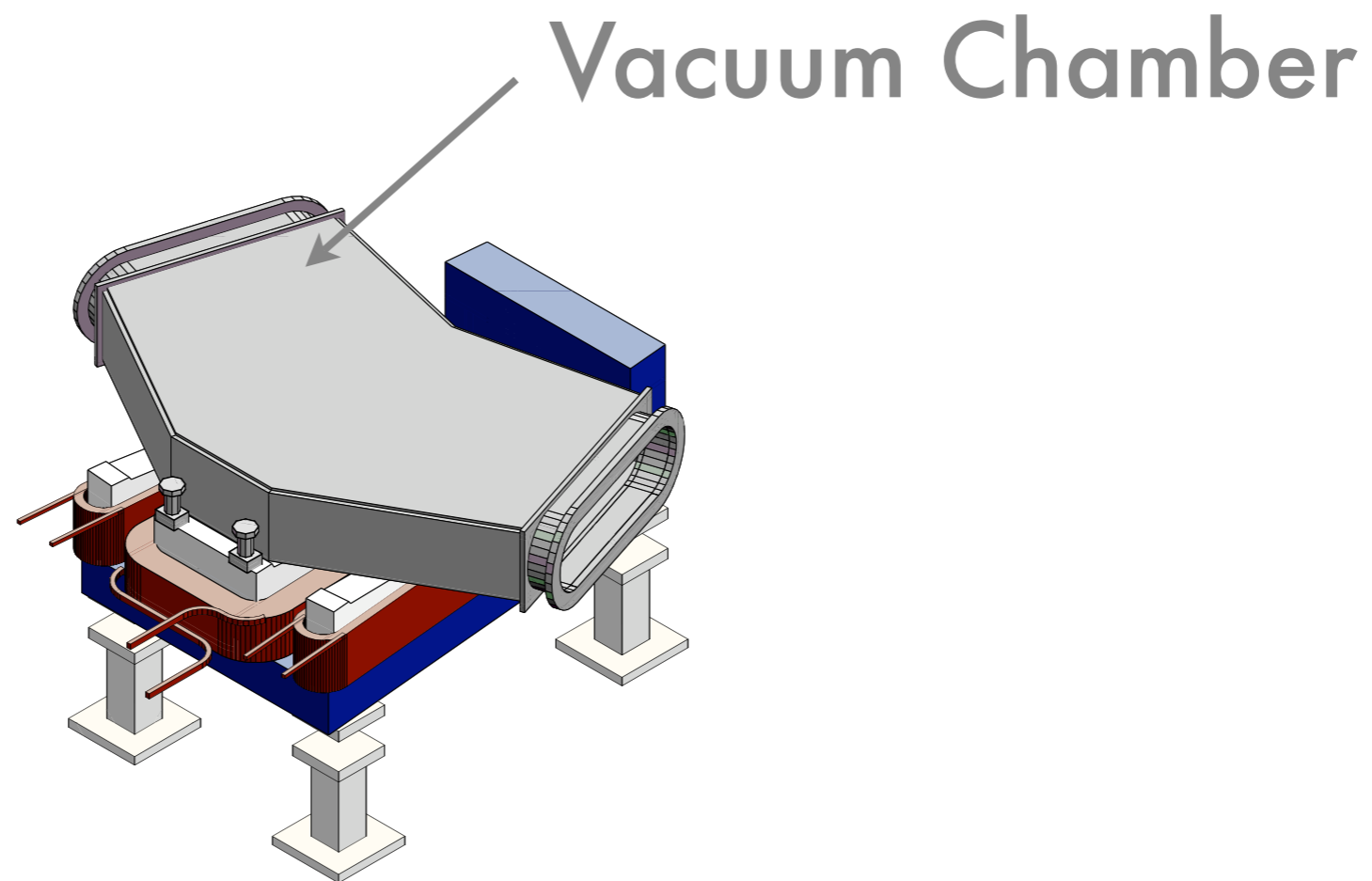

Configuration

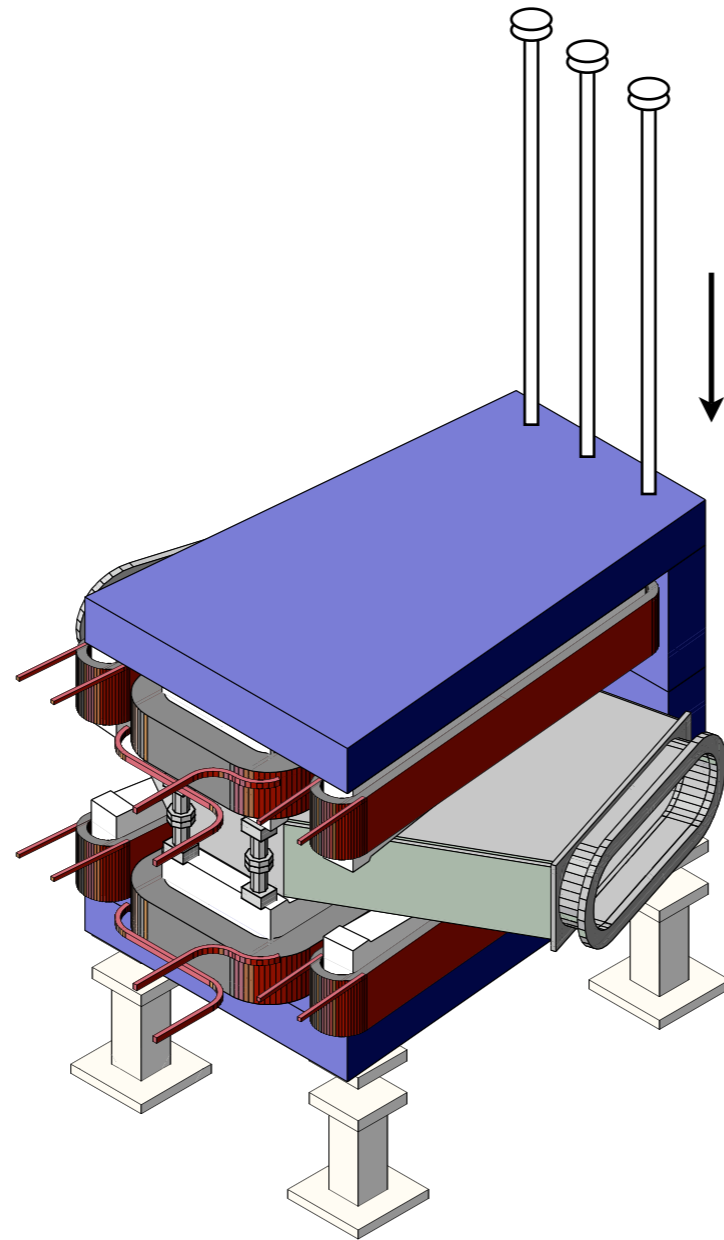

Configuration

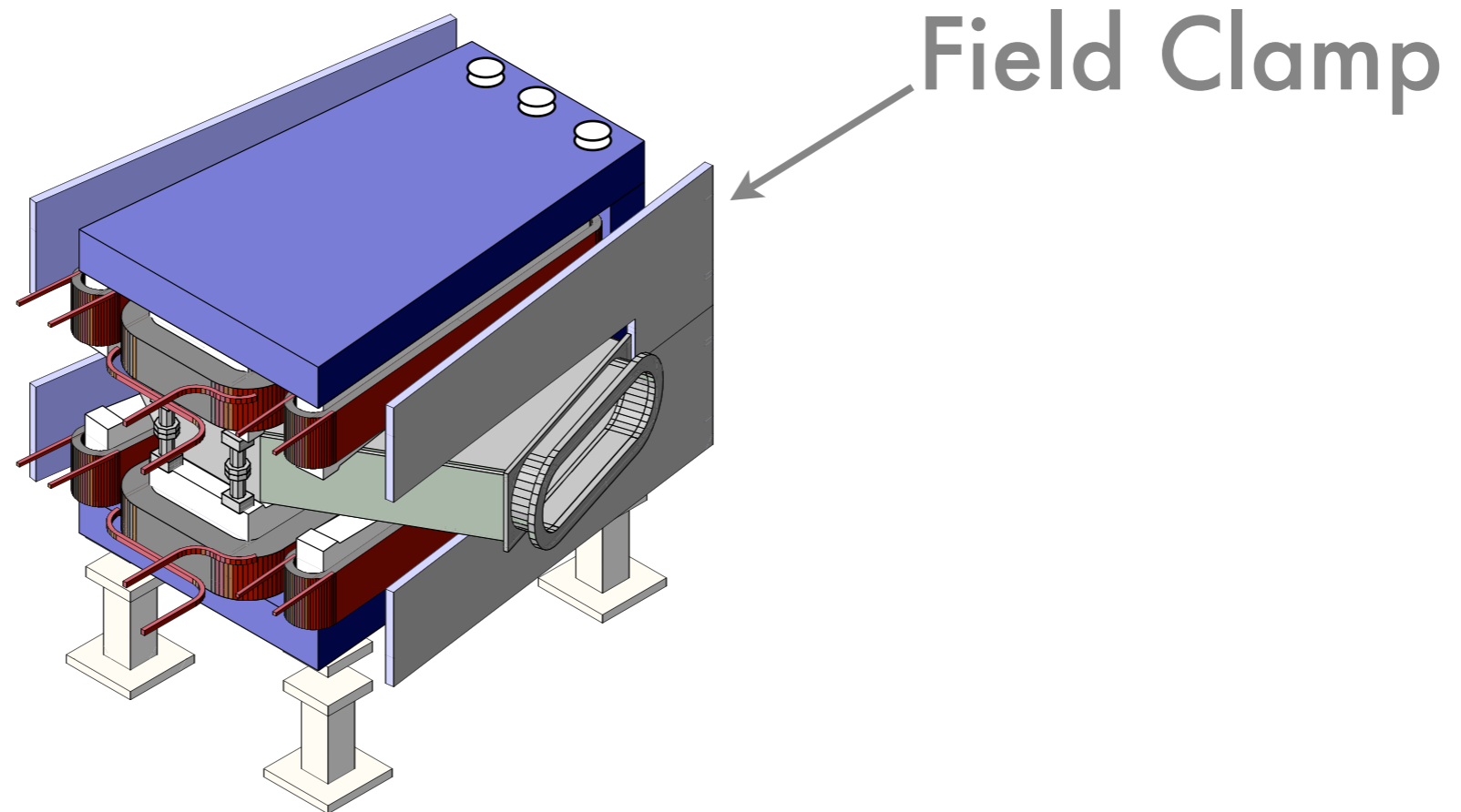

Configuration

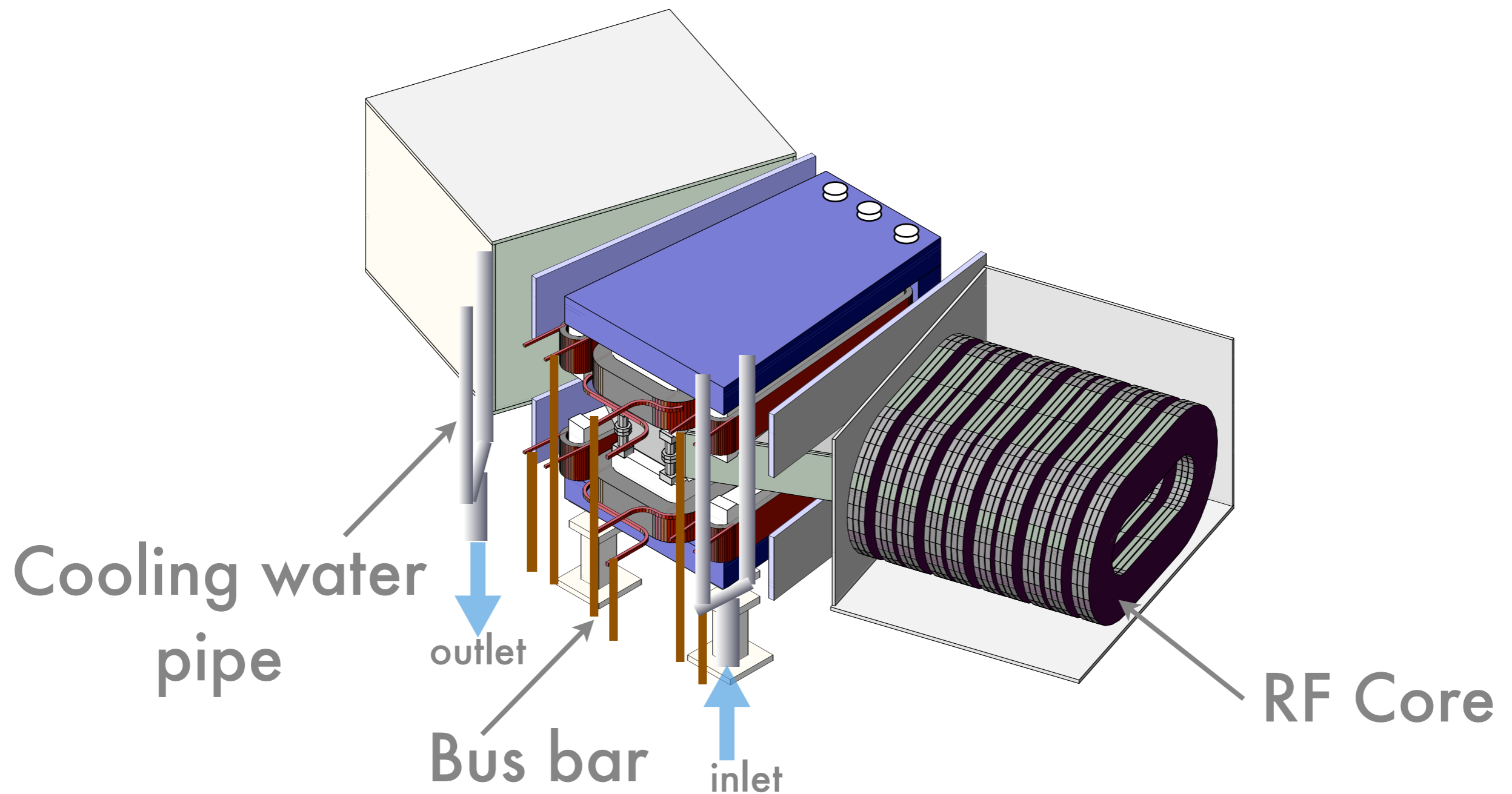

Trim coil

- Trim coils are used to correct magnetic field distribution.
- The study of beam dynamics in large acceptance FFAG ring.

Form of trim coil

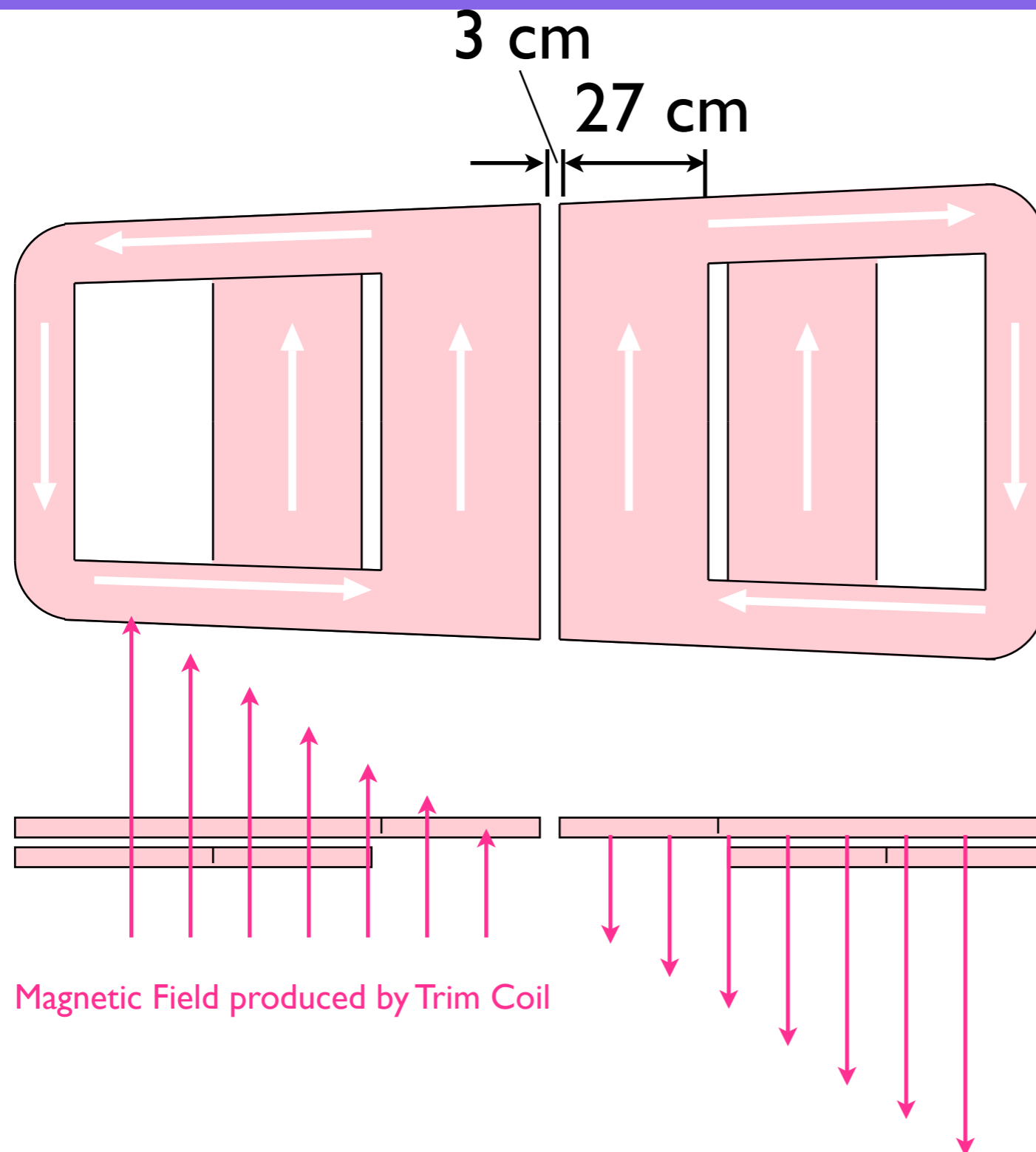

- Flat coil
- Wide conductor

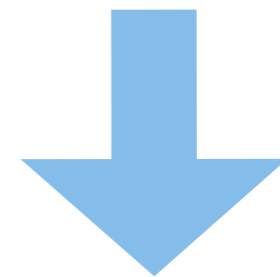

Simple structure !

Cooling method

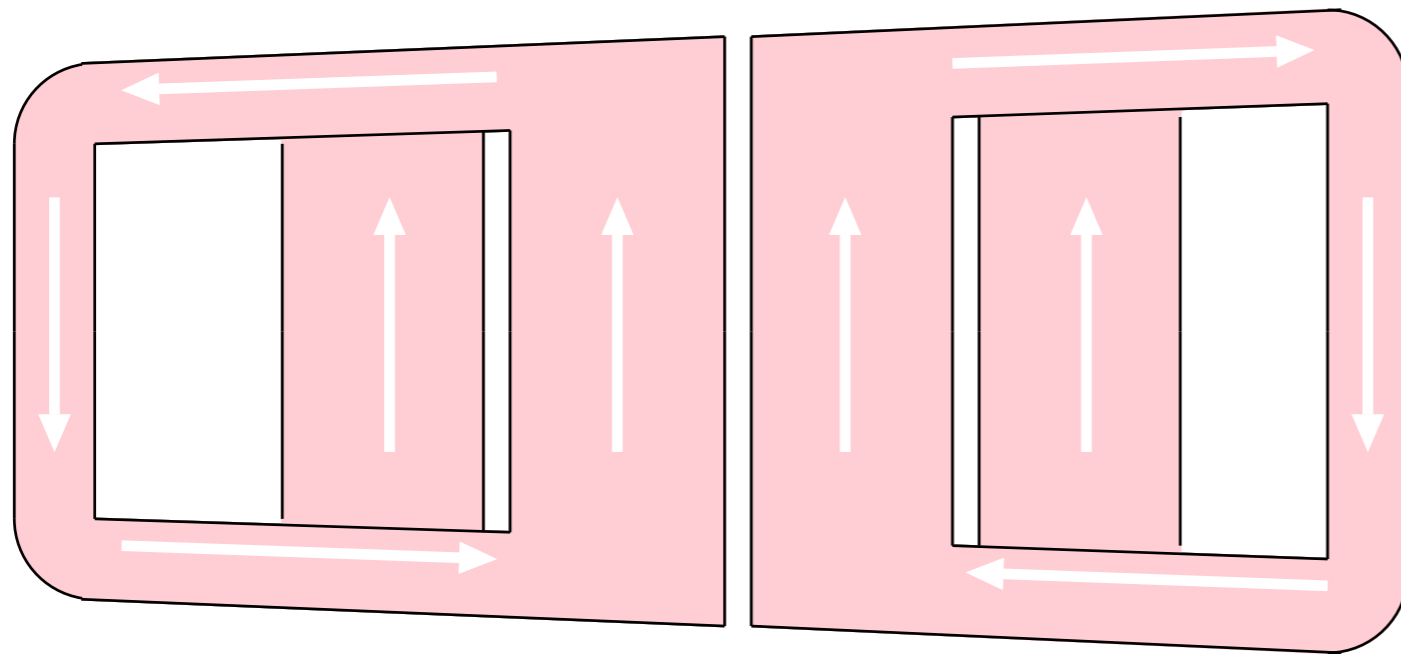

- indirect cooling with copper plate

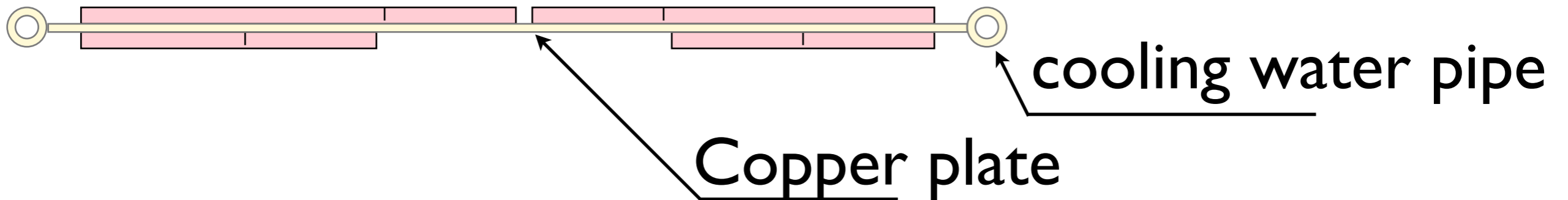

Performance of trim coil

change $k+1$ value

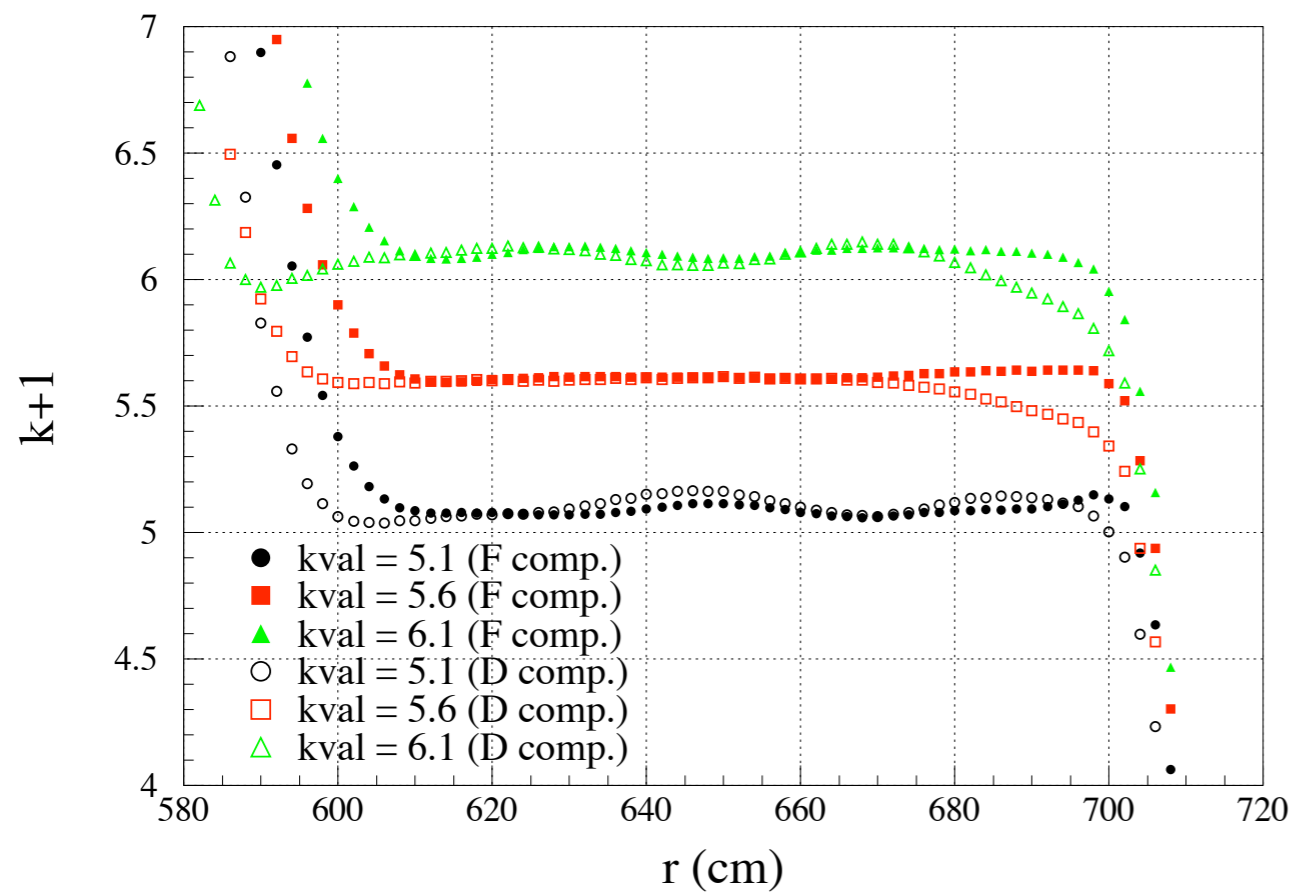

range : 6.1–5.1

change F/D ratio

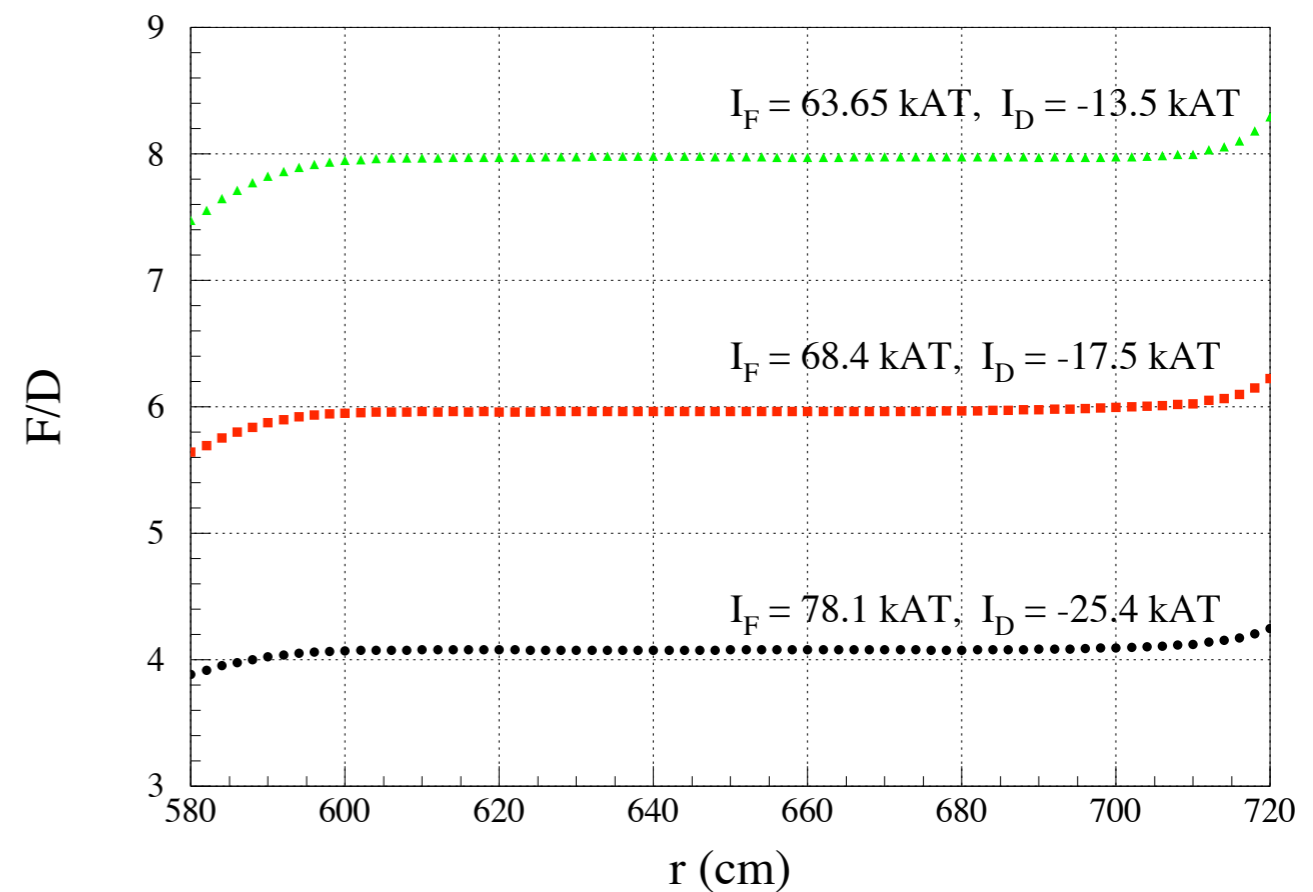

range : 4 – 8

Tune variation

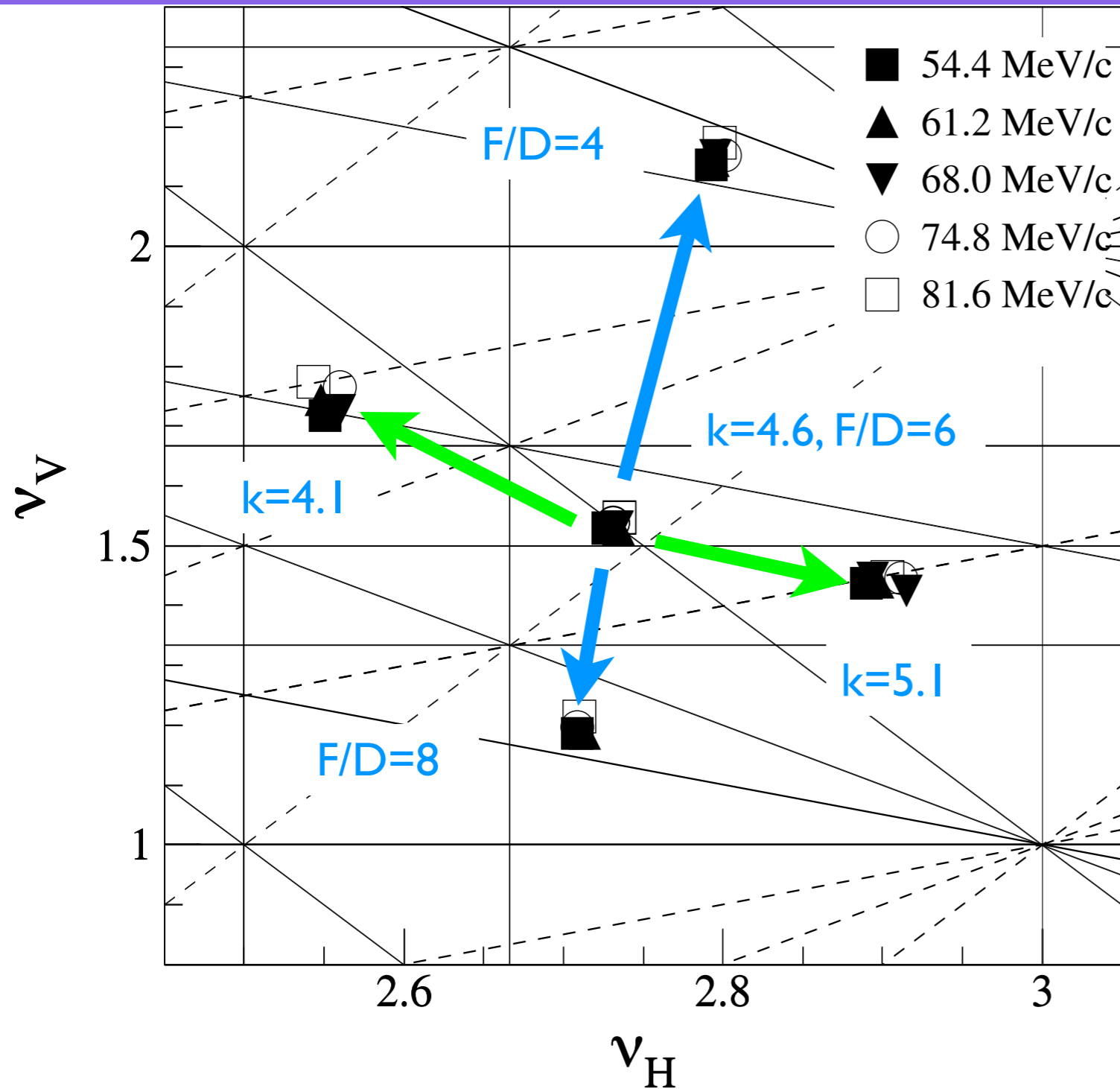

- k changed by ± 0.5

- F/D is fixed to 6.

- F/D ratio are changed by ± 2 .

- k is fixed to 4.6.

Comparison of continuous field (POISSON field) and discontinuous field (trim coil field)

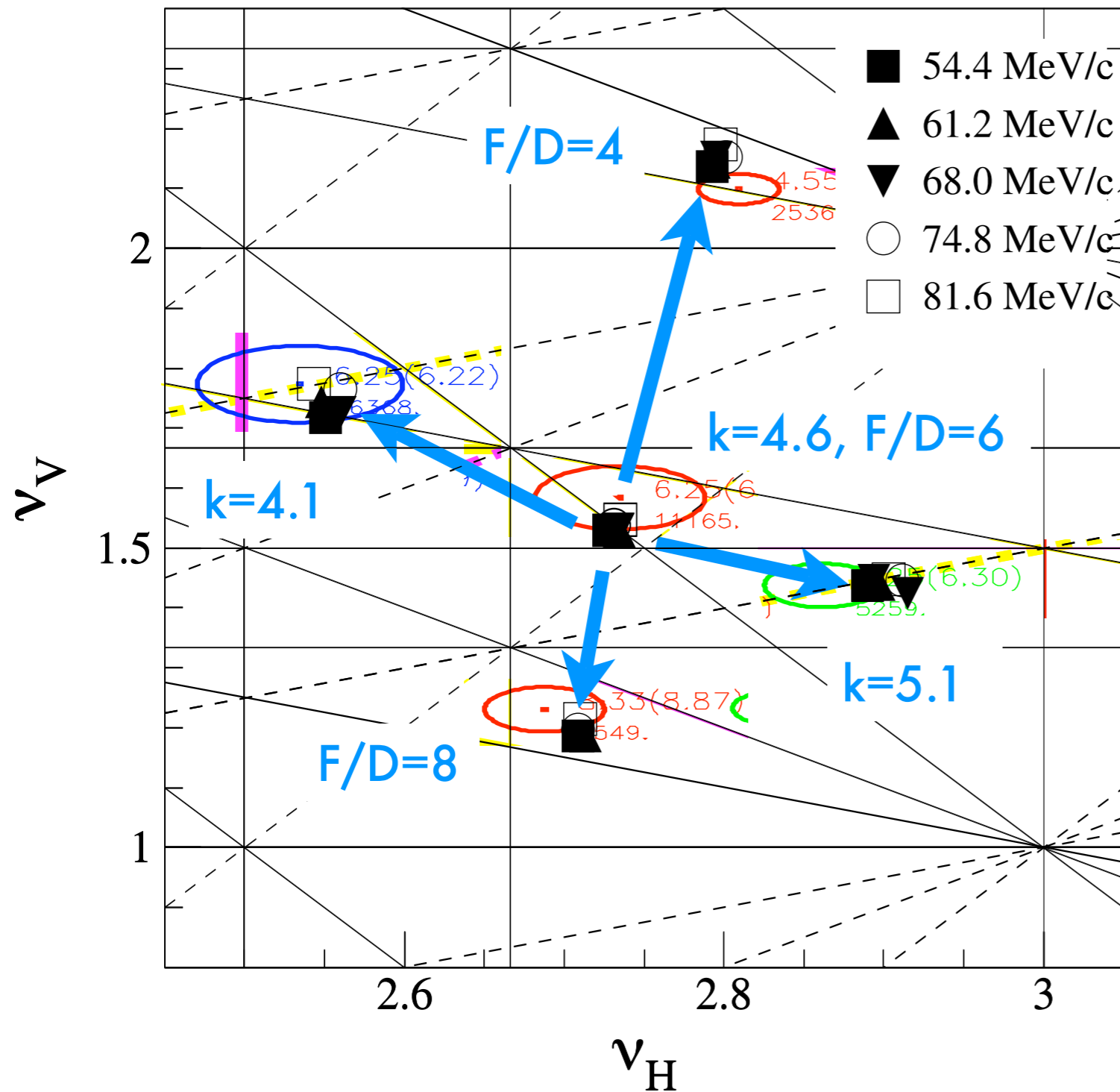

- Good consistency has been obtained.

Momentum vs 4D Acceptance

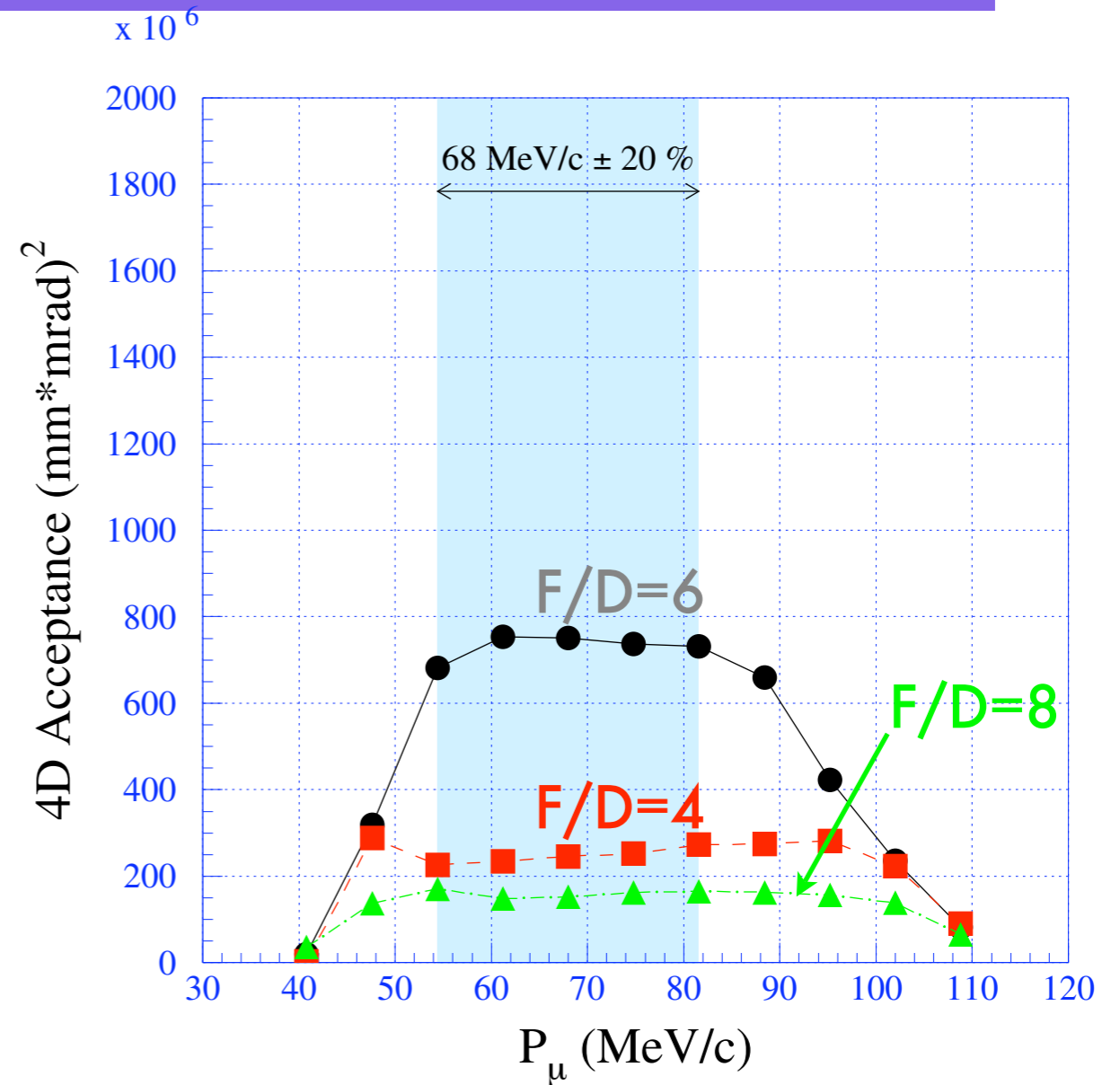
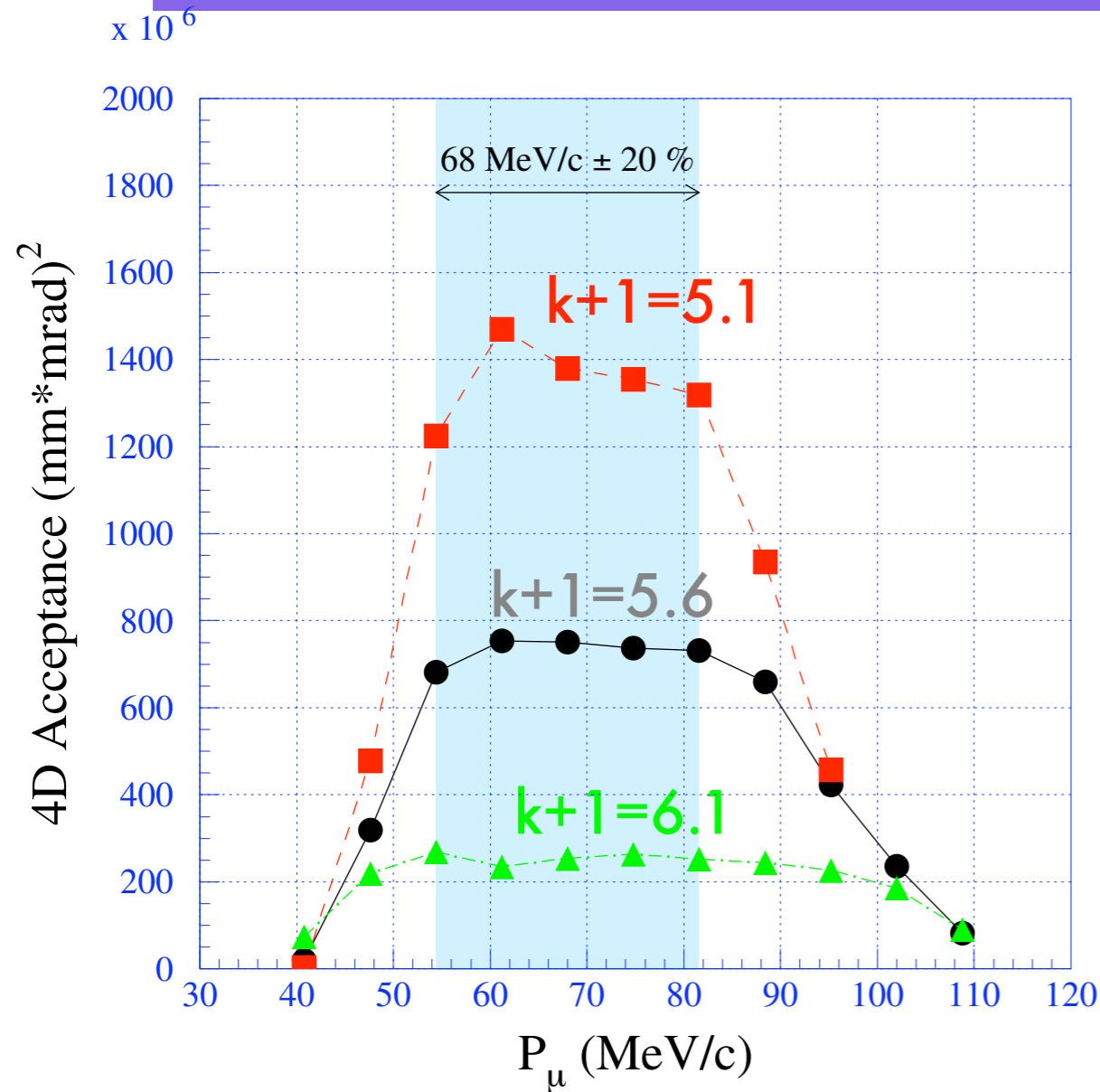

Momentum Acceptance of 20 % are achieved even by 4 trim coil set.

Magnet Parameters

Weight of magnet		17 t / 1 cell
Current (per 1 coil)	F magnet	1750 A / 84000 A*T
	D magnet	1034 A / 30000 A*T
Power		100 kW / 1 cell
Flow rate of cooling water	F magnet	61.7 ℓ / min
	D magnet	38.3 ℓ / min
Pressure drop (per 1path)	F magnet	4.8 kg / cm ²
	D magnet	1.9 kg / cm ²

Important decision : color

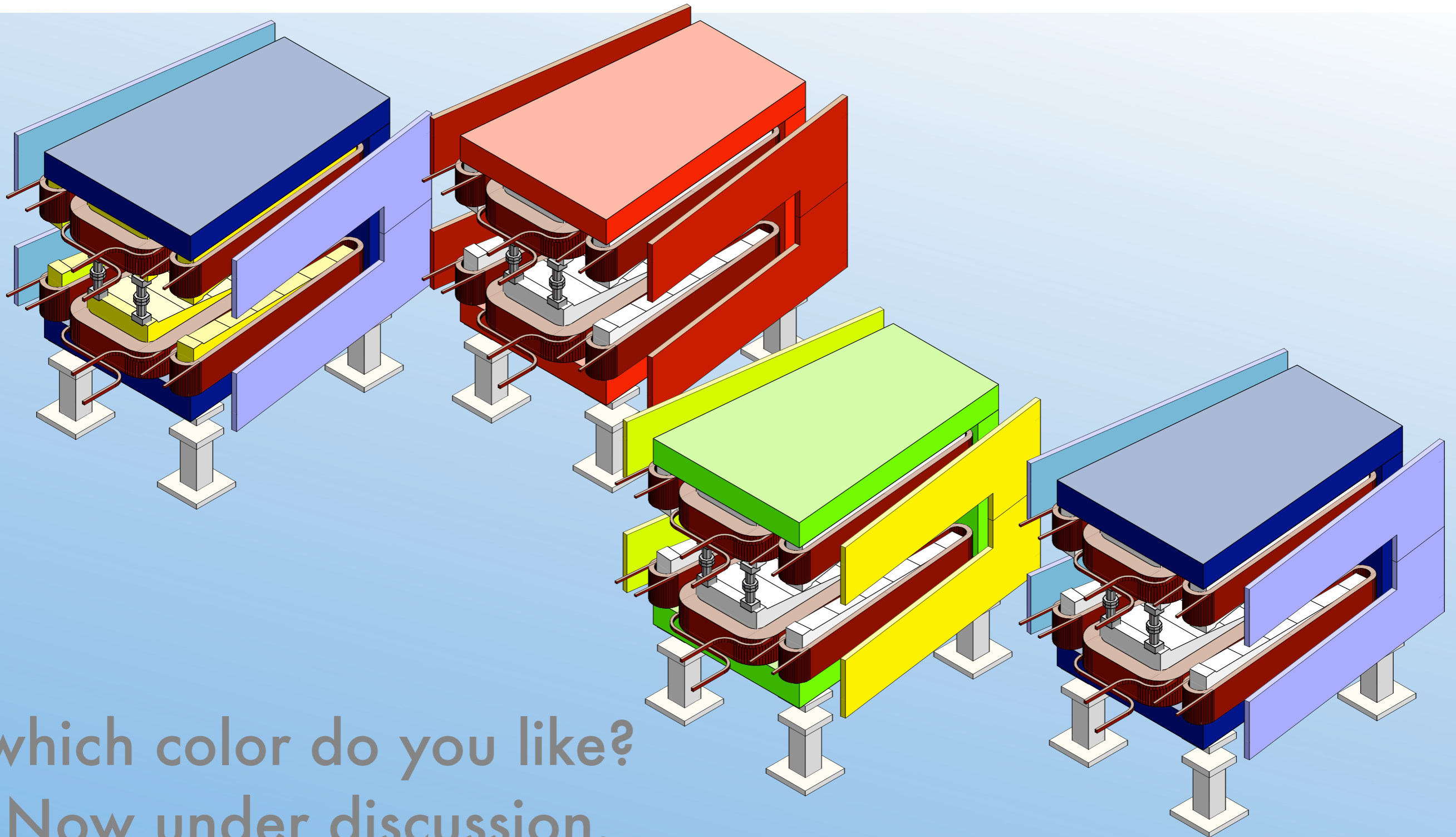

which color do you like?
Now under discussion.

Conclusion

- Design of PRISM FFAG Magnet has been almost finished.
- Reduction of 4D acceptance is small due to individual difference of magnet.
- Magnetic flux density in RF core is sensitive to gap size of connection point of field clamp
- Engineering design is underway. (finished at end of this Dec.)