

# Status of FFAG Complex at KURRI

M. Tanigaki, Y. Mori, K. Mishima, S. Shiroya, M. Inoue,  
RRI, Kyoto University  
Y. Ishi, S. Fukumoto, Mitsubishi Electric Company  
S. Machida, KEK

# KART Project

(Kumatori Accelerator driven Reactor Test)

**Purpose: Feasibility study of ADS**

- $k_{\text{eff}}$  for  $E_p = 20 \sim 150$  MeV
- FFAG accelerator as proton driver for ADS

Five-year project (2002~2007)

# FFAG Complex for KART

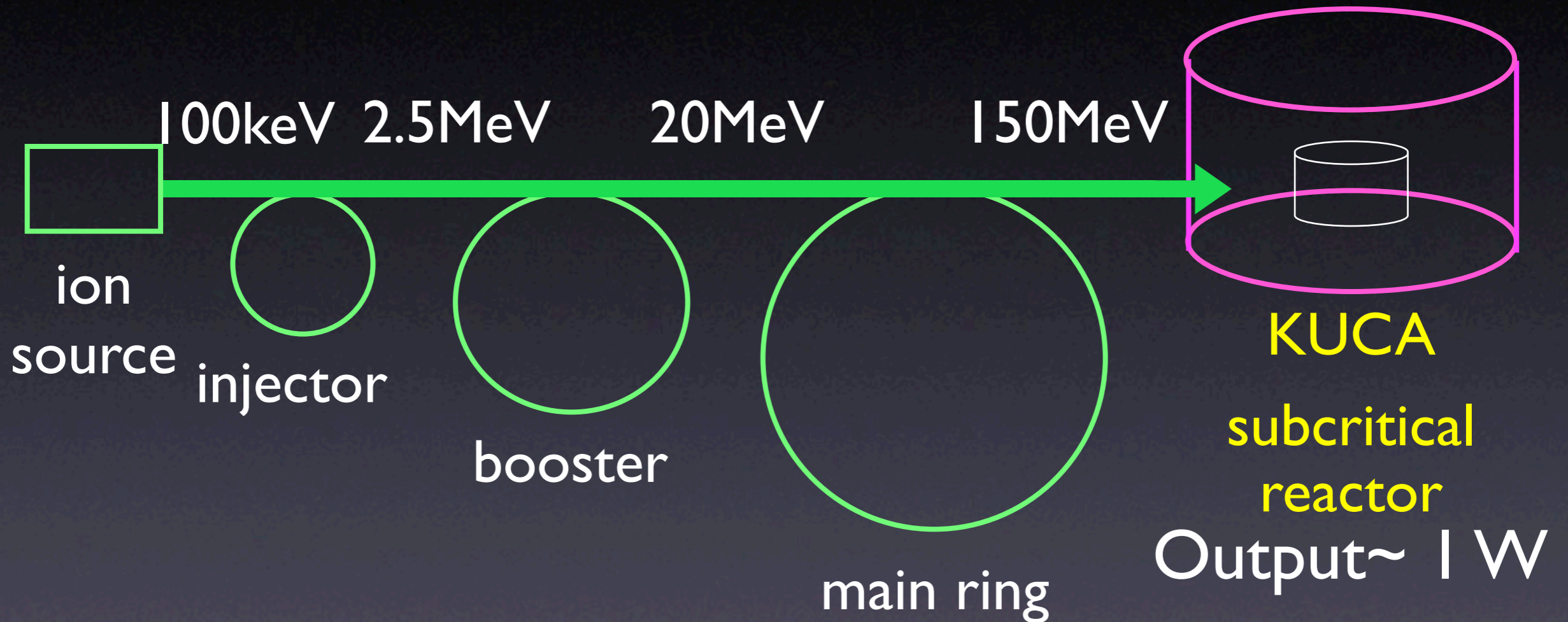

Repetition Rate : 120 Hz

# FFAG complex

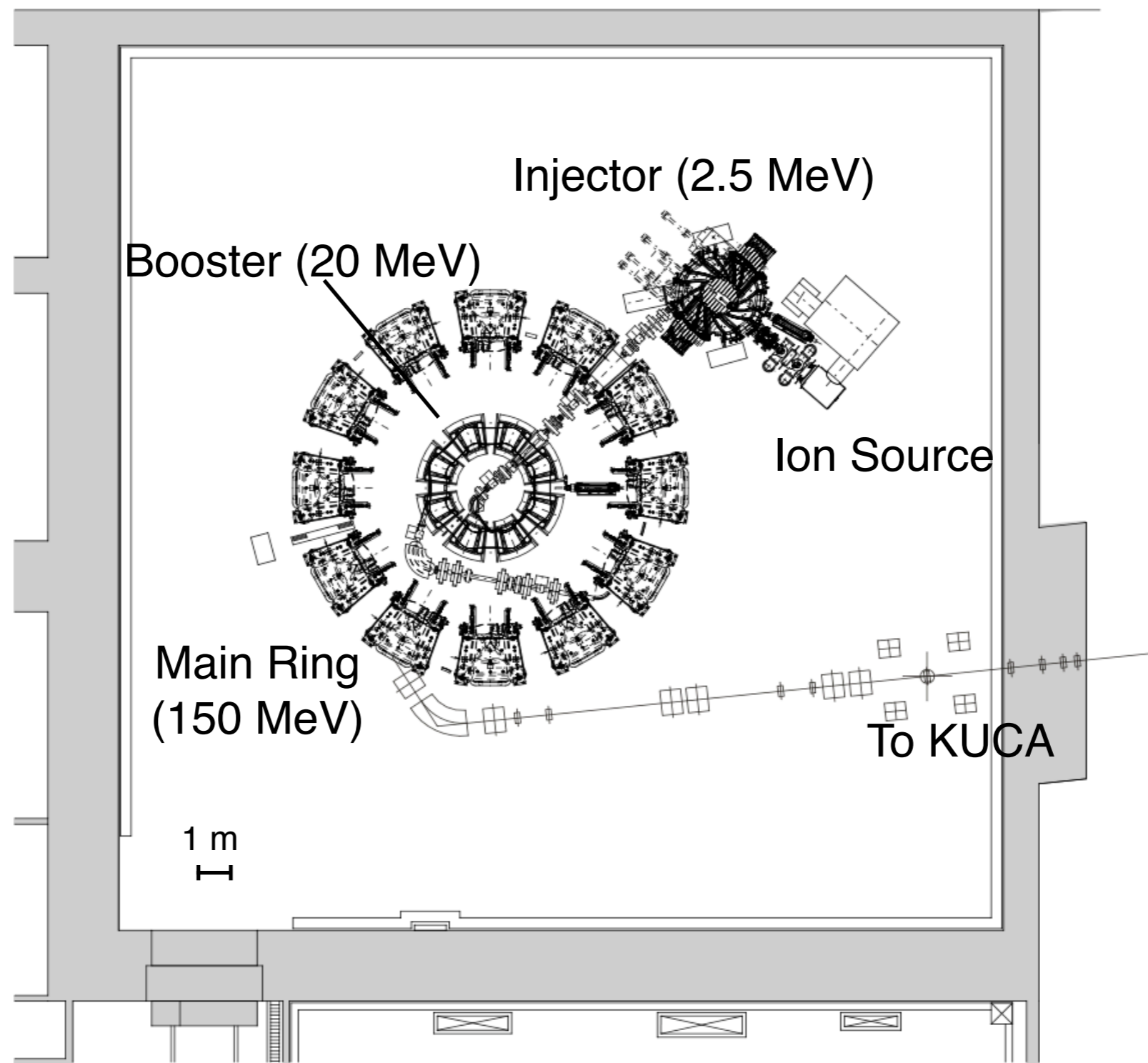

# Parameters for FFAG complex

	Injector	Booster	Main
$E_{inj}$	100 keV	2.5 MeV	20 MeV
$E_{ext}$	2.5 MeV	20 MeV	150 MeV
Lattice type	Spiral	Radial DFD	Radial DFD
# of cells	8	8	12
Acc. scheme	Induction	RF	RF
$k$	2	2.45	7.5
coil/pole	coil	pole	pole
$p_{inj}/p_{ext}$	5.00	2.84	2.83
$r_{inj}$	0.60 m	1.27 m	4.54 m
$r_{ext}$	0.99 m	1.74 m	5.12 m

# Injector

Energy	0.4 ~ 2.5 MeV
$\langle I \rangle$	0~2 $\mu\text{A}$
Rep. rate	0.1 ~ 1 kHz
# of sectors	8
Spiral angle	42 deg.
Size	3.5 m $\times$ 6 m $\times$ 2.5 m
Weight	30 t

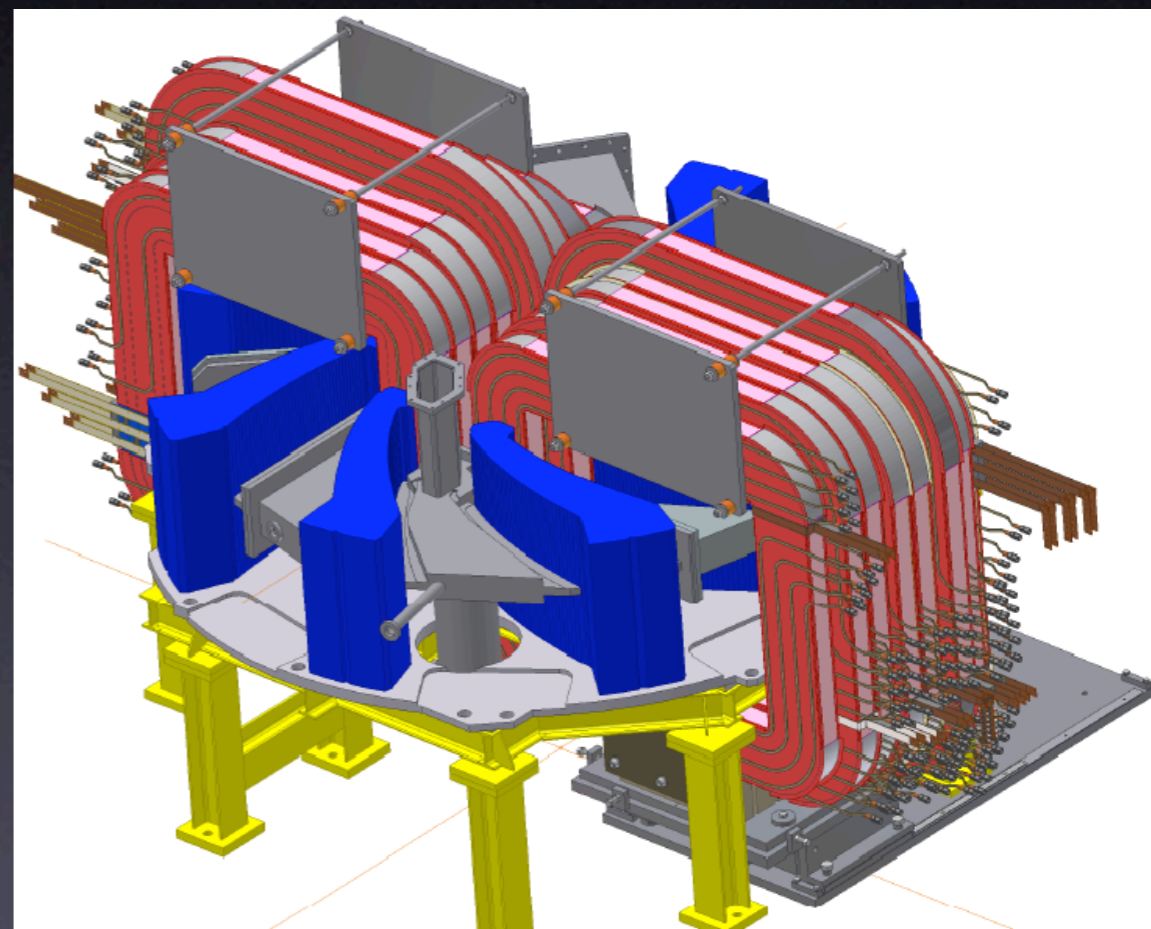

# Spiral Sector Magnet

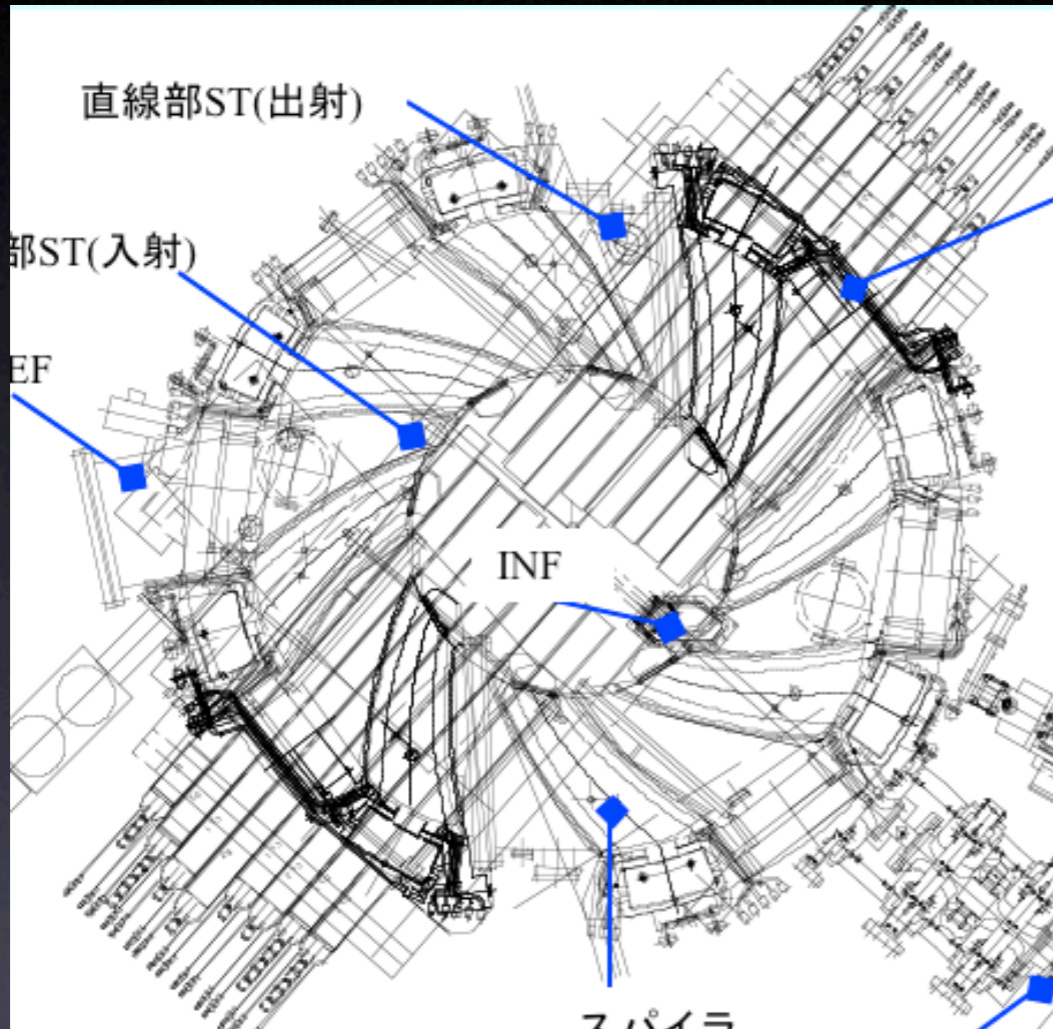

8 Spiral Sectors

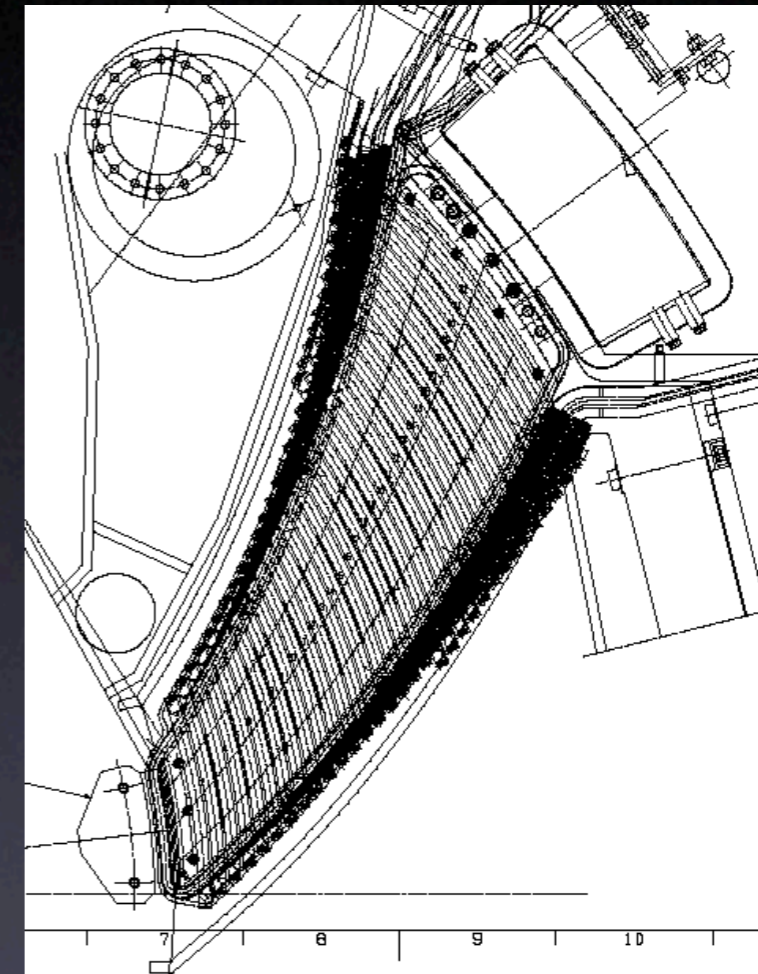

Spiral Angle : 42 deg.  
32 Coils for Variable  $k$ -index

# Tune Diagram

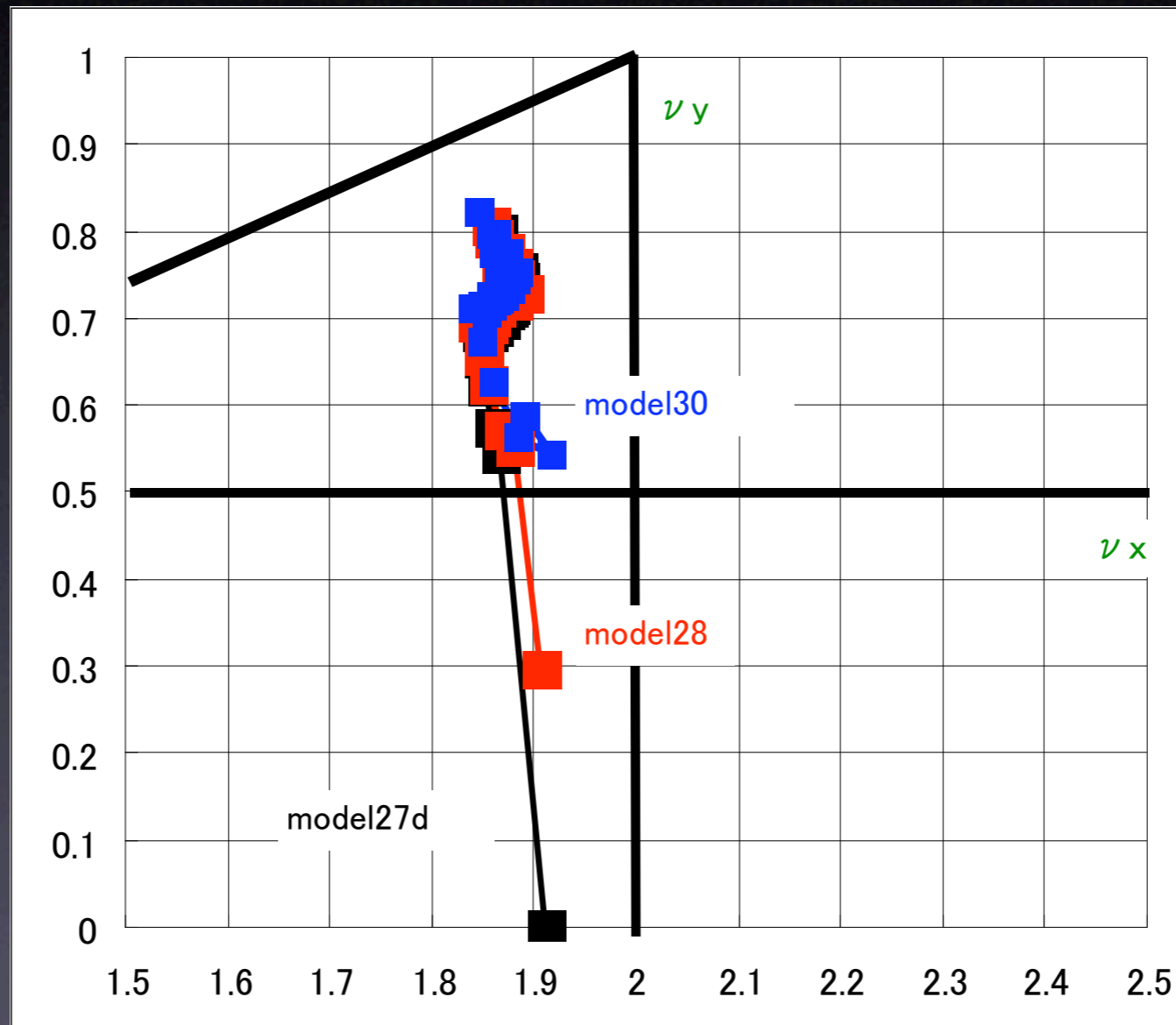

# Spiral Sector Magnet



# Coils for variable $k$

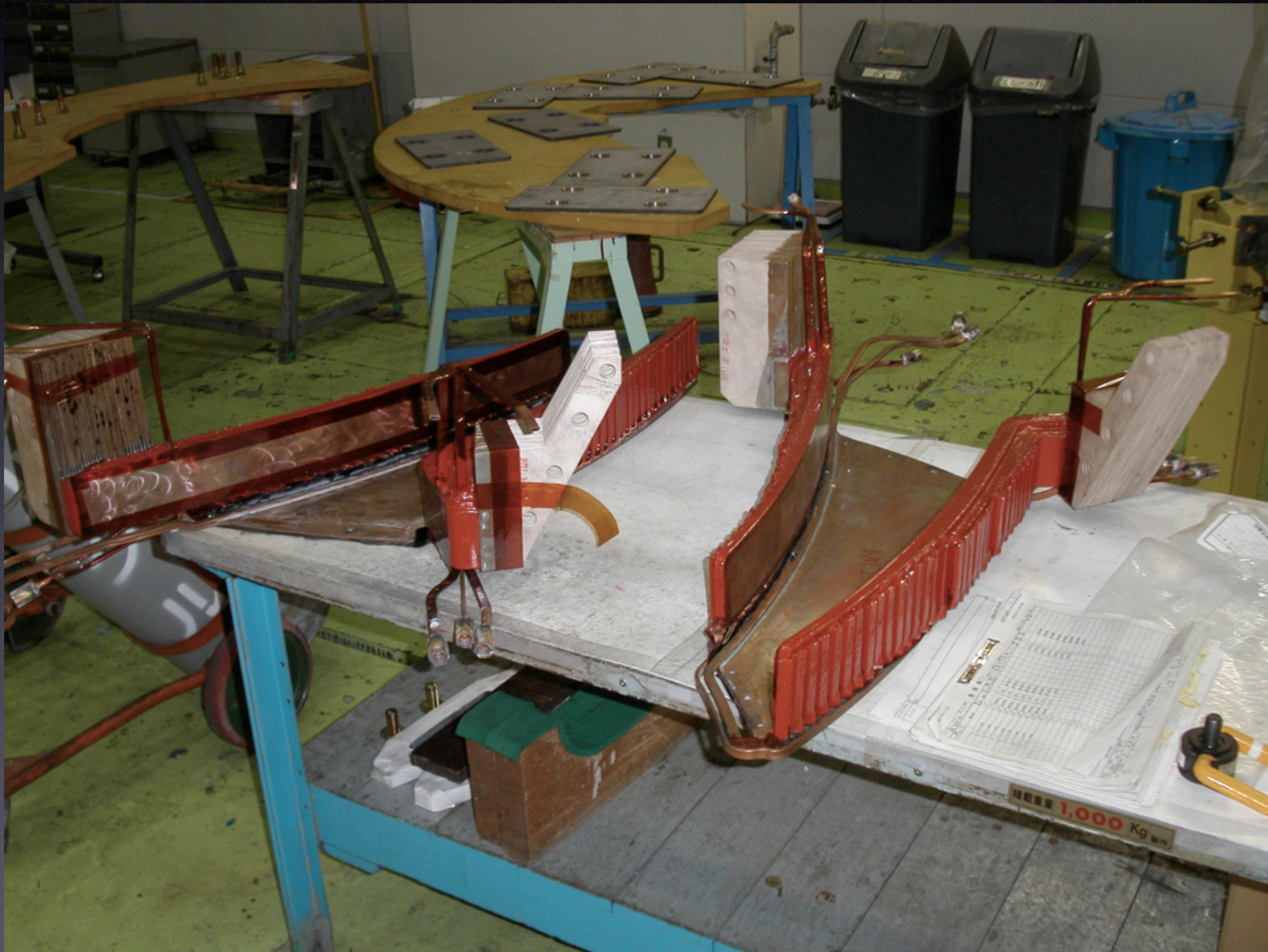

# Coils for variable $k$

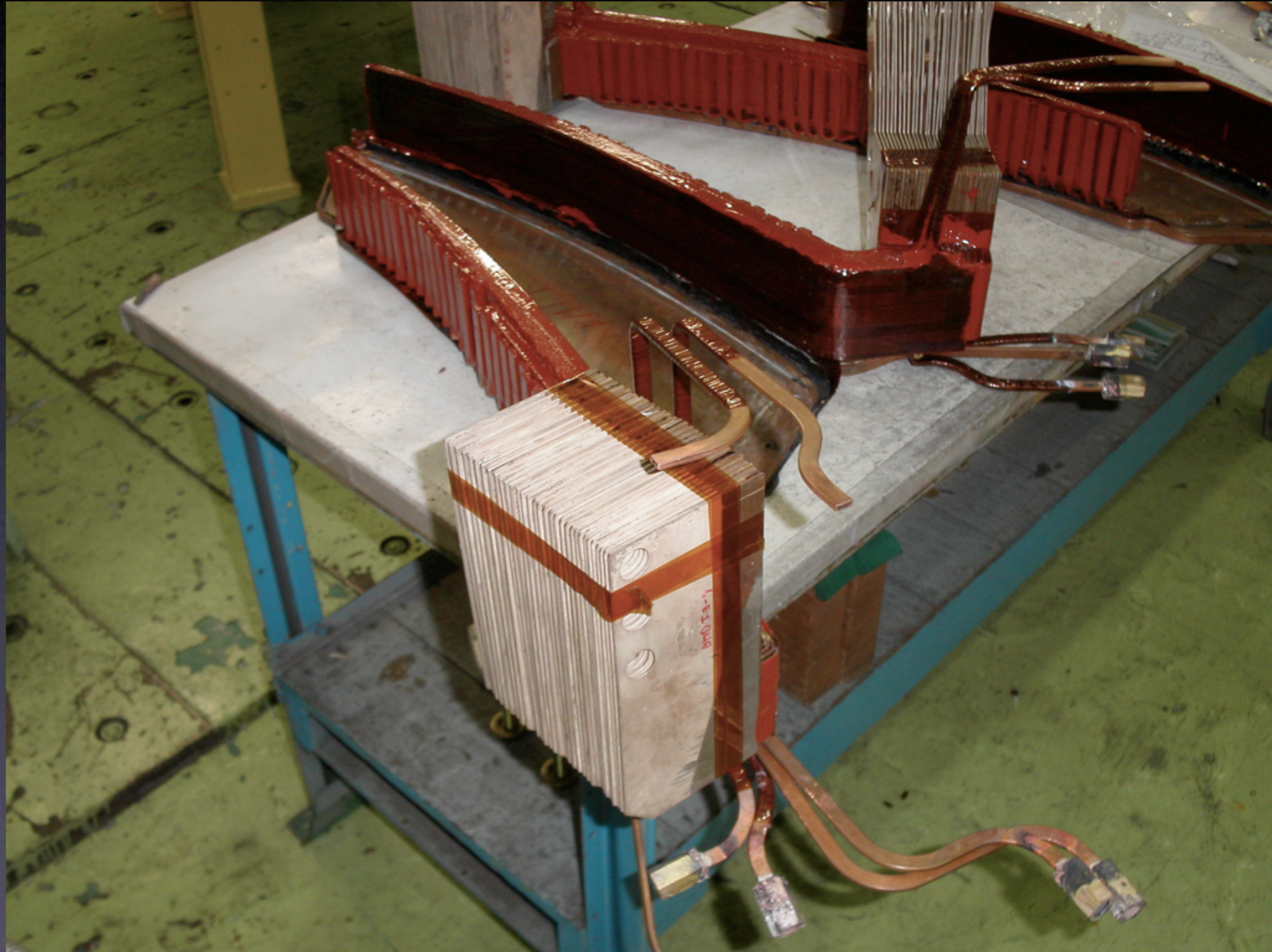

# Magnet



# Magnetic Field Measurement

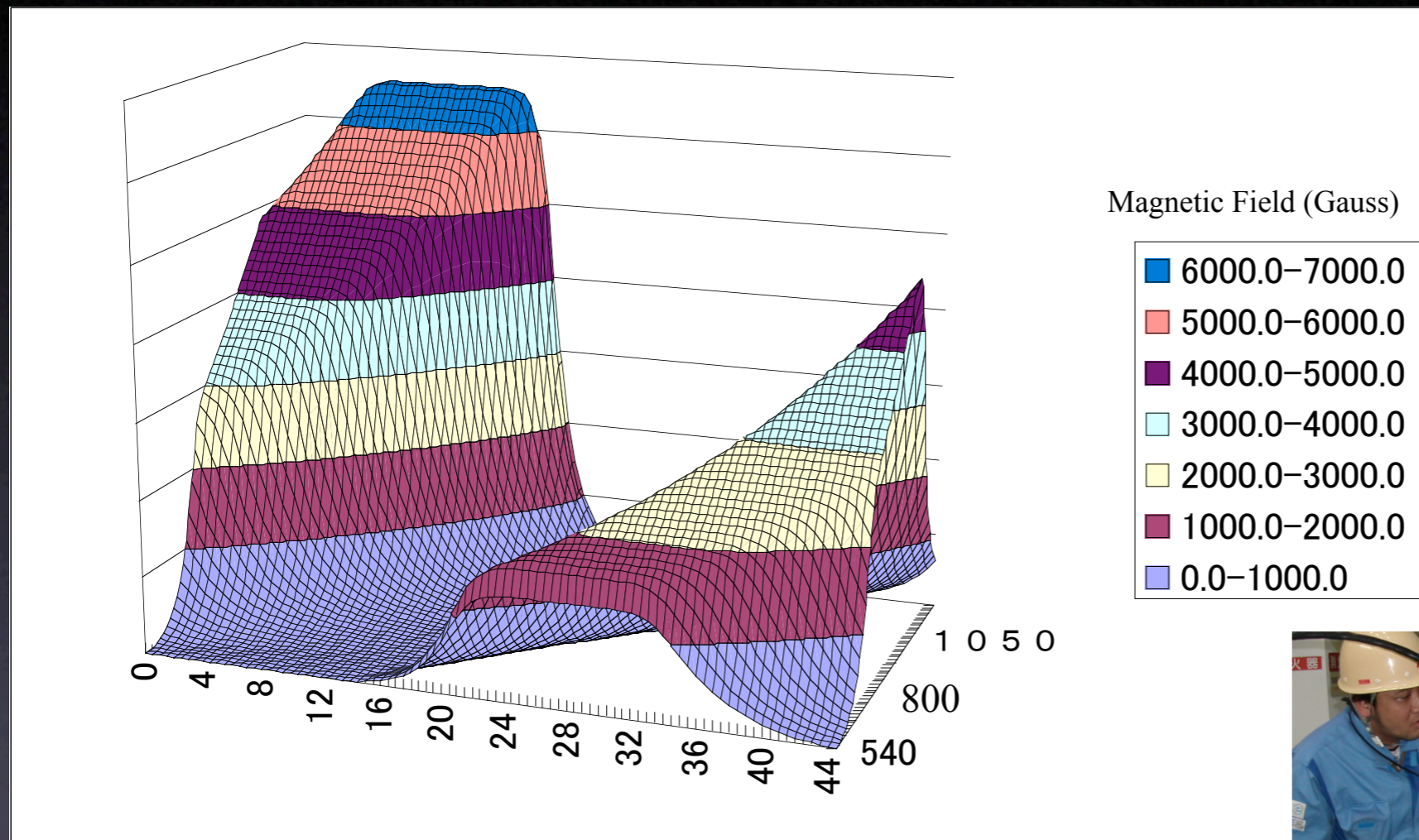

# Voltage Pattern for Acceleration

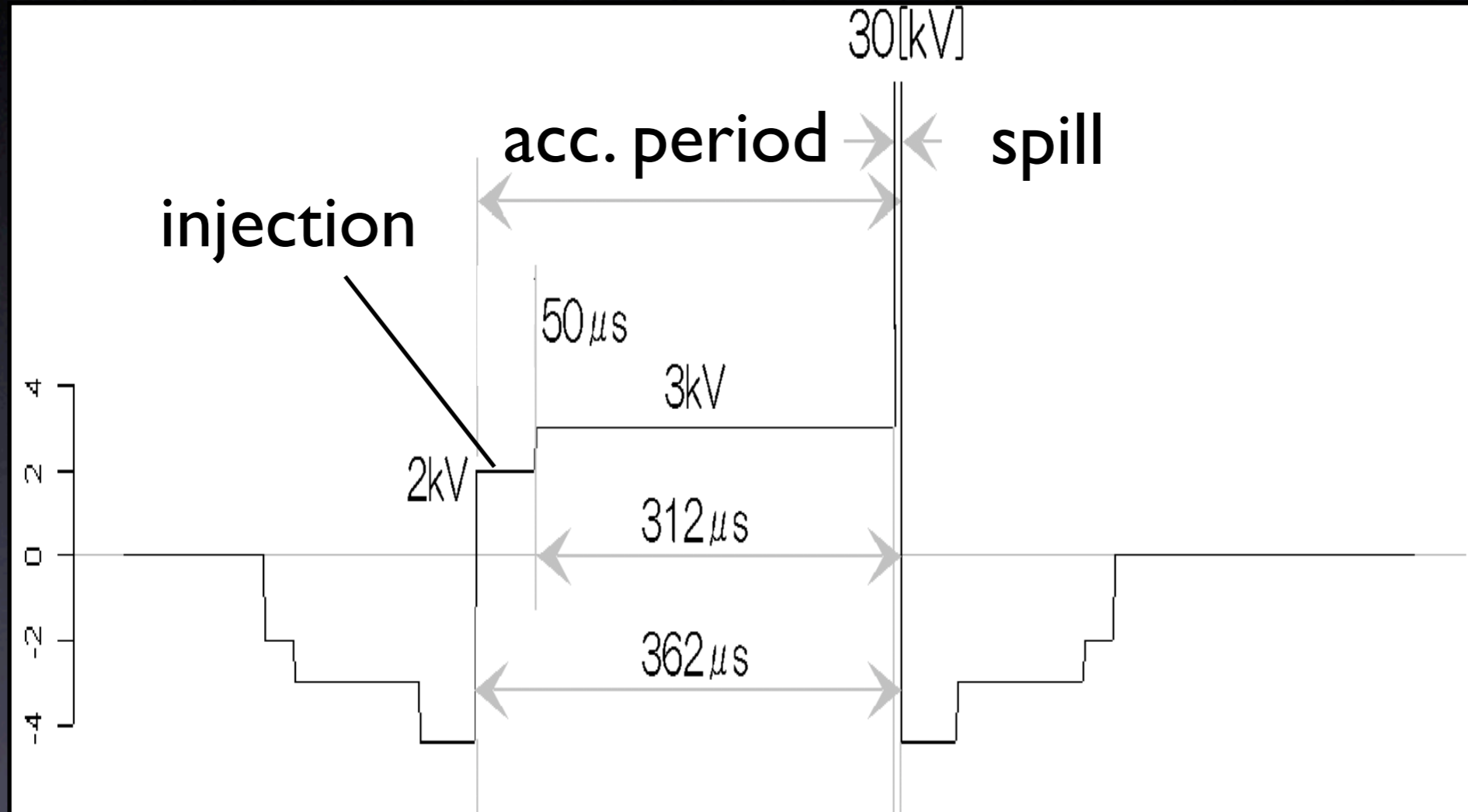

Power saving

Beam pulse compression

# Induction Core



# Booster

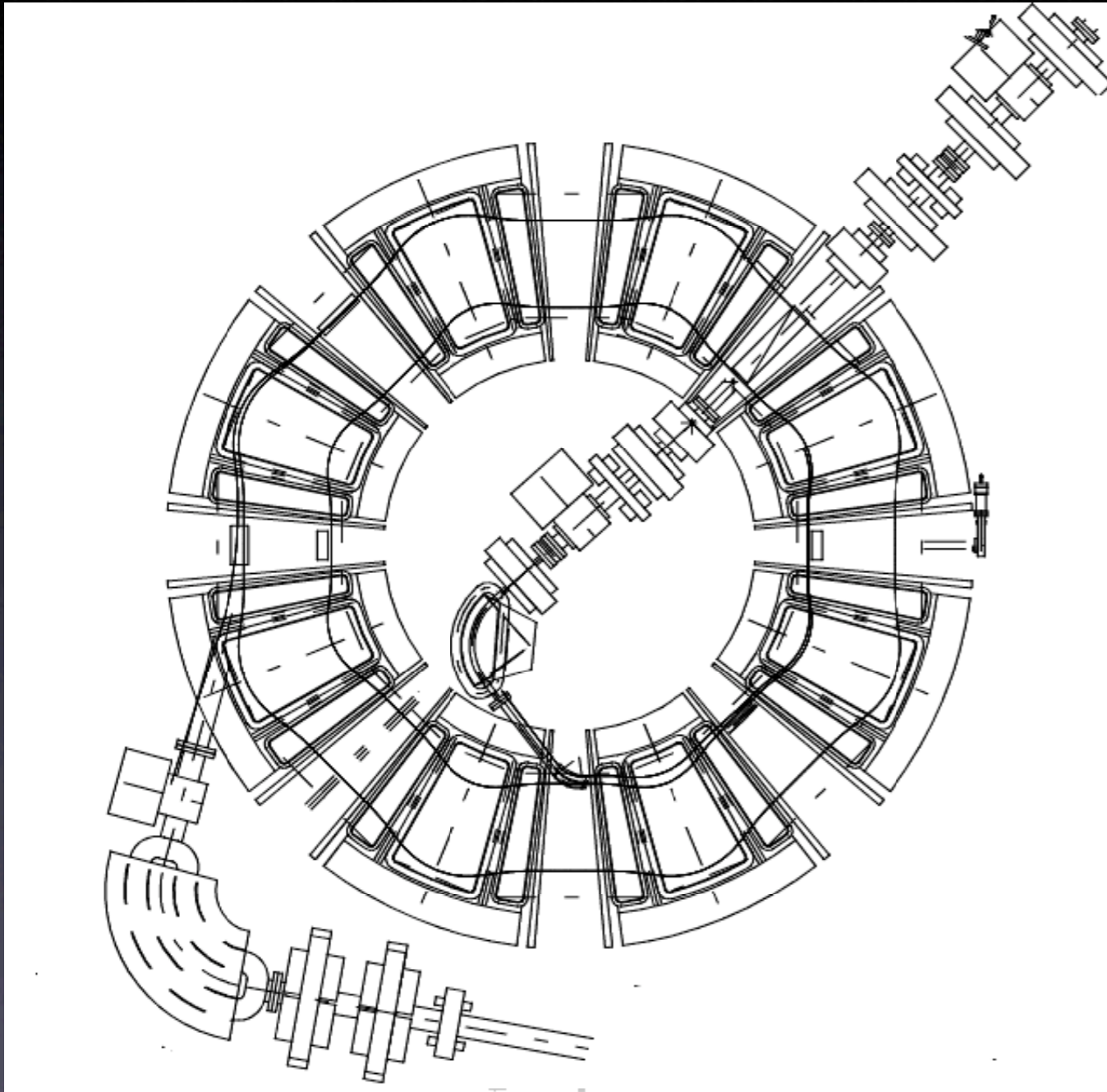

- Radial sector type (DFD)
- RF acceleration
- Fixed  $k$  with pole shape

# Magnet

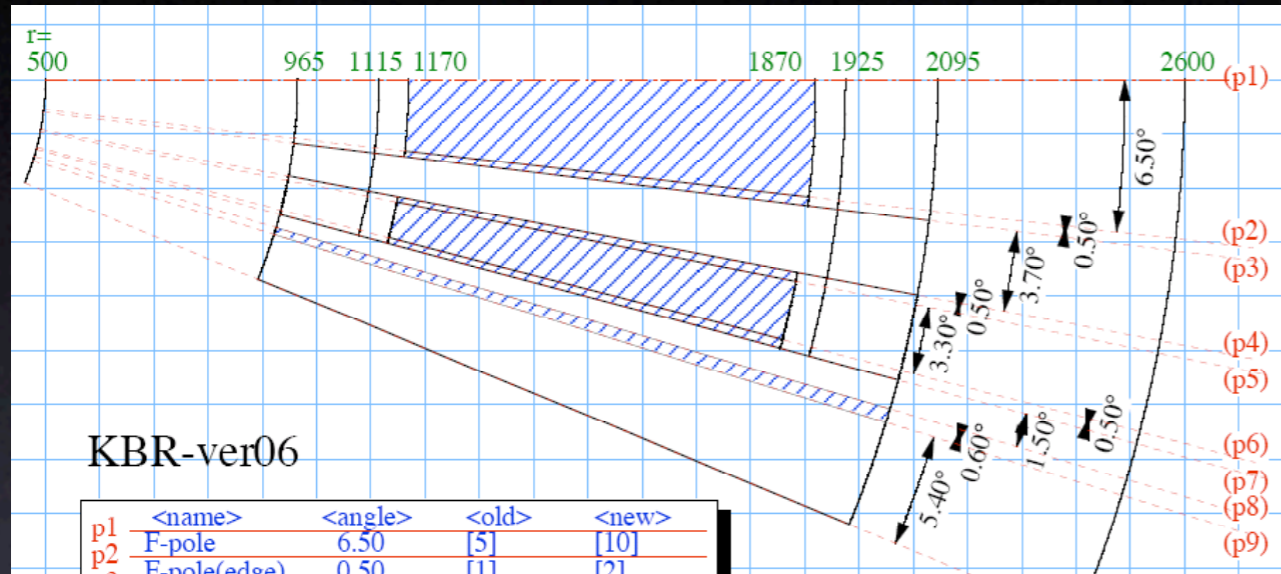

KBR-ver06

	<name>	<angle>	<old>	<new>
p1	F-pole	6.50	[5]	[10]
p2	F-pole(edge)	0.50	[1]	[2]
p3	coil gap	3.70	[2]	[5]
p4	D-pole(edge)	0.50	[1]	[2]
p5	D-pole	3.30	[3]	[3]
p6	D-pole(edge)	0.50	[1]	[2]
p7	air	1.50	[1]	[2]
p8	iron sheeld	0.60	[1]	[2]
p9	air	5.40	[4]	[5]

Surface contours: BMOD

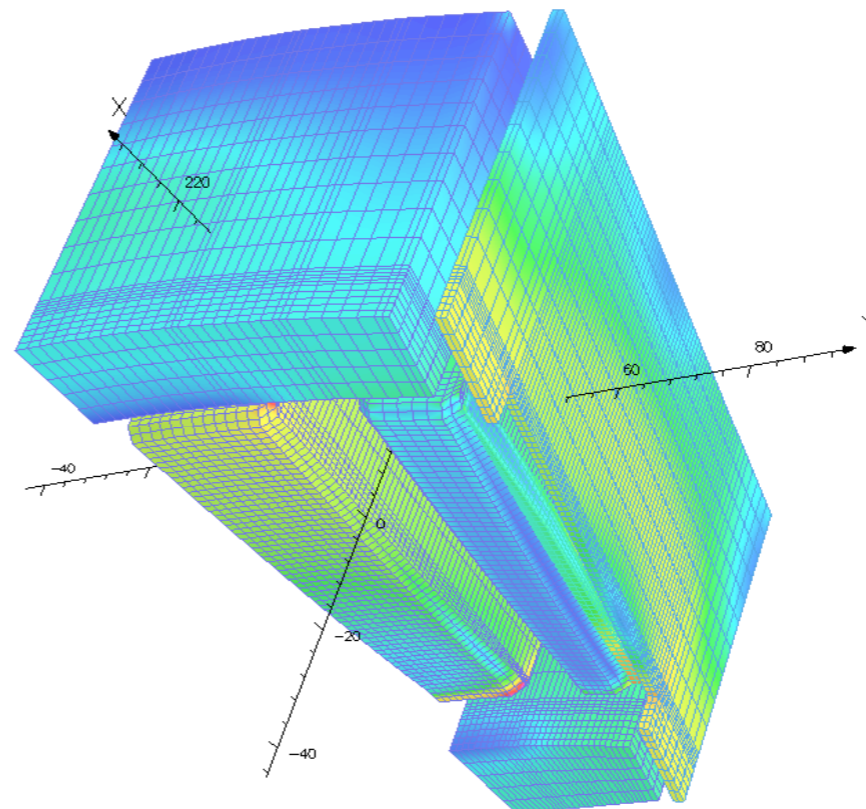
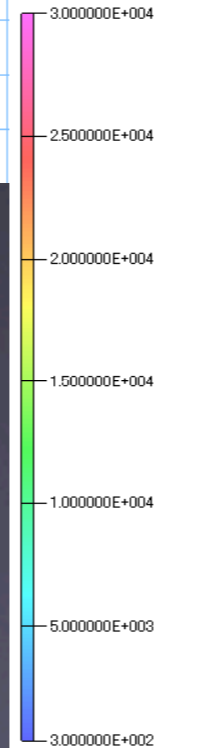

UNITS	
Length	cm
Magn Flux Density	gauss
Magn Field	oersted
Magn Scalar Pot	oersted cm
Magn Vector Pot	gauss cm
Elec Flux Density	C cm <sup>-2</sup>
Elec Field	V cm <sup>-1</sup>
Conductivity	S cm <sup>-1</sup>
Current Density	A cm <sup>-2</sup>
Power	W
Force	N
Energy	J

**PROBLEM DATA**  
 BST\_BD-16.OP3  
 TOSCA Magnetostatic  
 Non-linear materials  
 Simulation No 1 of 1  
 104125 elements  
 111800 nodes  
 48 conductors  
 Nodally interpolated fields

**Local Coordinates**  
 Origin: 0.0, 0.0, 0.0  
 Local XYZ = Global XYZ

# Tune Diagram

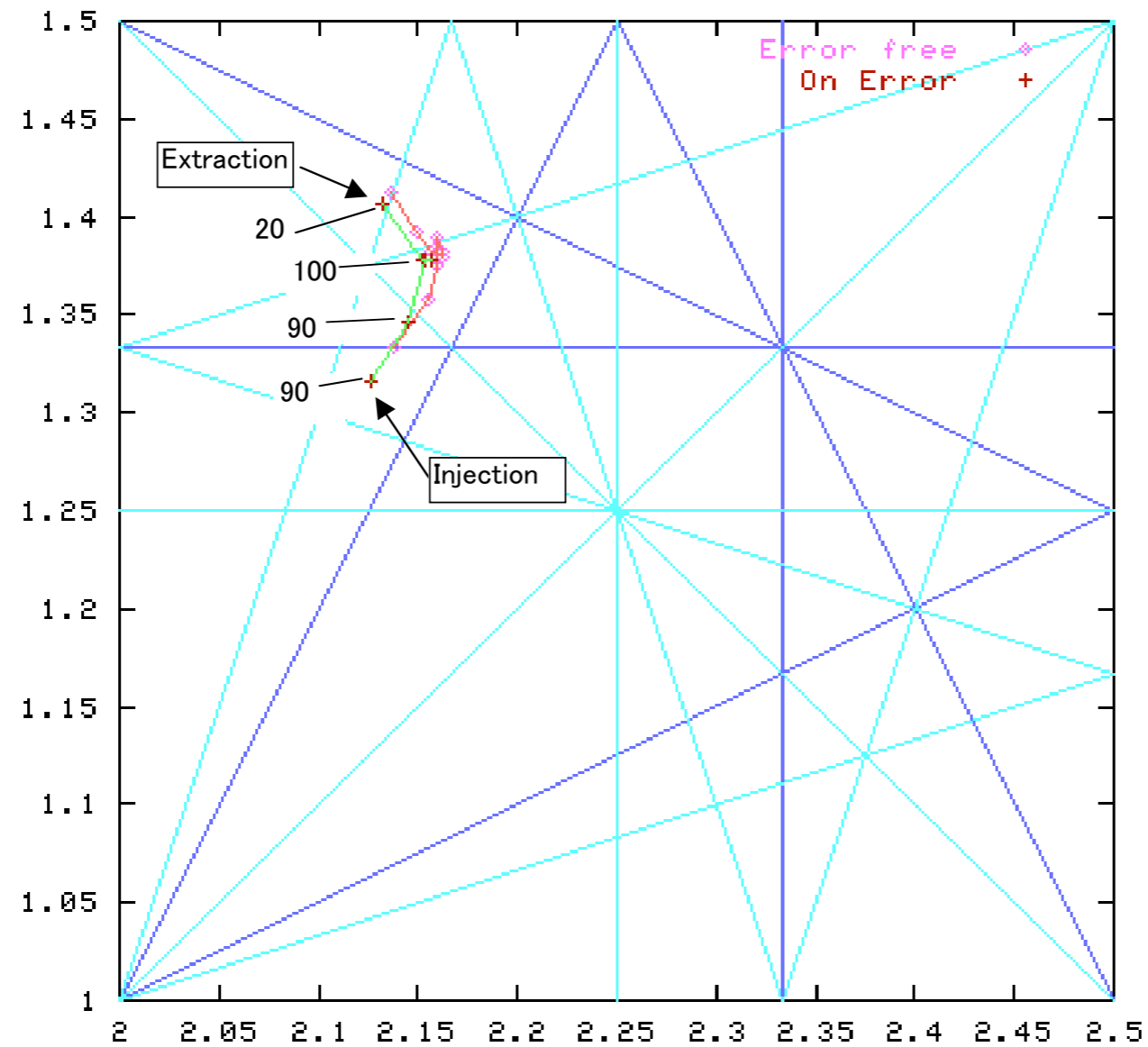

# Booster Magnets

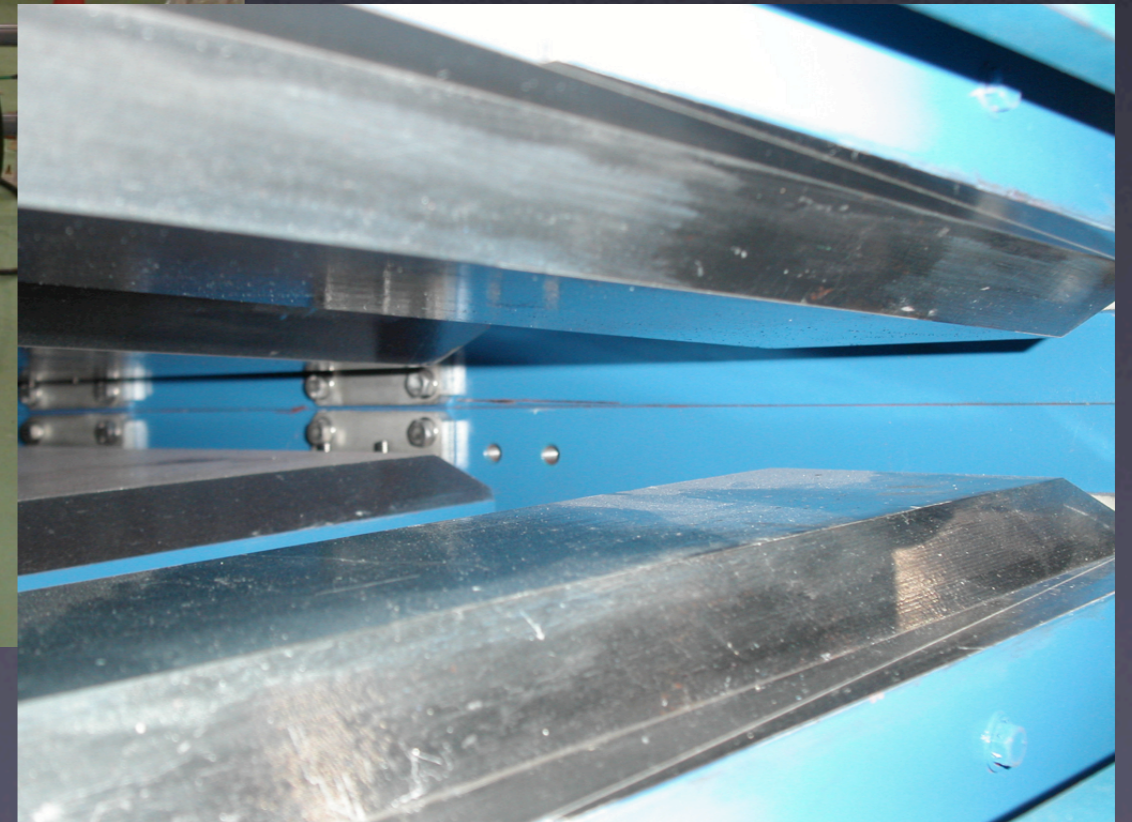
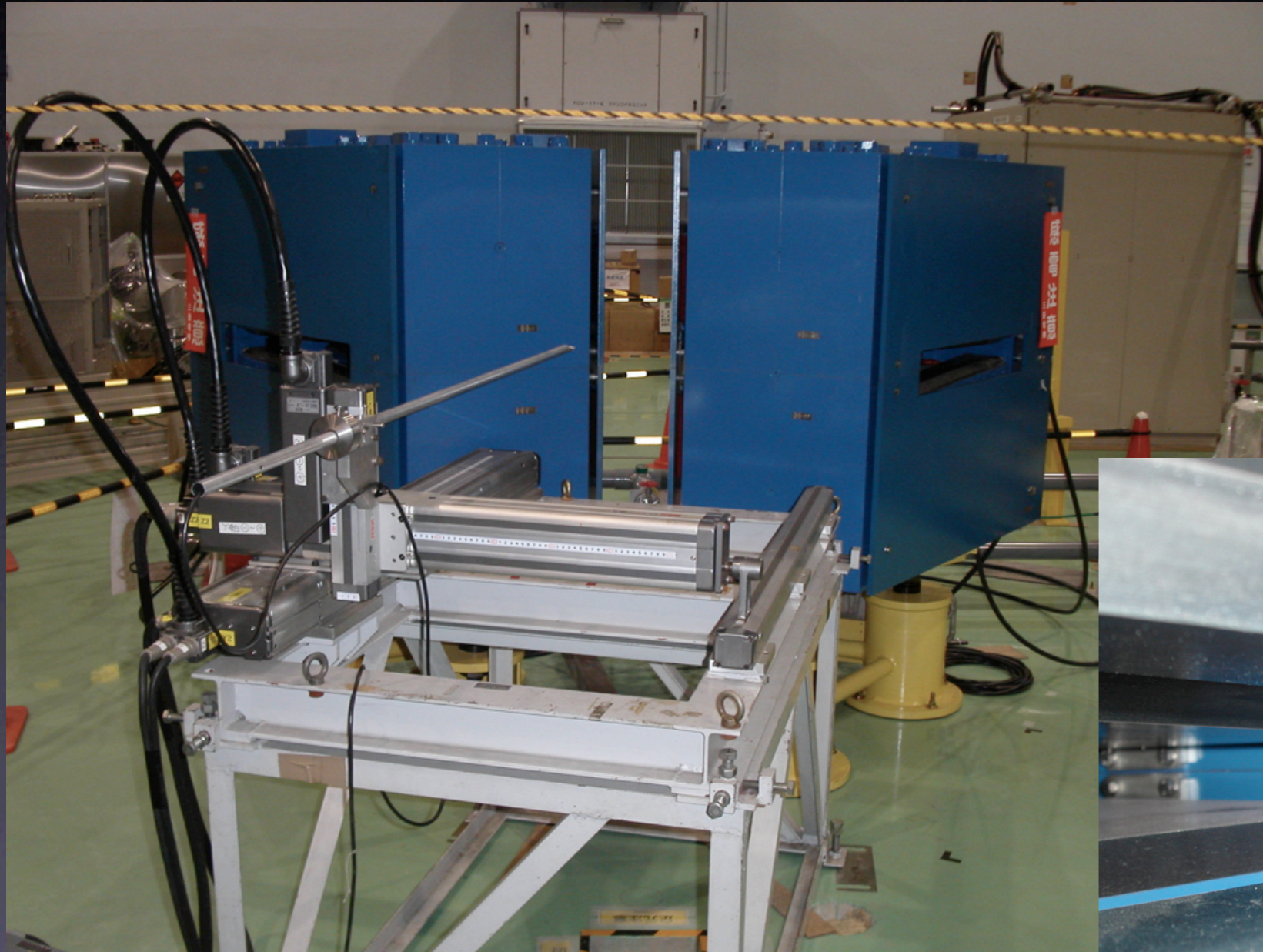

# Main Ring

Basically Identical to 150 MeV FFAG at KEK

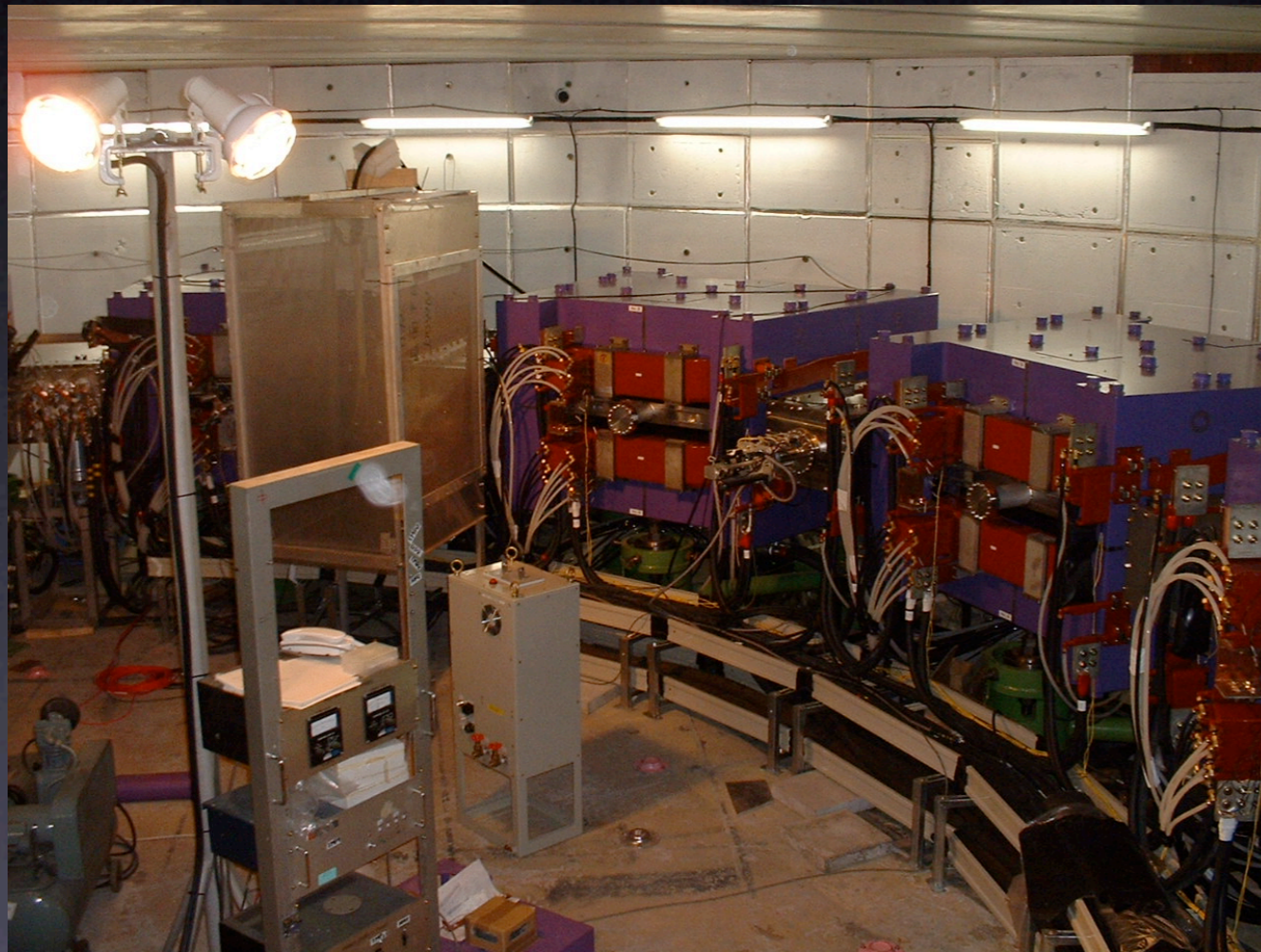

- Radial sector type
- Fixed  $k$  with pole shape
- RF acceleration

# Control System



Controlled  
Devices

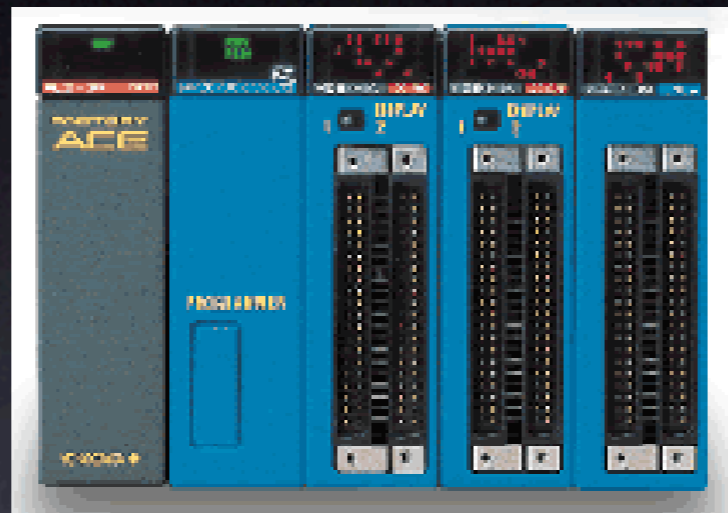

PLC

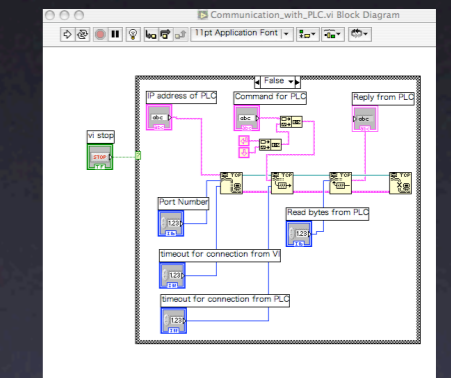

PC &  
LabView

Abstraction of Devices by PLC

# FFAG Room as of May 2005



Current Status: Have a look on Wednesday Tour!

# Acceleration Test of Injector without coils for variable $k$

- Without coils for variable  $k$  ( $E \sim 300$  keV)
- Beam interval = 1 sec
- Partial Core P.S. in operation

# Acceleration in Injector without coils for variable $k$

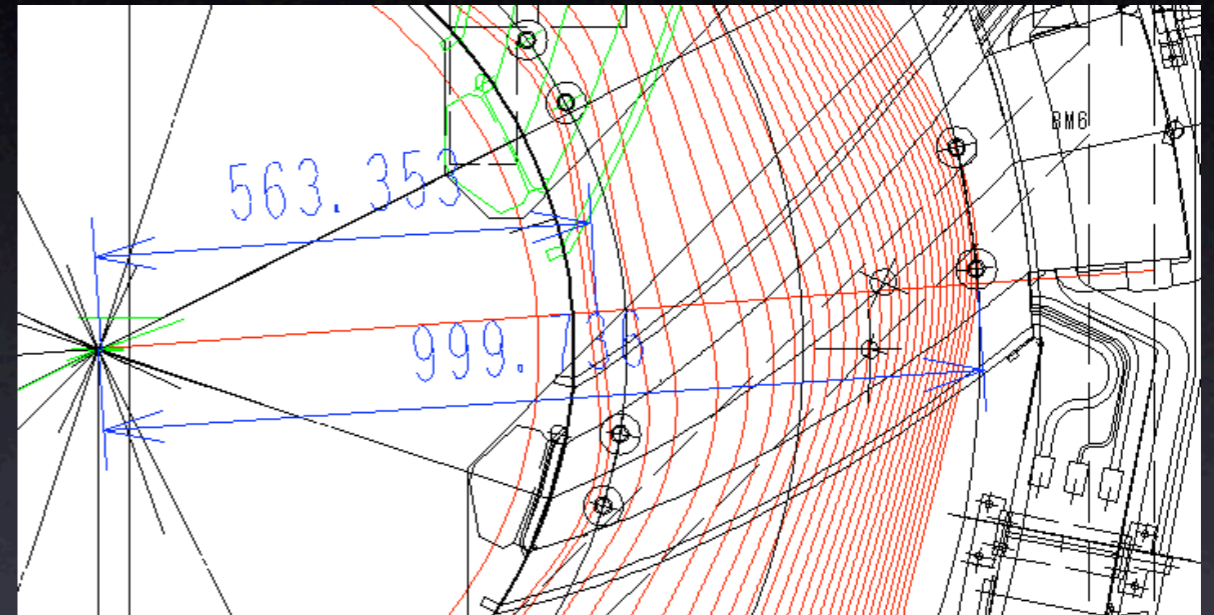
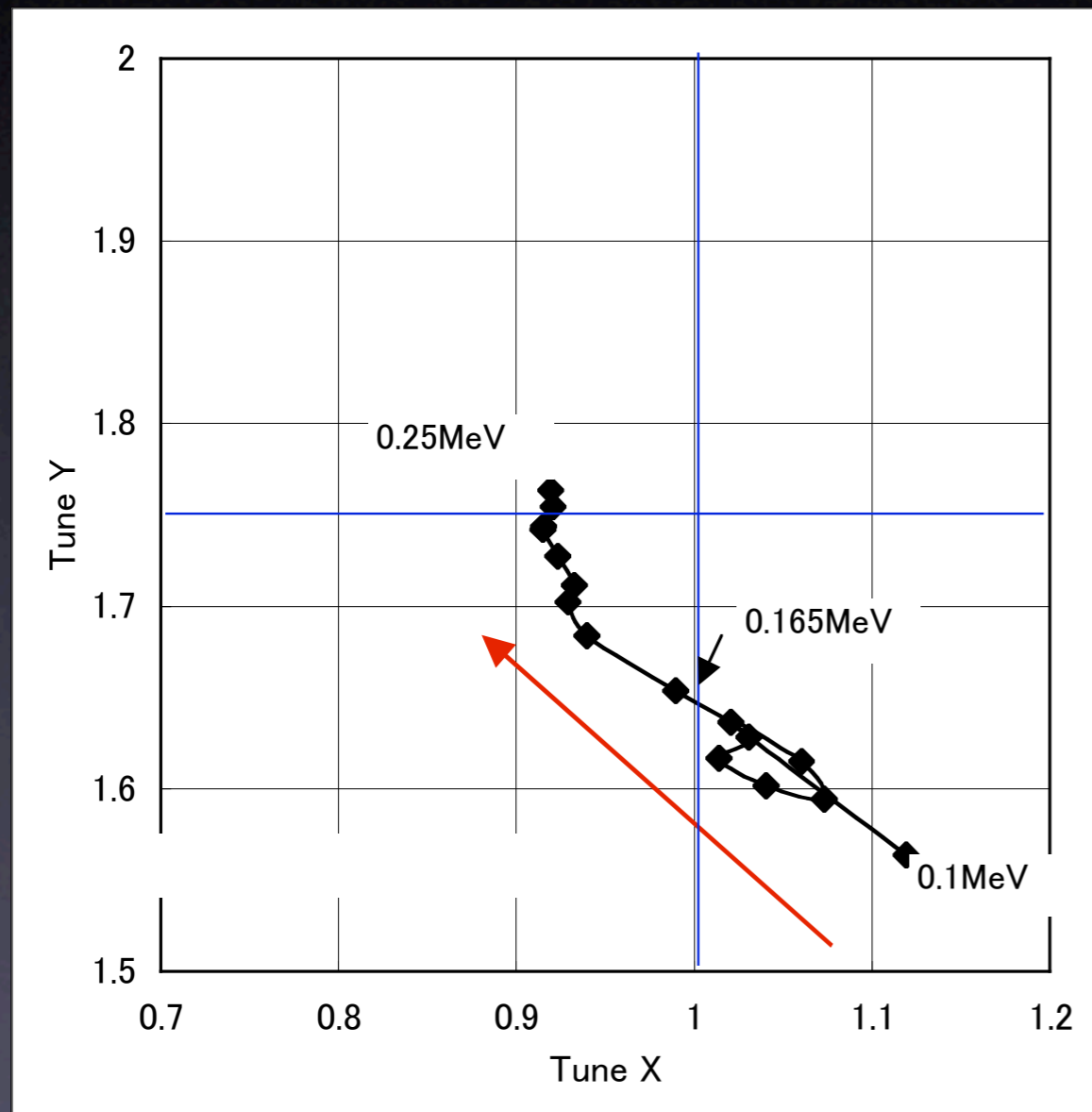

Acceleration up to  
 $E \sim 0.25 \text{ MeV}$   
Passing through  $v_x = 1$   
 $E \sim 0.165 \text{ MeV}$

# Tune vs Radius

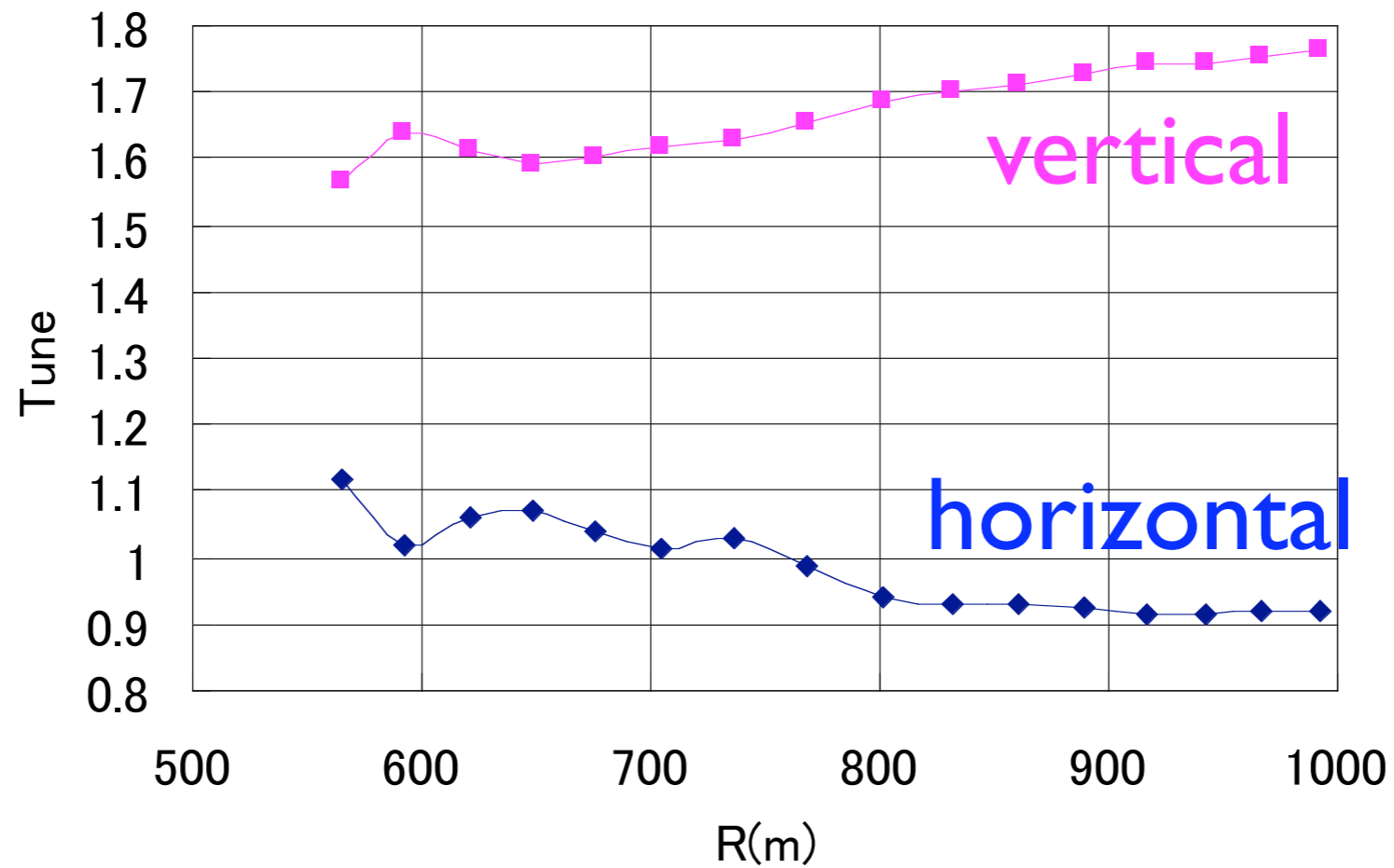

# Acceleration Pattern

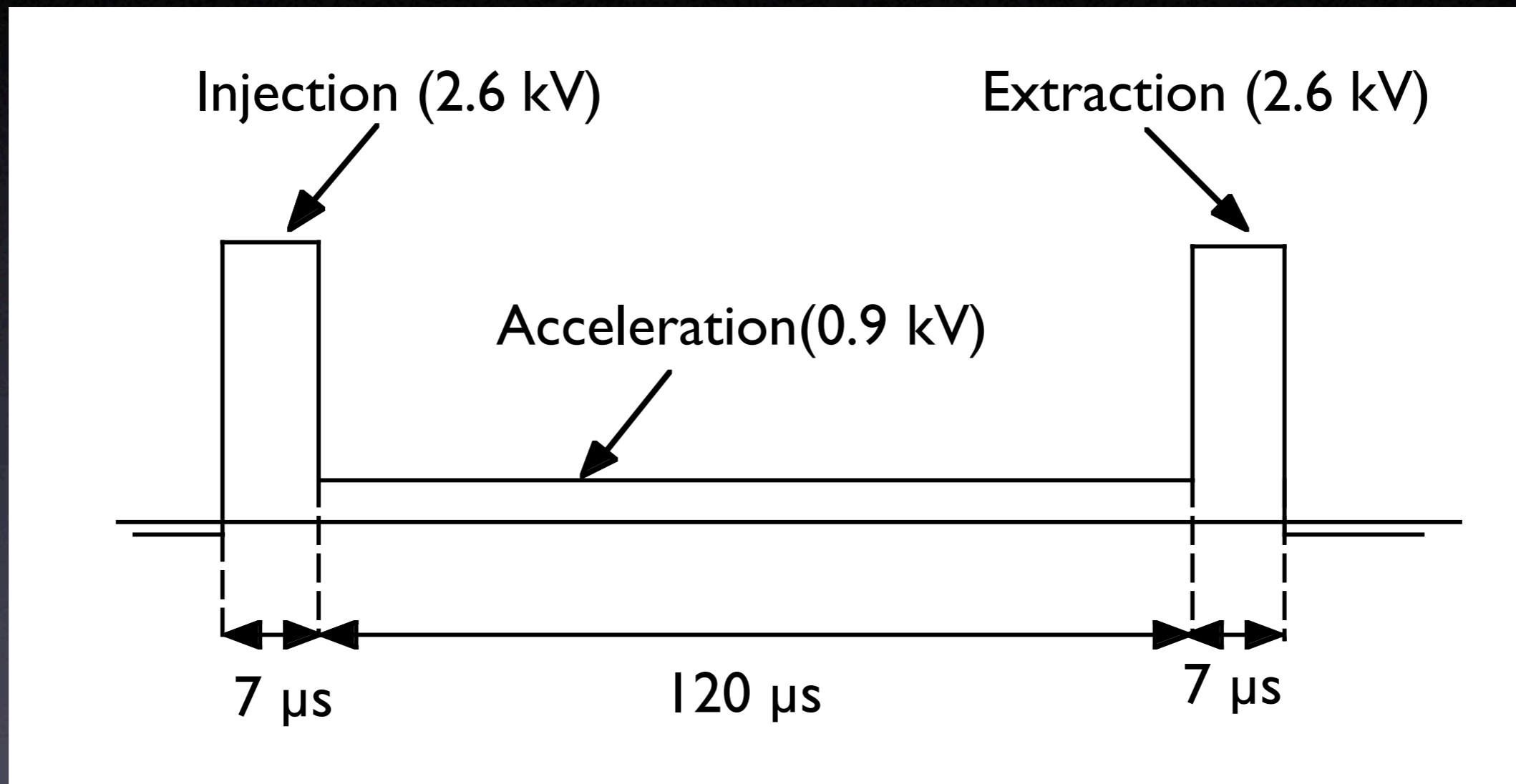

Repetition rate = 120 Hz  
Beam injection period = 1 sec.

# Acceleration Test

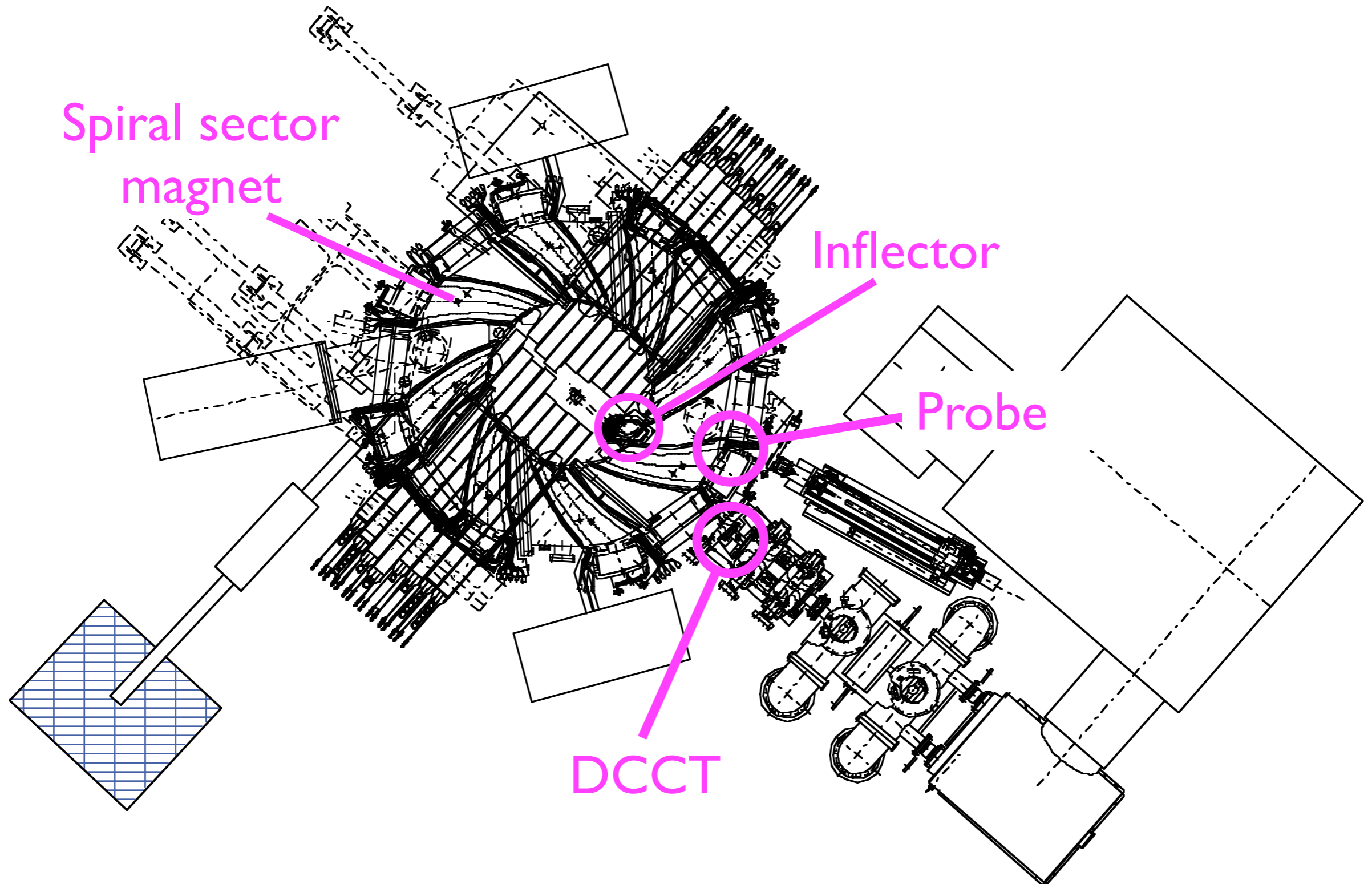

# 京大FFAGのイオンベータ誘導加速に成功

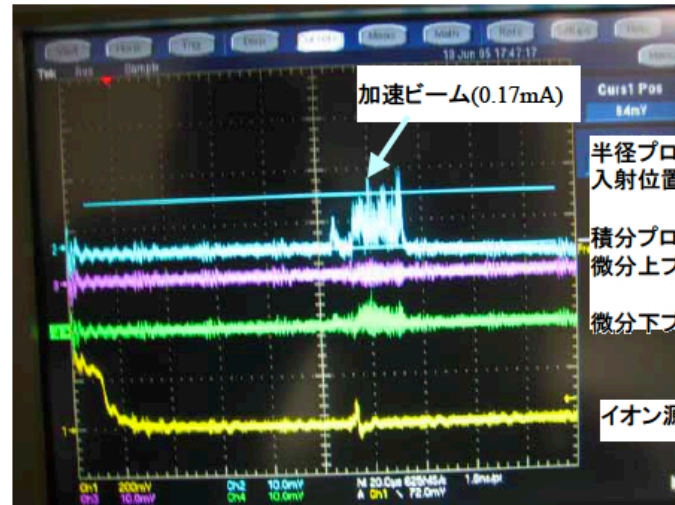

ビーム入射      加速(約120  $\mu$ s)

2005年6月13日(月)15時25分  
入射エネルギー100keV、加速エネルギー250keV、ビーム電流0.17mA

$$E_{\text{acc}} = 250 \text{ keV}$$

$$I = 0.17 \text{ mA}$$

@ Deflector Radius

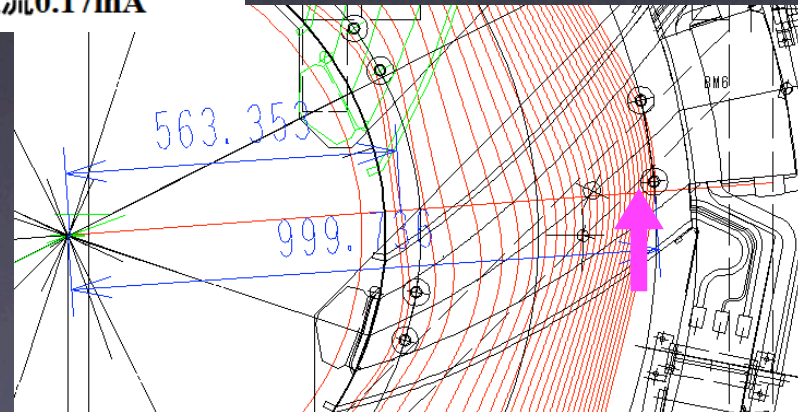

# Acceleration Test

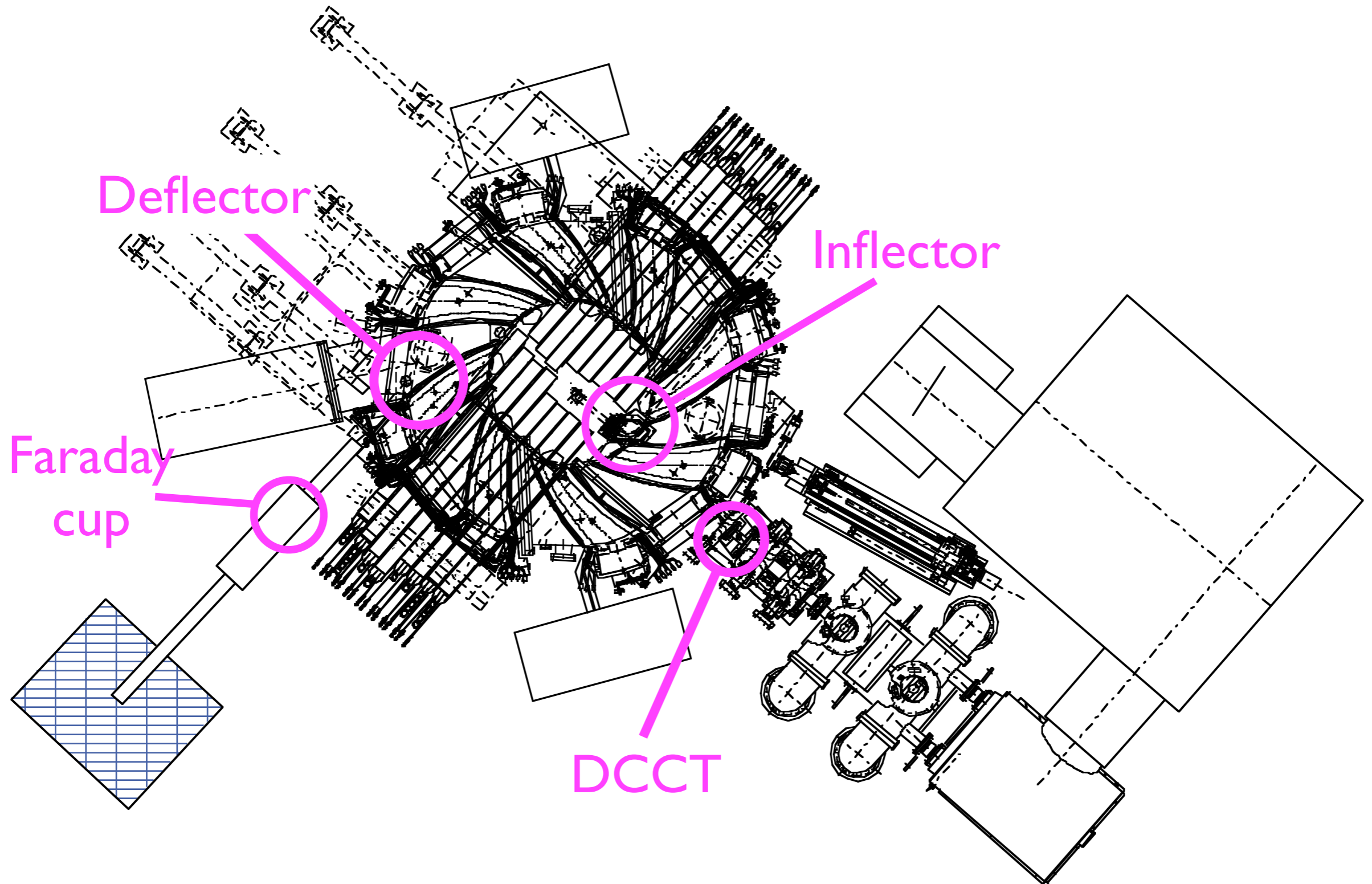

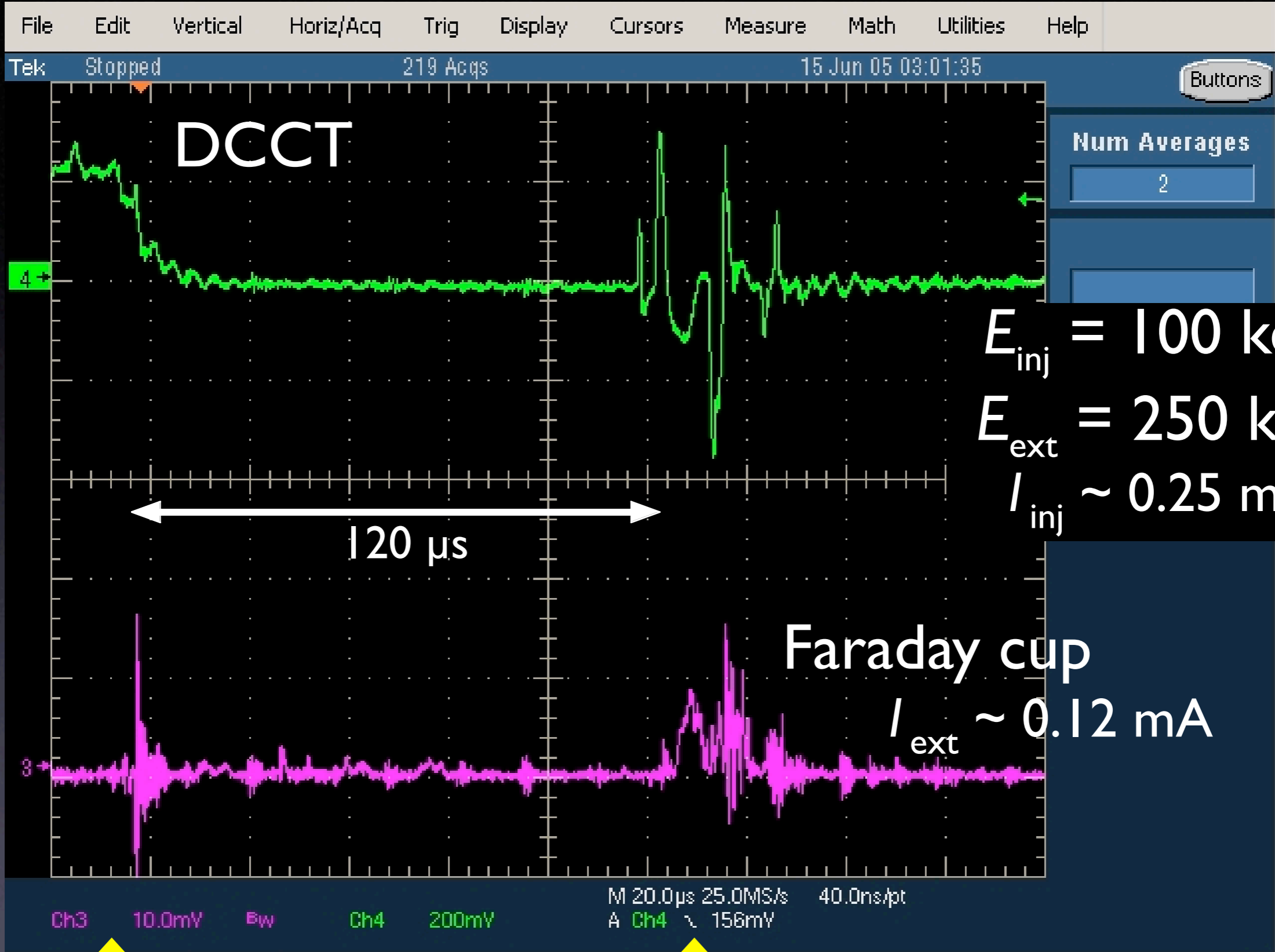

$E_{inj} = 100$  keV  
 $E_{ext} = 250$  keV  
 $I_{inj} \sim 0.25$  mA

$I_{ext} \sim 0.12$  mA

Injection

Extraction

# Schedule

- Test Operation of Injector  
within Two weeks
- First Beam from FFAG Complex  
Spring of 2006 ~
- ADS feasibility Study  
~ Summer of 2006