

Energy	250-500keV
Acceleration frequency	10kHz (Induction)
Beam Power	10kW
Outer diameter	1.1m

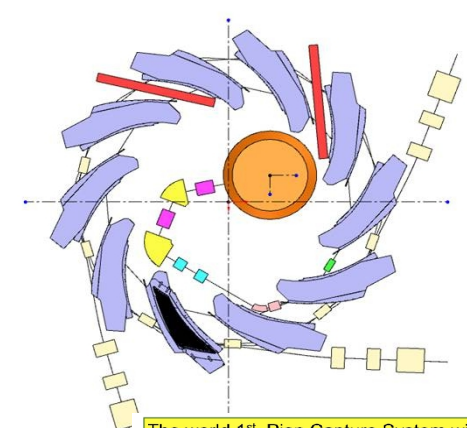

The world 1st Pion Capture System with SuMuSIC at RCNP, Osaka, JAPAN

Pion capture solenoid
Max. B_{sol}: 3.5 T

Pion beam transfer
Max. B_{beam}: 2.0 T
Max. B_{dipole}: 0.64 T



WSS proton beam line
392MeV, 1 μA
MuSIC is for the f...
The 1st beam test has been performed
The 2nd beam test will be in...

FFAG 2010

KURRI-Institute, Kyoto University, 28-31 Oct.

WORKSHOP SUMMARY

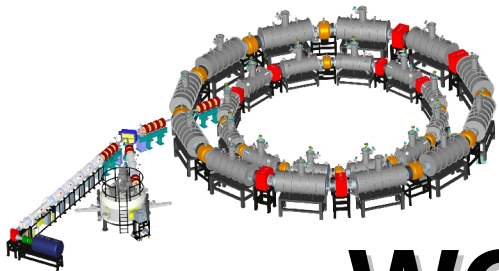

Developed five electrodes beam monitor

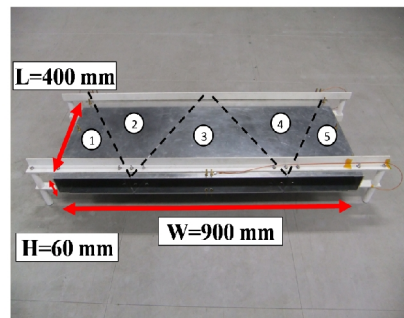

F. Méot, BNL

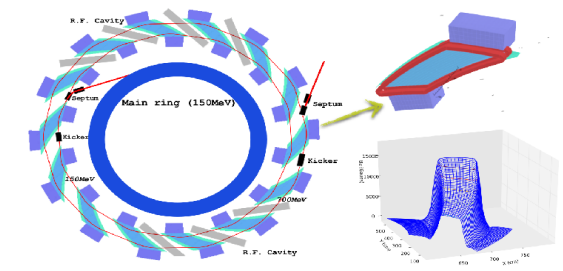

Schematic view of spiral FFAG ring (N=14)

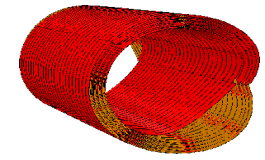
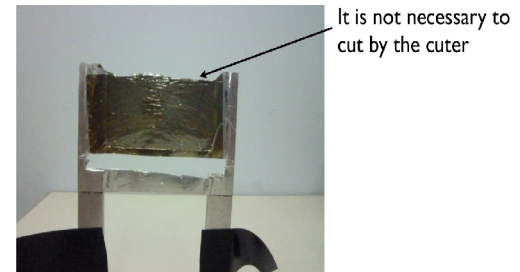

Thu, 9:10-9:40, 1st talk

EMMA: Design & Commissioning

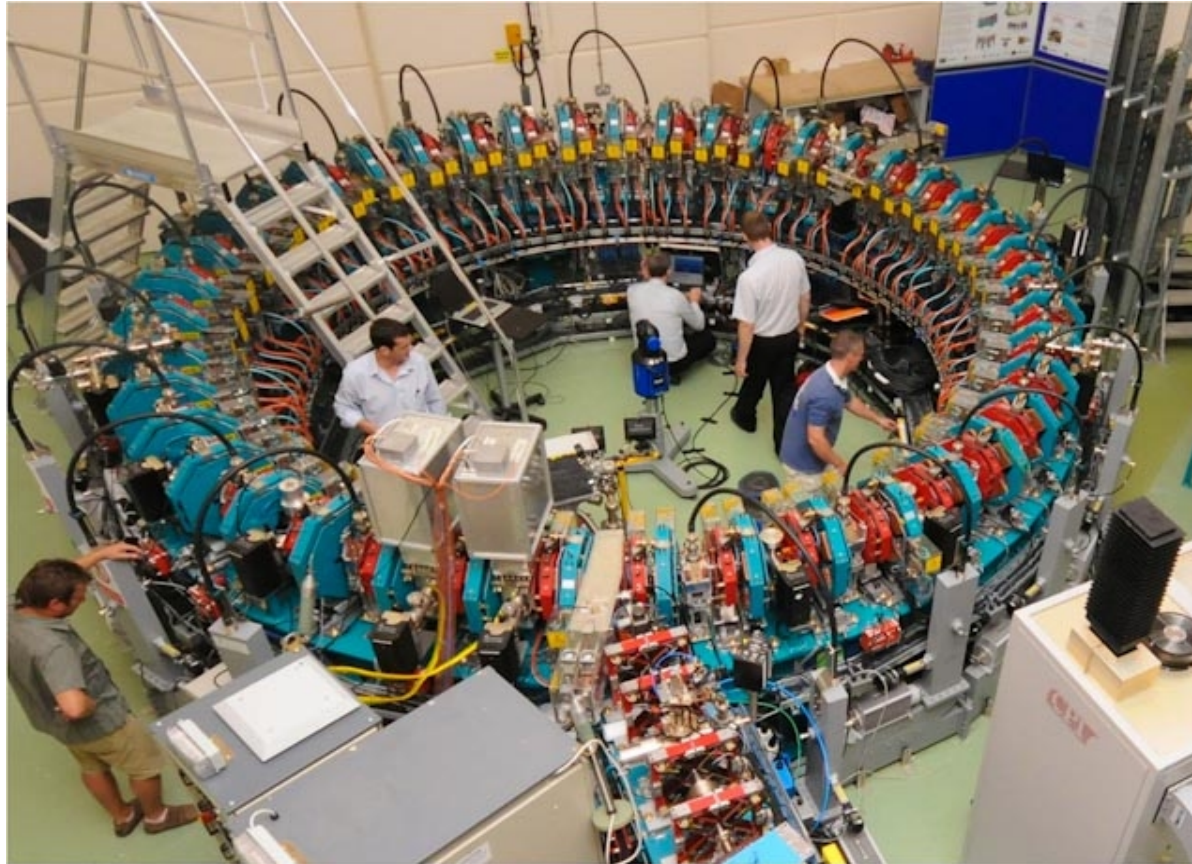

Bruno Muratori, DL

on behalf of the EMMA team,

STFC, ASTeC, Daresbury Laboratory & Cockcroft Institute

- EMMA design is an international effort, active collaboration from :
 - Brookhaven National Laboratory US
 - Cockcroft Institute UK
 - Fermi National Accelerator Laboratory US
 - John Adams Institute UK
 - LPSC, Grenoble France
 - Science & Technology Facilities Council UK
 - TRIUMF Canada
 - ...

Very good progress have been made

Design and construction phase of the project completed in **August 2010**

Injection / extraction work

Commissioning of the full ring is underway

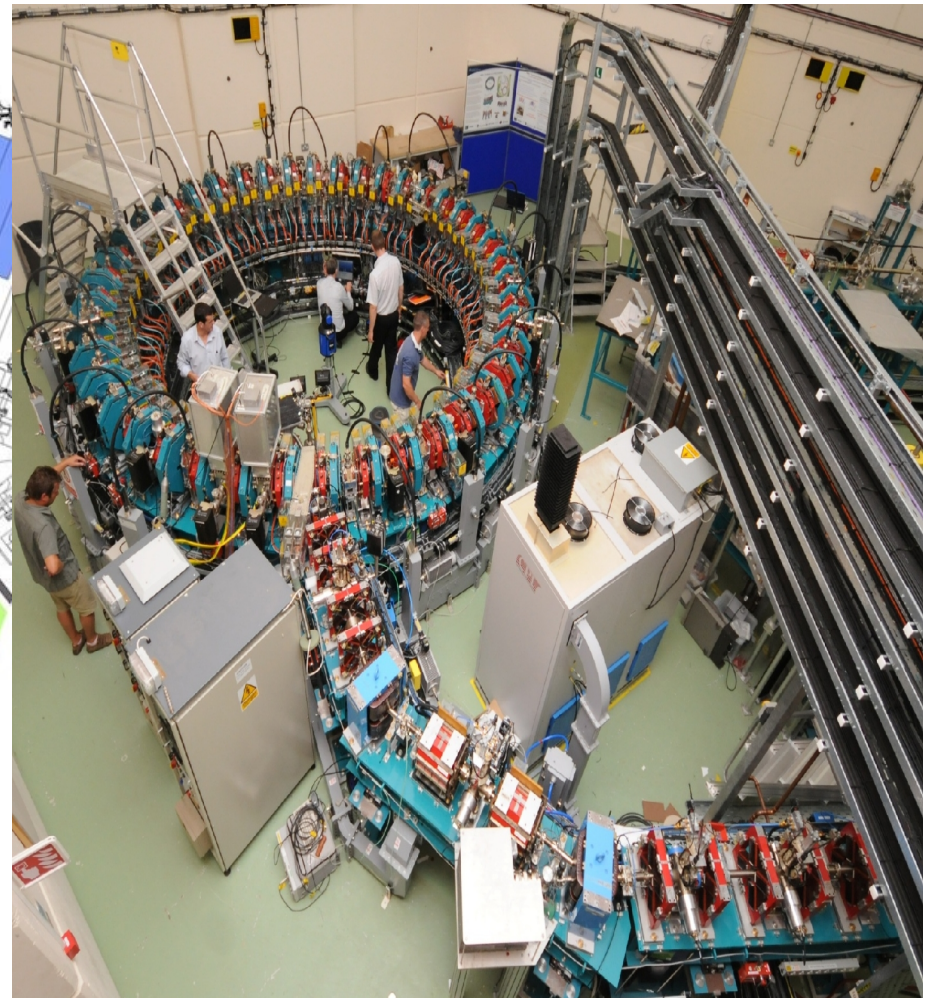
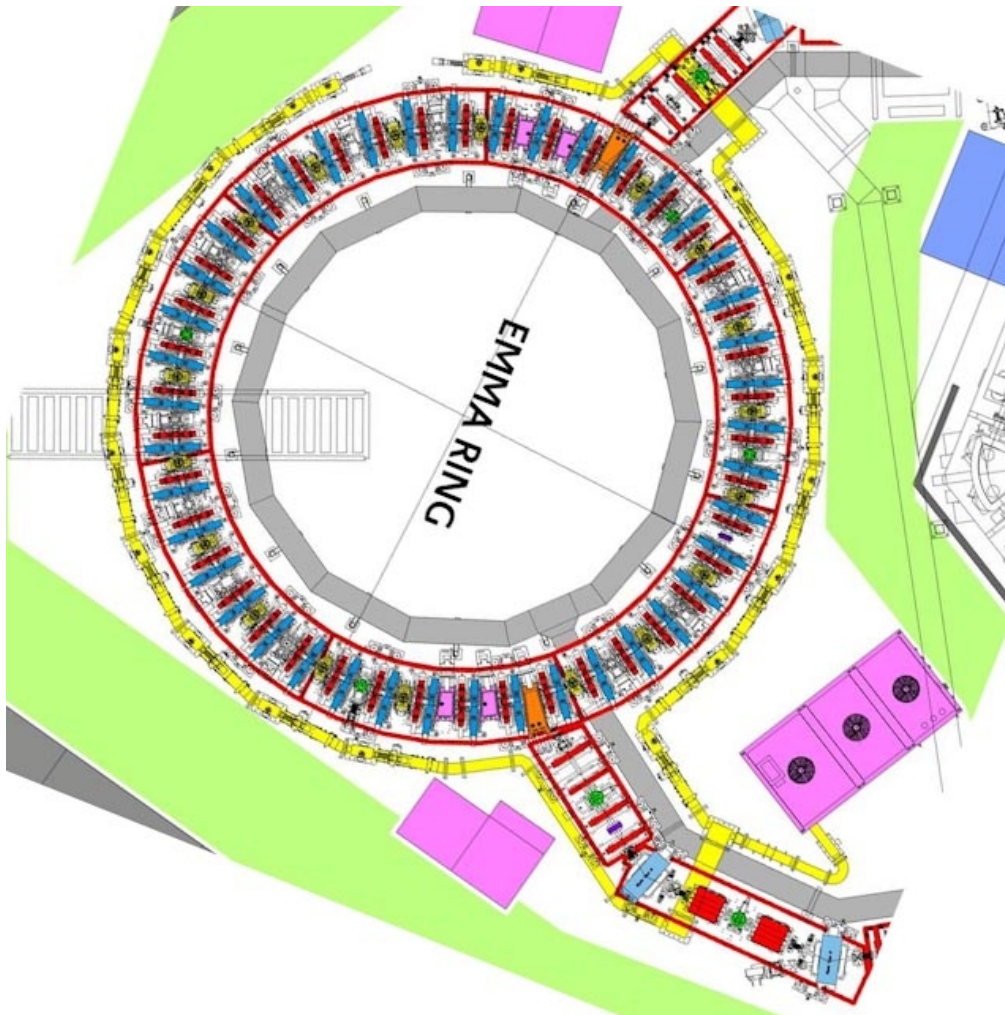

1000+ turns now routinely achieved (w/o RF)

Complete Ring

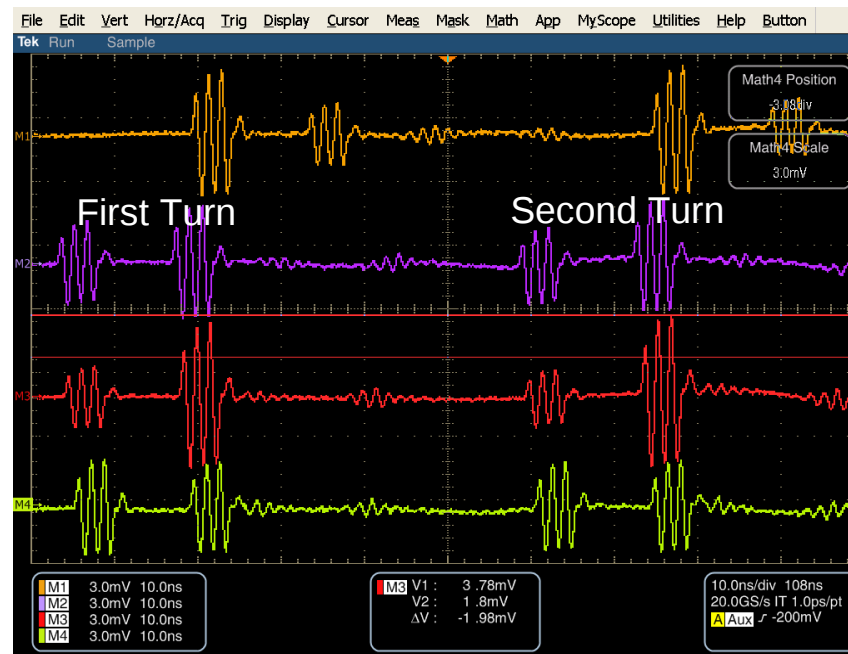
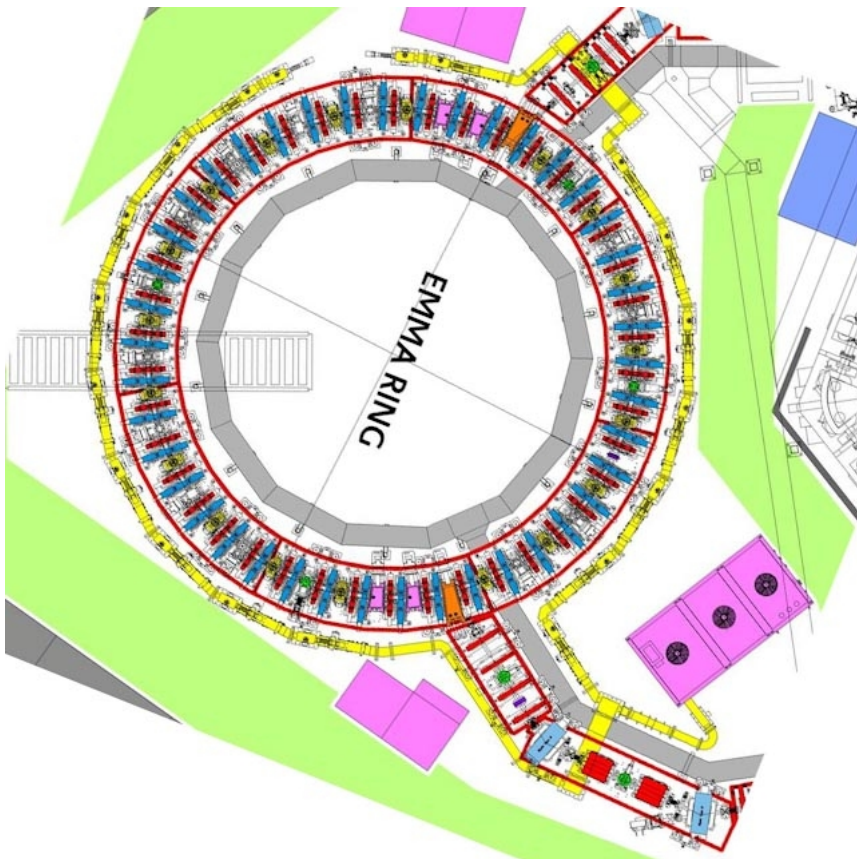

16th Aug 2010

Synchrotron oscillations have been seen

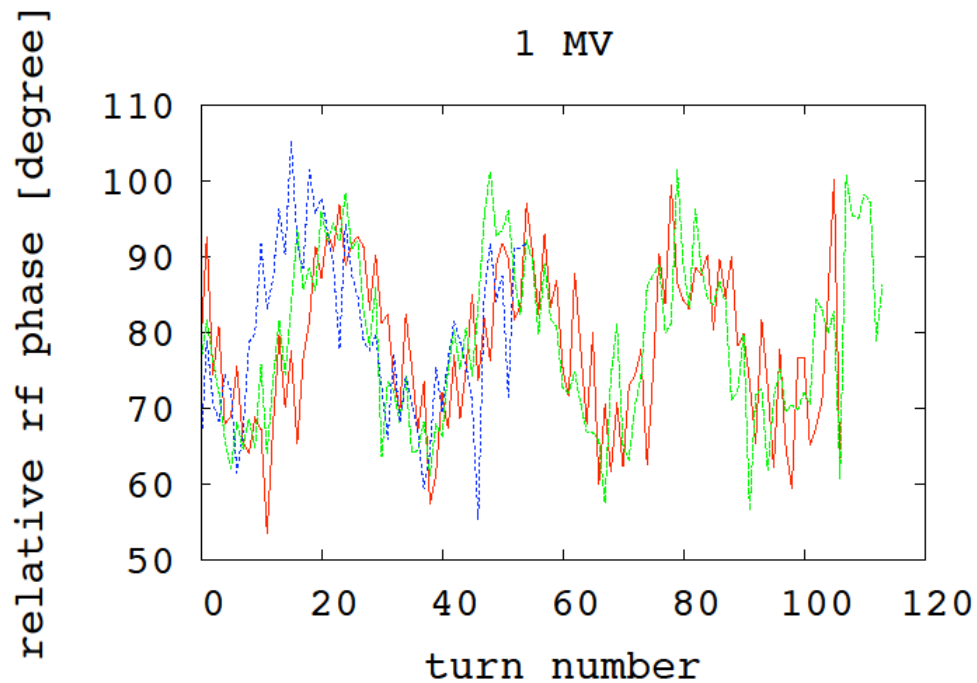

- Still have problem tuning 19 cavity phases
- RF buckets around transition momentum still separated
- Seen RF bucket & synchrotron oscillations inside it
- Going to adjust each cavity phase separately

Orbit correction can be performed

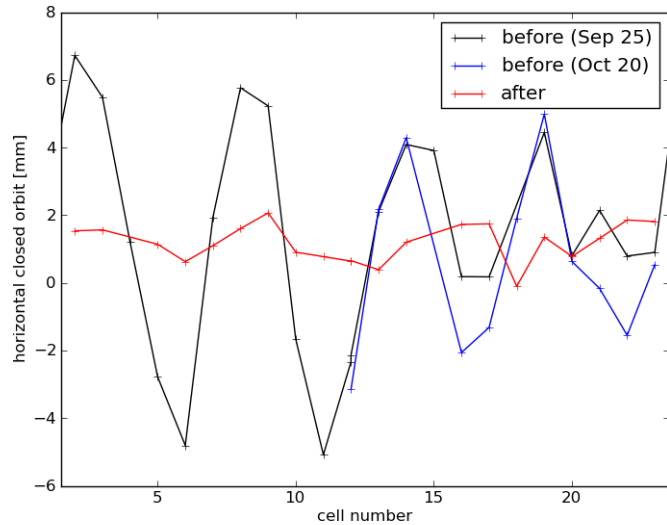

- Can do orbit correction
 - Can be done throughout the ring
 - Both vertically & horizontally
 - Usually done in first quadrant only

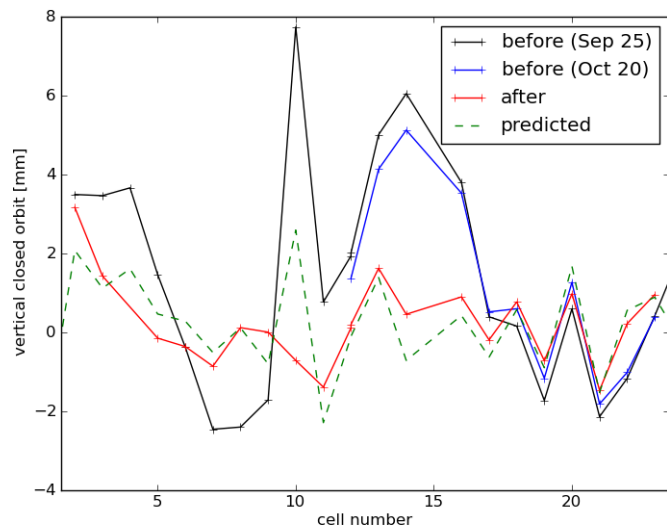

- This is almost always the same ...
- Have some misalignments in the ring
- Suspect some vertical correctors

Setting of cavity phases is understood

- To set the phases in the cavities we look at
 - Beam loading & power demand
 - Zero crest (both)
- Can be done for individual cavities and overall

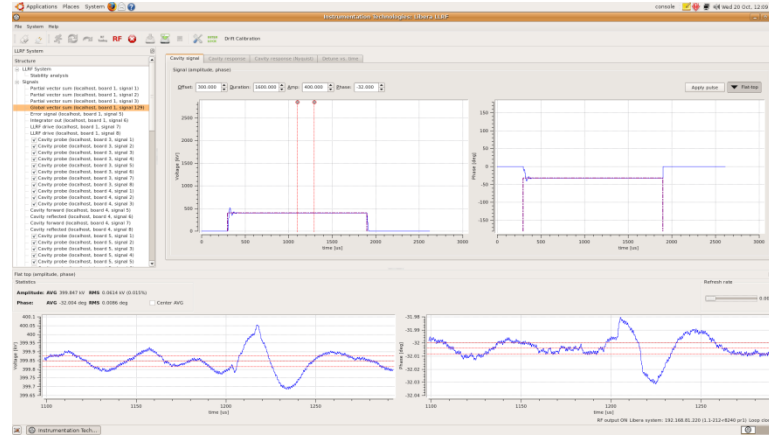
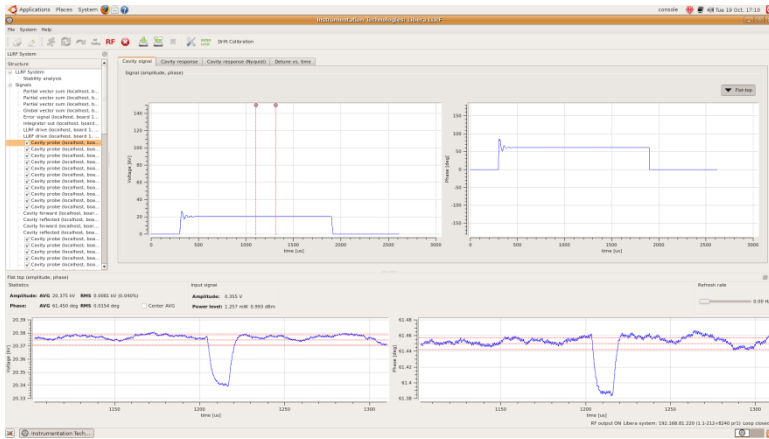

Next Steps

- **Carry on commissioning**
Are just about to accelerate...

Characterise Beam Dynamics

- Tunes and ToF fn of E ~ 1MeV steps
- Tune accelerator to match required lattice

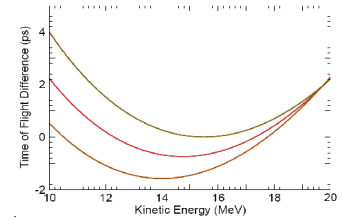
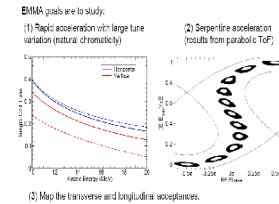

- **Perform the “EMMA Experiment”**

- Acceleration 10 – 20 MeV
- Resonance crossing
- Detailed bench marking with codes
- Scan aperture in phase space (both longitudinally and transversely)
- Benchmark measured dynamic aperture with and without acceleration against the simulations

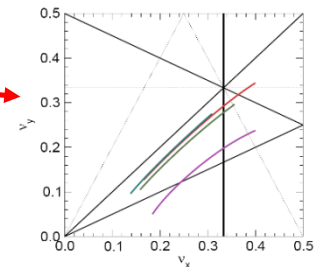
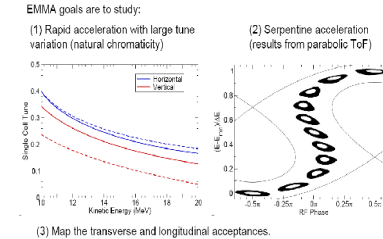

- We are now in crucial time for EMMA results
...
- Operations start again in 2011 - **all interested let Bruno know**
- Any ideas for upgrades / new experiments very welcome - **e-mail Bruno as the time to ask is now** - Bruno will share list so far

Thu, 9:40-10:10, 2nd talk

PAMELA Overview

Suzie Sheehy, Univ. Oxford

PAMELA: Particle Accelerator for MEDical Applications

Aim: “to design a prototype proton/carbon ion ns-FFAG accelerator for charged particle therapy”

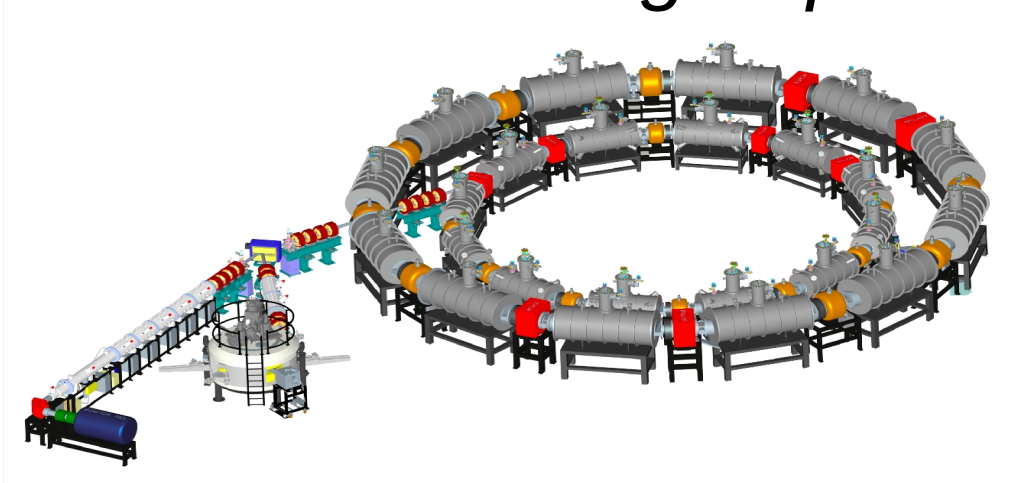

Collaboration in UK

Oxford (JAI, Gray, PTCRI)

John Cobb , Bleddyn Jones, Ken Peach,
Suzie Sheehy, Holger Witte, Takeichiro
Yokoi, Mark Hill, Boris Vojnovic + others

Brunel University

Richard Fenning, Akram Khan

Imperial College London

Morteza Aslaninajad, Matt Easton,
Jaroslaw Pasternak, Juergen Pozimski

STFC/ASTeC/RAL, STFC/DL

Elwyn Baynham, Neil Bliss, Rob
Edgecock, Ian Gardner, David Kelliher,
Neil Marks, Shinji Machida, Peter
McIntosh, Chris Prior, Susan Smith

Lattice Design



Injection



Extraction



Magnet Design



Medical Requirements



RF



Gantry



Beam transport



Front end



Injection line



Ion sources



Engineering solutions



Every part of the PAMELA facility has now been designed (at least conceptually) :

- injector and ion sources
- RFQ and linac
- ring lattice
- and more...

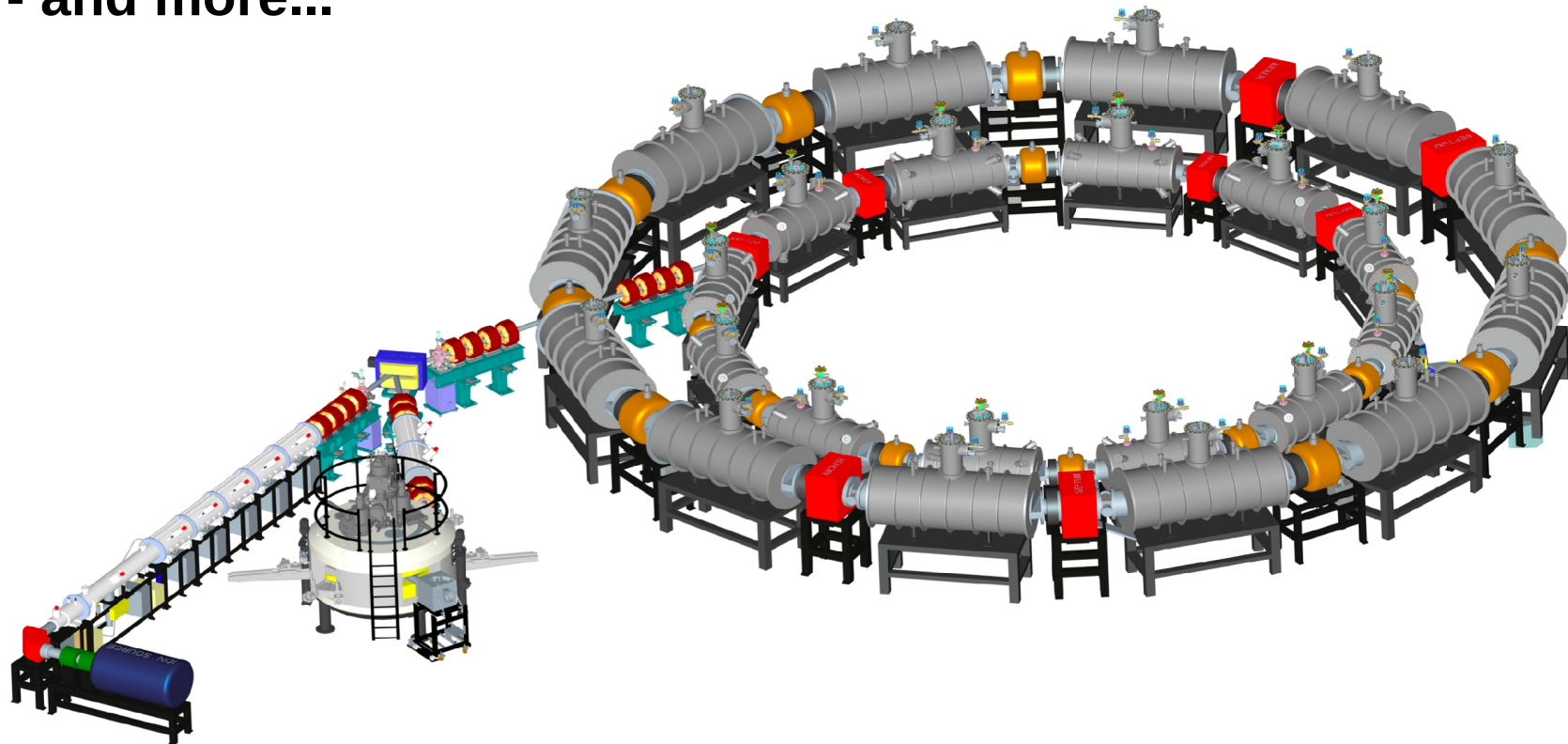
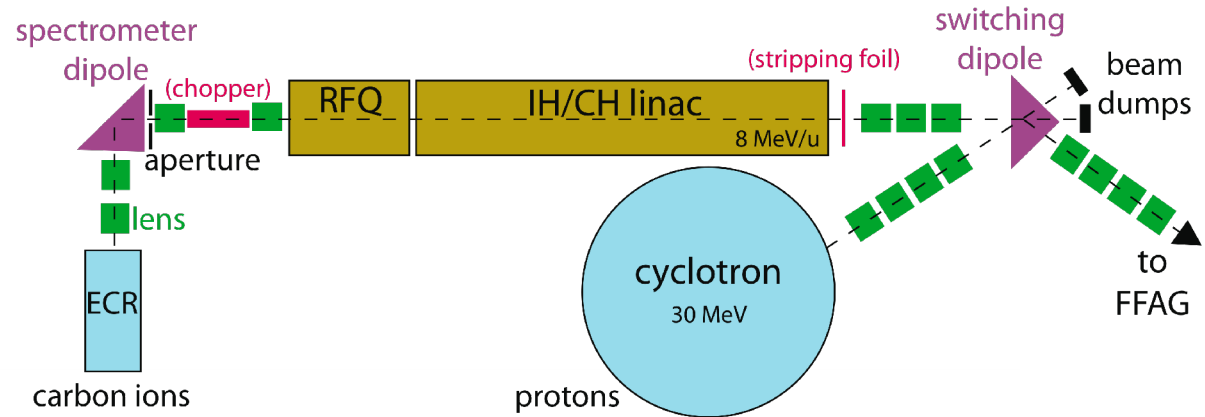

A lot of progress has been made in the engineering design of the magnets :

- main ring magnet
- kicker, septum

Main ring magnet, approach:

Combines multipoles in double-helix coils

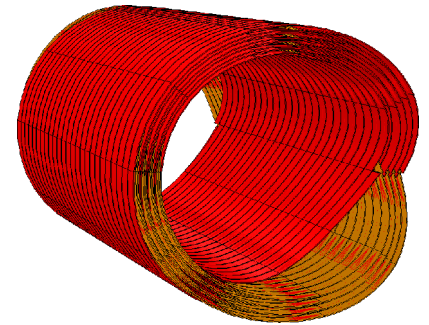

56.7% Dipole
30.6% Quadrupole
9.7% Sextupole
2.5% Octupole
0.5% Decapole

3D model kicker for proton lattice

- Arbitrary ferrite ($B_{\text{sat}}=300$ mT)
- Length: 1 m
- Current sheets: 1 mm thickness
- Current densities:
 - Carbon: 167 A/mm²
 - Proton: 55.55 A/mm²
- Magnetic Energy 16/150 J

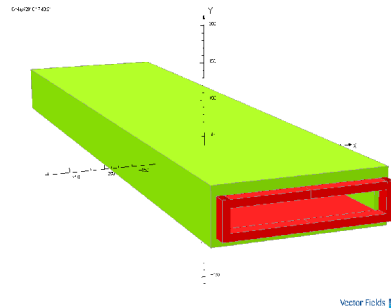
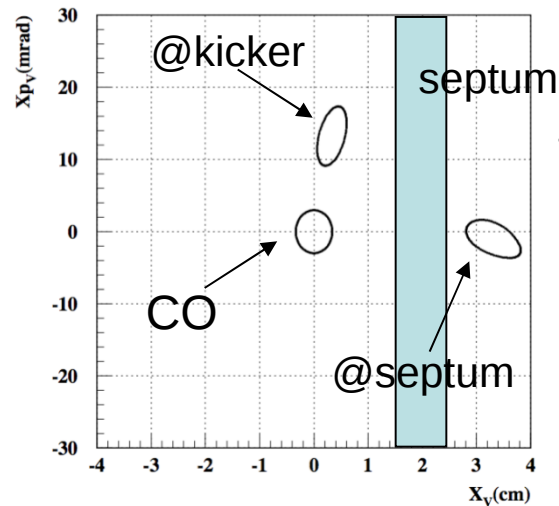
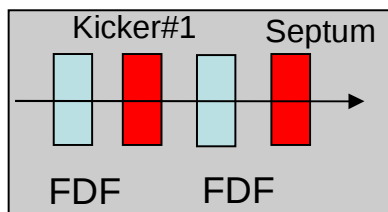

3D field map tracking yields very encouraging results, it is able to reproduce the tune-flattened lattice.

Before adjustment of multipoles

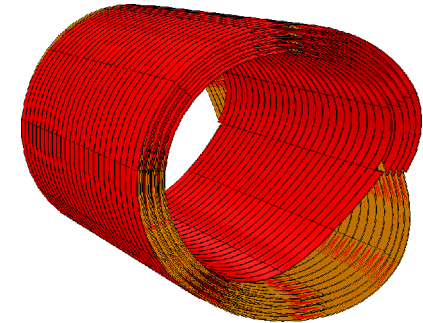
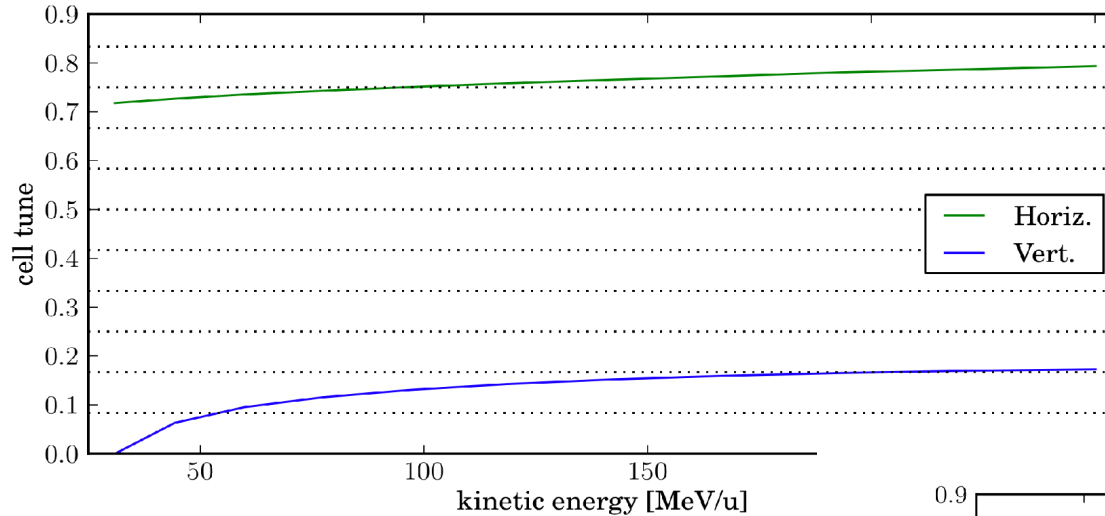

Adjusted tunes

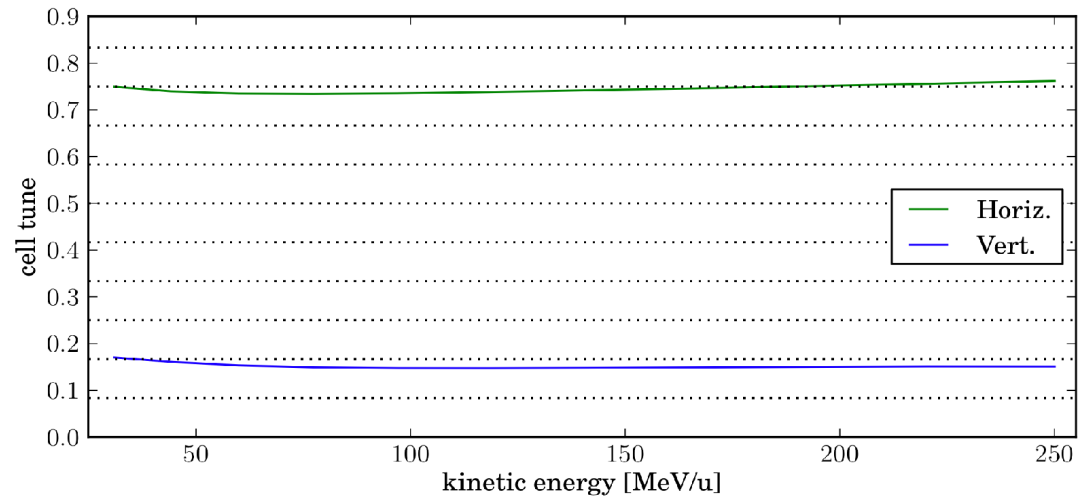

- Tracking: Unwanted field components
 - Patent Nov. 2009
- 3D field maps have been tracked in ZGOUBI.

Some prototyping is underway :

Ex. : proof-of-principle of the main ring magnet

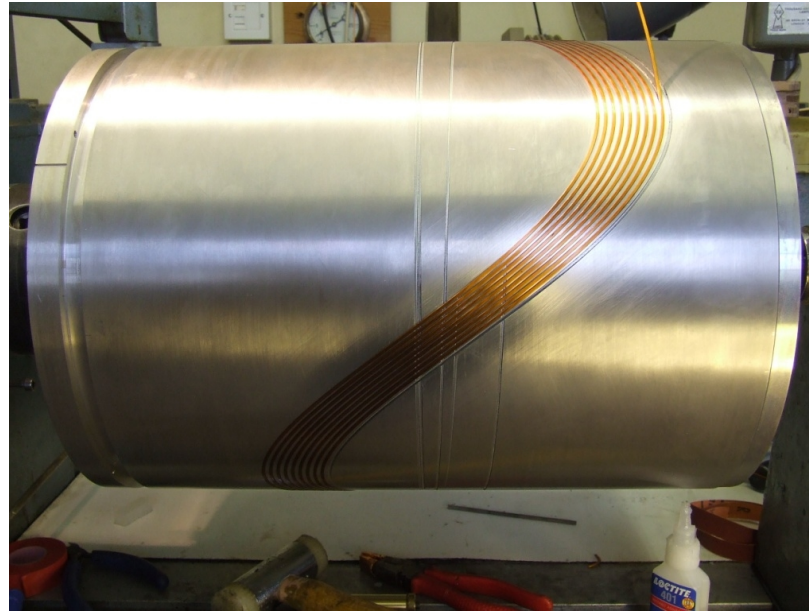

Much more is needed...

Where are we now ?

- **Final Design Review was October 4-7th 2010, Oxford**
- **Final design report being written (due January 2011)**
- **Prototyping is needed :**
 - Main ring magnets, kicker and septum magnets
 - RF
 - Ion source
- **Further understanding is needed in optimising treatment and radiobiology issues**
- **Funds/collaborators are sought!**

Thu, 10:10-10:40, 3rd talk
Yoshihiro Ishi, KURRI

**PRESENT STATUS AND FUTURE OF
FFAGS AT KURRI
AND
THE FIRST ADSR EXPERIMENT**

Y.Ishi, M.Inoue, Y.Kuriyama, Y.Mori, T.Uesugi, Kyoto University
Research Reactor Institute, Osaka, Japan
JB.Lagrange, T.Planche, M.Takashima, E.Yamakawa, Graduate
School of Engineering, Kyoto University, Kyoto, Japan
H.Imazu, K.Okabe, I.Sakai, Y.Takahoko,
Fukui University, Fukui, Japan

ADSR Studies in KURRI

Purpose

- The main purpose of this R&D is a basic feasibility evaluation of ADSR as an energy production device.

KUCA

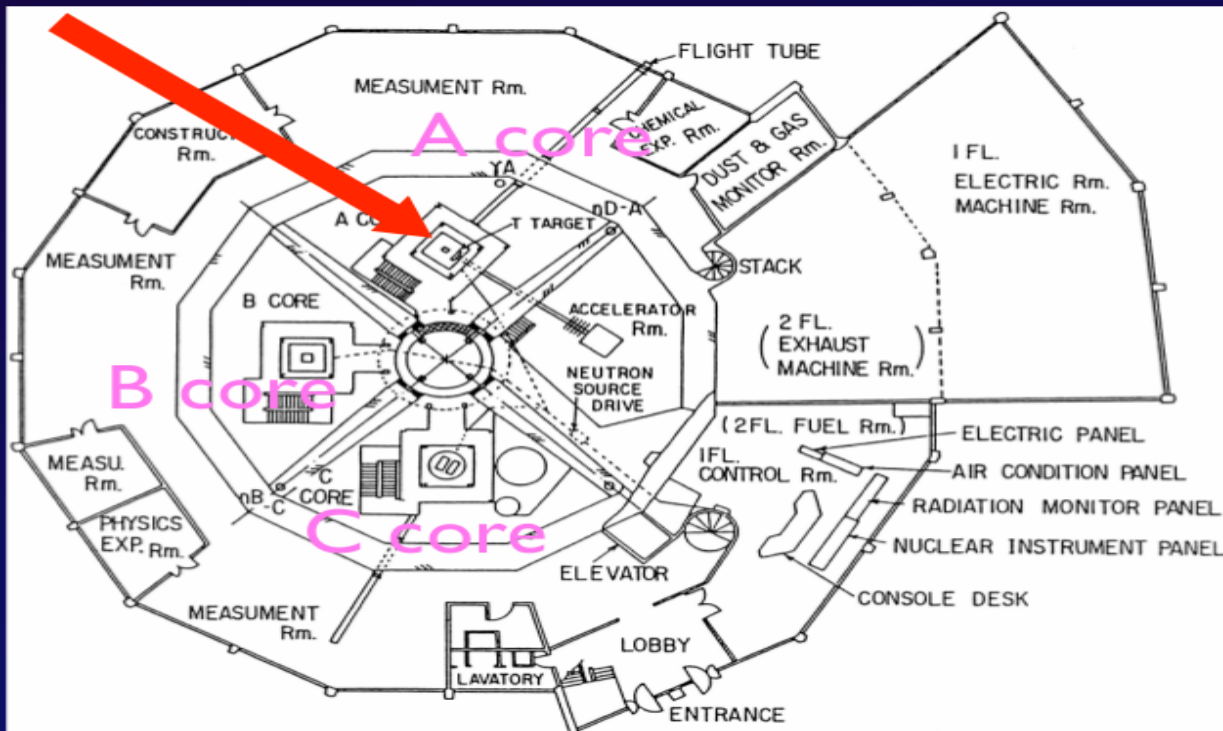

◆ KUCA Configurations

- 3 critical assemblies :
 - i. A & B cores
Polyethylene Mod./
Ref.
 - ii. C core
H₂O Mod./Ref.
- 2 accelerators :
 - i. Cockcroft-walton type
(D,T) reaction
14 MeV neutrons
 - ii. FFAG type
100 MeV protons

KURRI-FFAG complex

KUCA

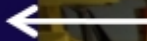

Main Ring

Booster

Injector

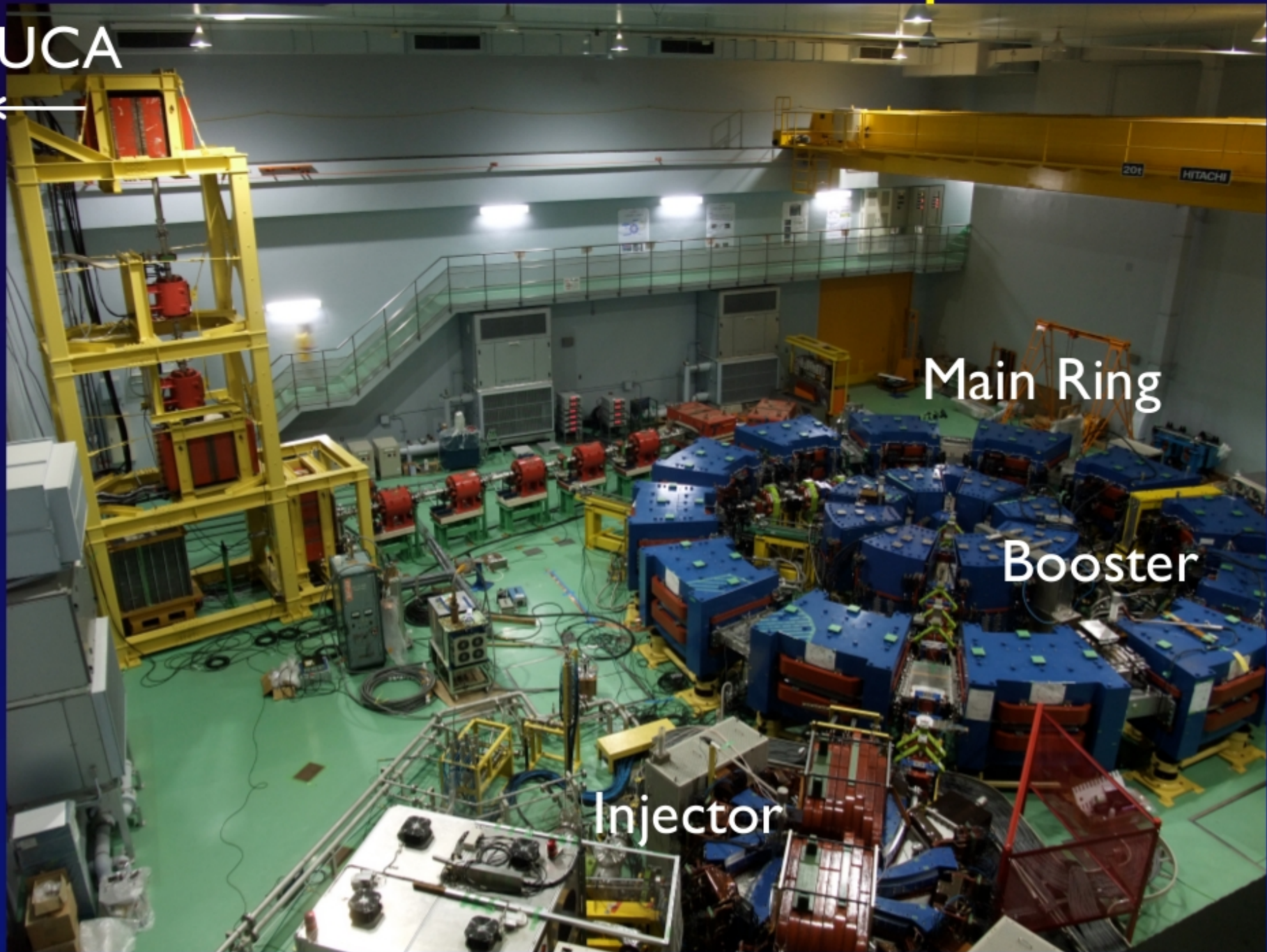

March 2009 : World's first ADS-Reactor experiment

ADSR Experiment Setup

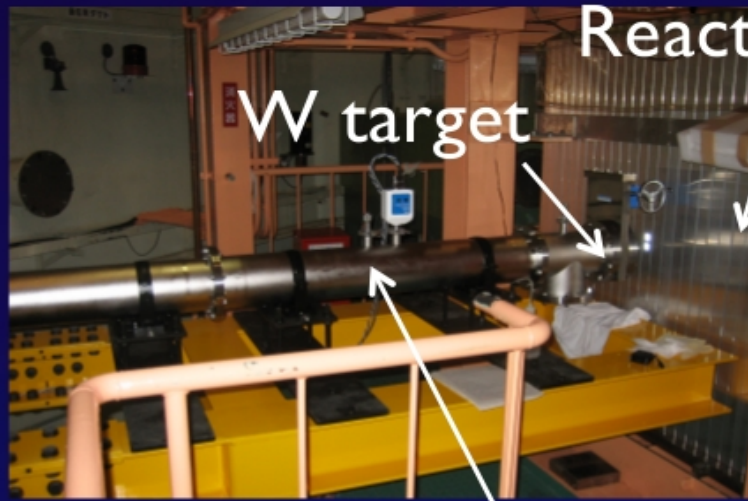

Beam transport line

◆ Conditions

- FFAG Accelerator :
100 MeV Protons
30 Hz repetition rate
~a few pA intensity
Tungsten target
(80mm diameter,
10mm thickness)

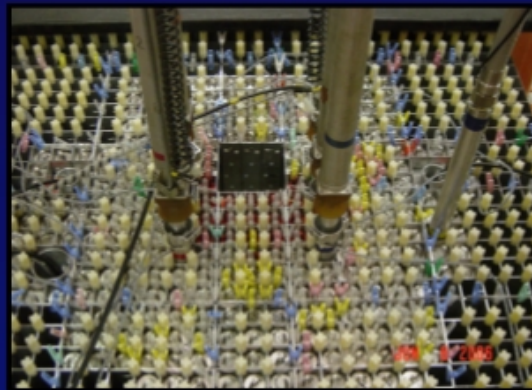

Subcritical fuel system

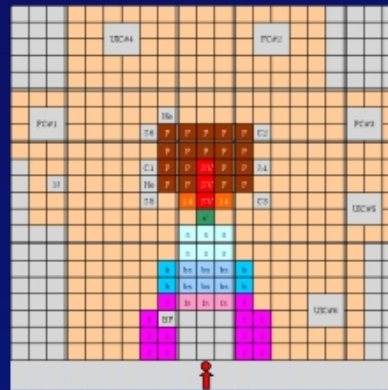

- KUCA A-Core :
93% enriched uranium
Polyethylene moderator/reflector
C1~C3 control rods fully inserted

Future Plans

Recently in KURRI, a high intensity pulsed neutron source is desired not only for ADSR studies but for research using high intensity neutrons.

Using FFAG system as a proton driver for the neutron source, two major upgrade paths are considered:

- the intensity enhancement by changing the injector system;
- the energy upgrade up to 700MeV to enlarge the number of spallation neutrons.

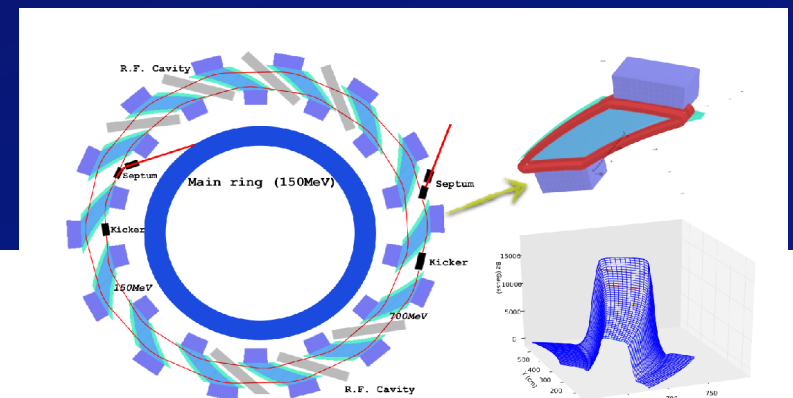
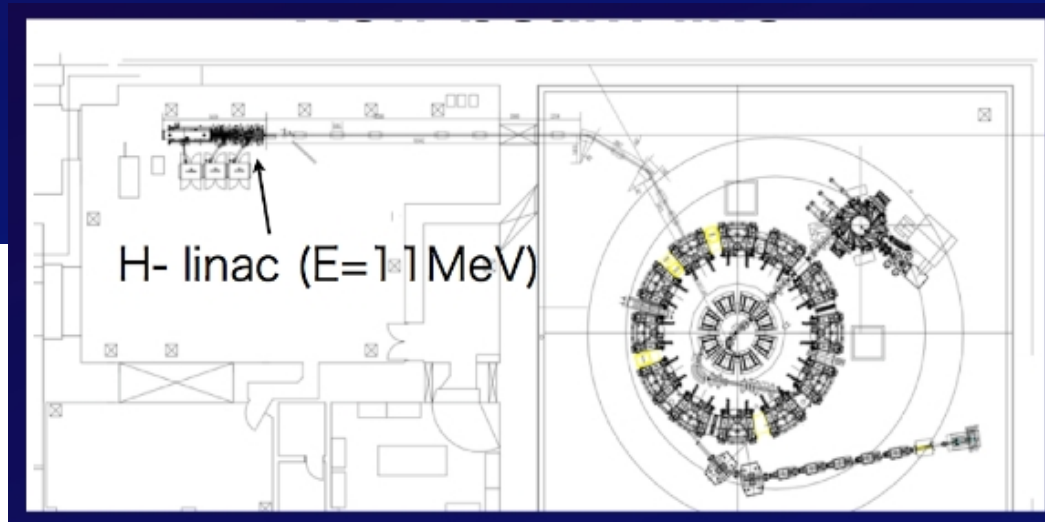

Schematic view of spiral FFAG ring (N=14)

Thu, 11:00-11:30, 4th talk
MuSIC, COMET, and PRISM
Akira Sato, Osaka Univ.

It is recognized that there is strong potential of

Technological Synergies

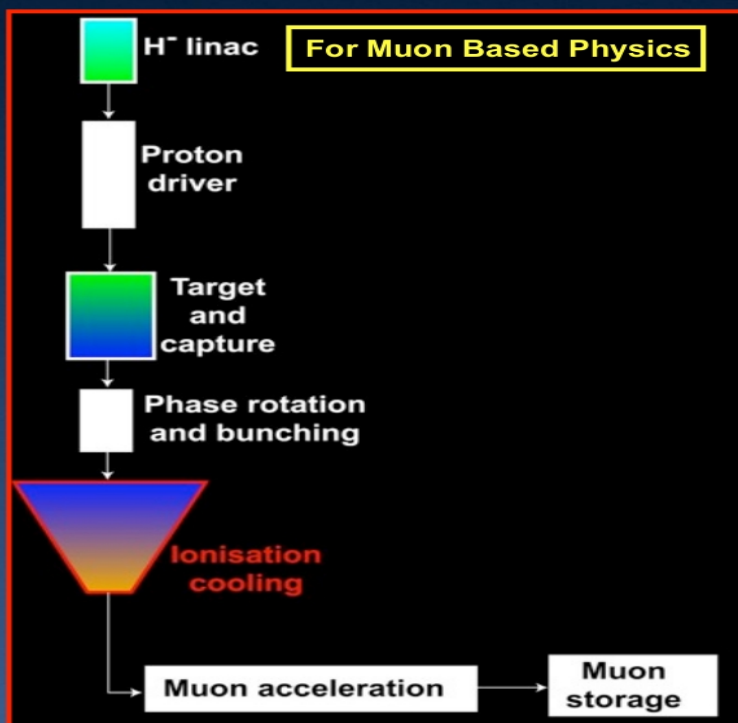

- **High power proton driver**
- **Pion production and capture**
 - target system, super-conducting magnet, radiation damage, hadron codes ...
- **Muon beam transport**
 - bend solenoid with a dipole field
- **Phase rotation**
- **FFAGs**
- **Kickers and RF**
- **Techniques in machine design and beam dynamics studies**
- ...

Studied in **MuSIC**, **COMET** and **PRISM**

Strong relationship b/w NF/MC and muon group is important.

Wide experience has been accumulated :

PRISM Task Force

J. Pasternak (contact person)

- The PRISM FFAG work
- The aim of FFAG based accelerator experiment
- The following within the
 - - physics
 - - proton
 - - pion capture
 - - muon
 - - injection
 - - FFAG magnet
 - - FFAG magnet
- Studies will

Syne

Akira SATO

MuSIC is a new intense DC muon beam source, which is now under construction at RCNP, Osaka. **We have already build a superconducting pion capture system. The target muon intensity is $10^8/s$**

The world 1st Pion Capture System with Superconducting Magnet for MuSIC at RCNP, Osaka, JAPAN



The 1st beam test has been performed at 29-30 July, 2010.
The 2nd beam test will be in January 2011.

Etc.

This is a potential ground for objectives of reinforced

Relationship among the programs

towards the ultimate μ -e conversion study

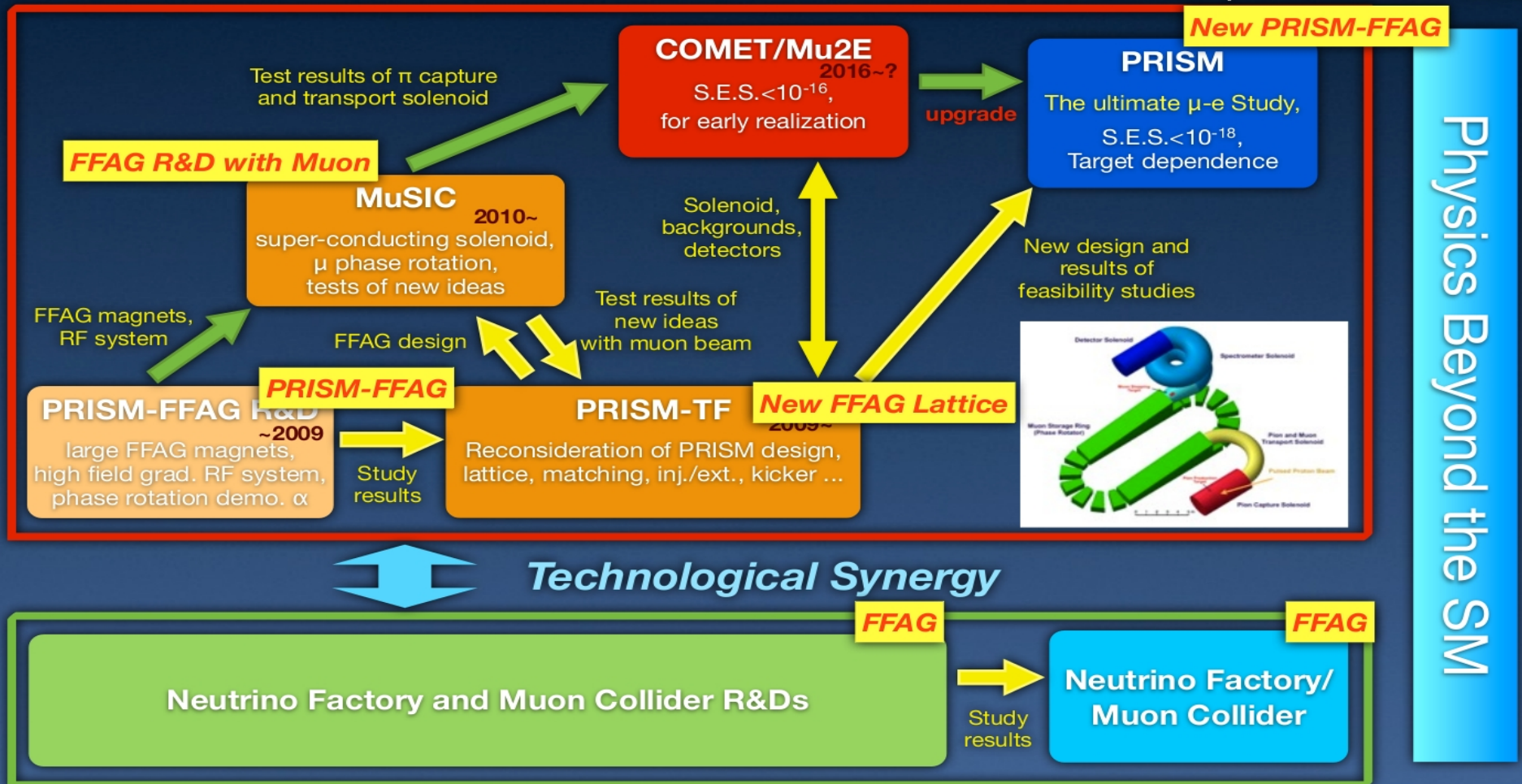

Thu, 11:30-12:00, 5th talk

FFAG for ADS-R & Ion Therapy

Carol Johnstone, FNAL

- NL-NS-FFAG designs are advancing rapidly internationally,
- Isochronous non-scaling FFAGs have been developed
- Embedded rings are an exciting new direction for multi-ion therapy
- Advanced design and simulation tools have been developed in COSY



Example : advanced design and simulation of an Isochronous 250-1000 MeV Nonscaling FFAG

2m

General Parameters :

<i>Parameter</i>	<i>250 MeV</i>	<i>585 MeV</i>	<i>1000 MeV</i>
Avg. Radius (m)	3.419	4.307	5.030
Cell $\frac{x}{y}$ / $\frac{x}{y}$ (2 π rad) Ring	0.380/0.237 1.520/0.948	0.400/0.149 1.600/0.596	0.383/0.242 1.532/0.968
Field F/D (T)	1.62/-0.14	2.06/-0.31	2.35/-0.42
Magnet Size F/D Inj	1.17/0.38	1.59/0.79	1.94/1.14

- Comments and further work
 - Tracking results indicate ~50-100pi mm-mr; relatively insensitive to errors
 - Low losses

Example : field map and tracking in a 250-1000 MeV proton driver

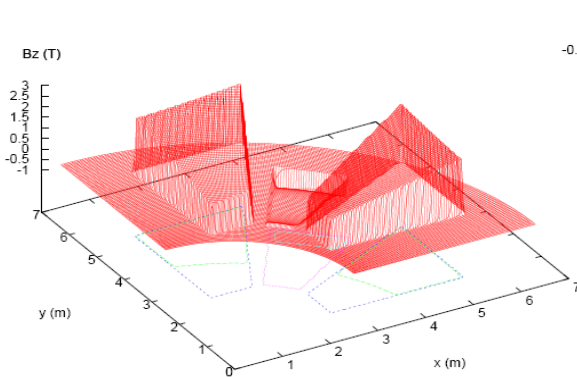

- **Immediate large DA aperture:**
 - 50-100 mm-mr without correction
 - 0.1-1% error tolerance –typical magnet tolerances
- **Final isochronous optimization will be performed using advanced optimizers in COSY**

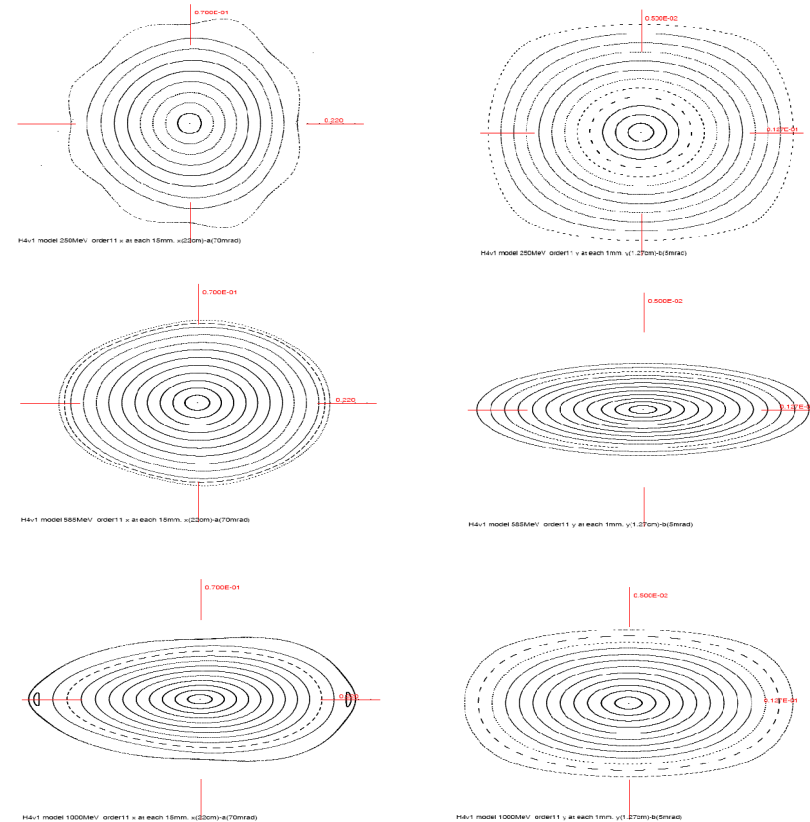

Dynamic aperture at 250, 585, and 1000 MeV – step size is 15 mm in the horizontal (left) and 1 mm in the vertical (right).

Summary of advantages based on advances in FFAG technology

- **CW operation** (into relativistic energies) with new isochronous lattices
 - Simplicity and lower cost of fixed-frequency rf
- **Strong focusing, yielding**
 - Large, stable dynamical acceptance
 - Lower losses, particularly with smaller beam envelopes in vertical
 - Support of multiple long straights
 - Lowered extraction losses
 - Mitigation of space charge effects (strong tune in vertical), higher bunch intensities
 - Resonant and kicker-based extraction (horizontal and vertical)
 - Variable energy without use or reduced use of a degrader
 - Improved beam transmission at low energies
 - Respiration gating can be kicker based
 - Reduced shielding requirements – reduced civil costs
- **Nested Rings**
 - Compact footprint even for a multi-ion facility



Thu, 12:00-12:30, 6th talk

RACCAM

François Méot, BNL

RACCAM : A variable energy FFAG proton-therapy assembly

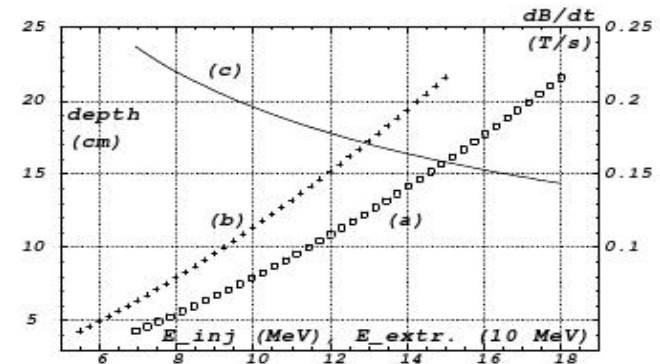
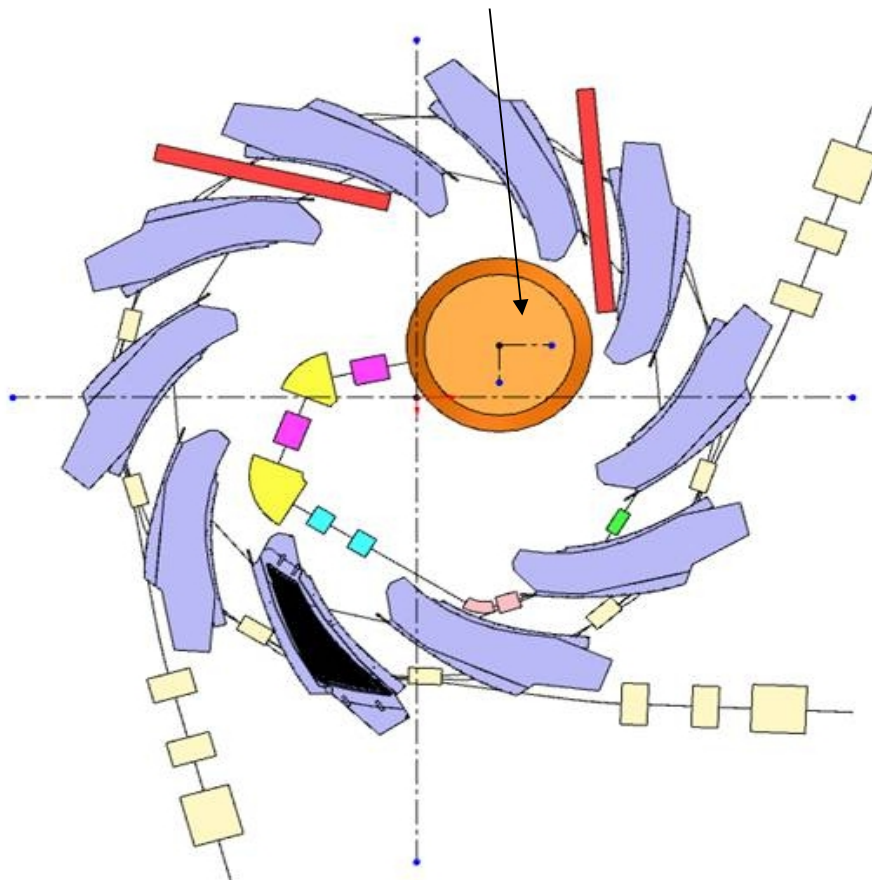

(a) : Bragg pic depth as a function of FFAG extraction energy

(b) : correlated cyclotron energy with 250kV steps

(c) : dB/dt

Extraction energy, variable	70 – 180 MeV
Injection energy	5.5 – 17 MeV
Momentum ratio	3.62
Number of cells	10
Packing factor	0.34
Field index, k	5
Spiral angle	53.7 deg.
Q _h / Q _v	2.76 / 1.55-1.60
Radius on extraction/injection orbit : dR	3.46 m / 2.78 m / 0.67 m
Drift length, extraction/injection orbit	1.42 m / 1.15 m
Frev, 15->180 MeV	3.03 -> 7.54 MHz
Frev, 5.5->70 MeV	1.86 -> 5.07 MHz

Magnet prototyping

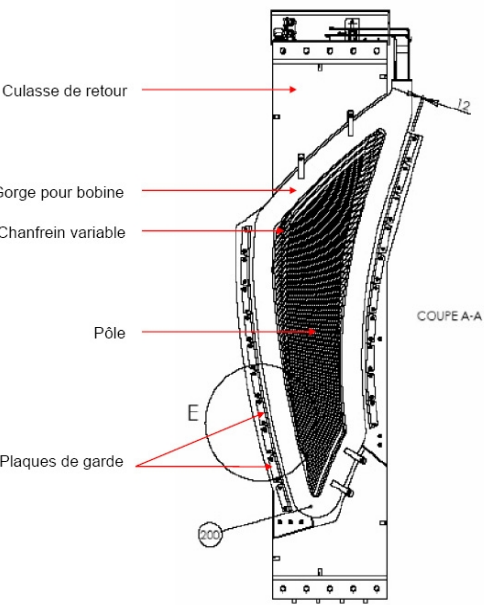

Magnetic measurements, summary of data analysis

- field integrals (th. 36deg, normalized),
- sector angle A (th. 12.24 deg)
- local k from B (taken at A/2)
- average k from BL (th. 5.00),
- spiral angle at entrance/exit

Type	Gap shaping
Packing factor (pf)	0.34
Field index (k)	5
Spiral Angle (ζ) (deg)	53.7
Min./Max. radius of good field region (m)	2.9/3.3
Max. field at min./max. radius (T)	0.58/1.7
Bend angle (β) (deg)	36
Sector angle (A) (deg)	12.24

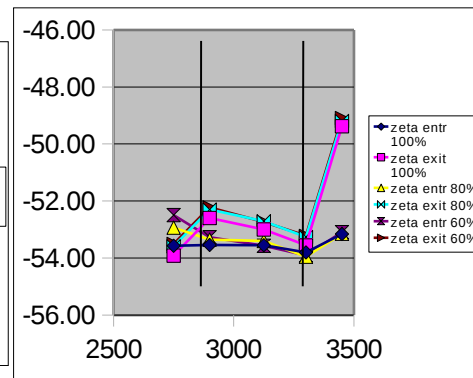
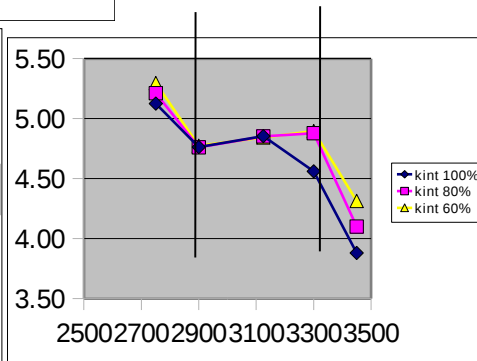
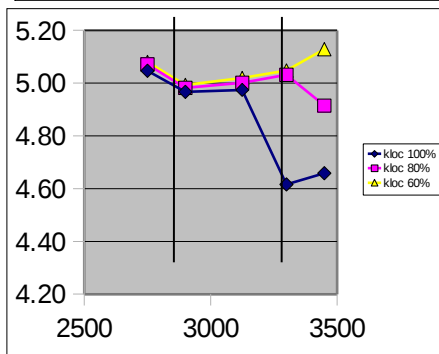
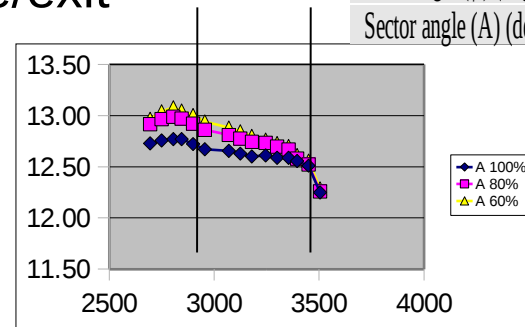
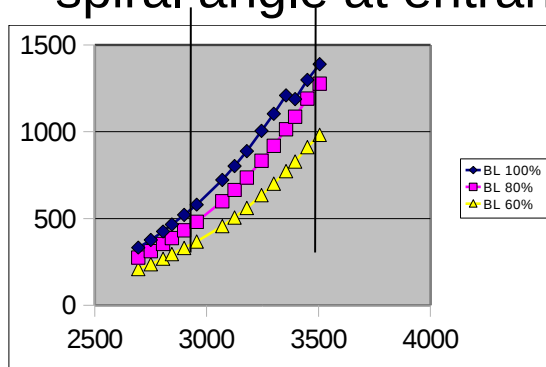

“RACCAM hospital” has been devised

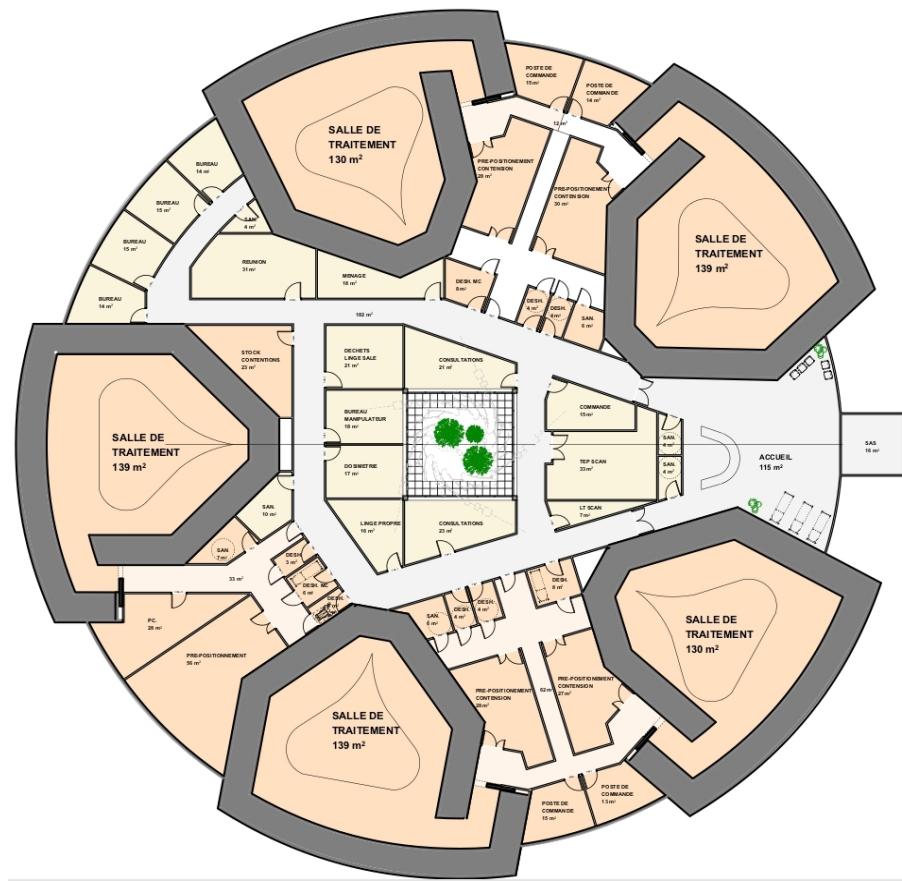

Session cost
decreased by ~2

	état de l'art [15]		scénarios RACCAM								
	IMRT	proton	base	1	2	3	4	5	6	7	8
temps / jour (h)	14	14	14								16
jours / semaines	5	5	5								
semaines / an	50	50	50								
nb salles	2	3	5							10	
TDS (%)	98%	96%	96%	80%							
temps / fraction (min)	10	18	18		22						
fractions / patients	18	20	20								
patients / FTE	56,609	17,125	17,125			56,609	30	40	50	40	40
coût batiment TTC (m€)	10,979	28,704	23,92							40	
capacité annuelle	2287	1680	2800	2333	2291	2800	2800	2800	2800	5600	3200
personnel (FTE)	40	98	164	136	134	49	83	70	56	140	80
cout [15] / fraction	233 €	743 €									
cout LPSC / fraction	257 €	762 €	628 €	681 €	687 €	399 €	487 €	440 €	412 €	407 €	407 €
ratio / RX	1,00	2,96	2,44	2,65	2,67	1,55	1,89	1,71	1,60	1,58	1,58
gain / [15]			-18%	-11%	-10%	-48%	-36%	-42%	-46%	-47%	-47%

Cost reduction /1.9

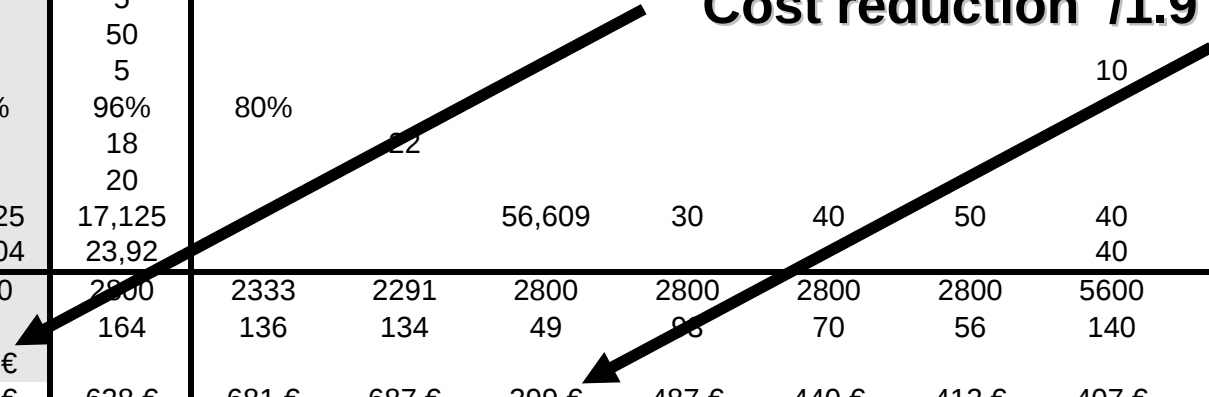

Thu, 13:30-14:00, 7th talk

EMMA: Toward Acceleration

Shinji Machida, RAL

EMMA's main goals

- Serpentine acceleration (or acceleration outside the bucket.)
- Fast resonance crossing without beam deterioration.
- Large acceptance in both longitudinal and transverse.

Acceleration (1) *signals*

- Relative phase vs turn.
 - Relative phase measurement.
- Cell tune vs. turn.
 - BPM measurement (H and V)
- Horizontal position.
 - BPM measurement (H)

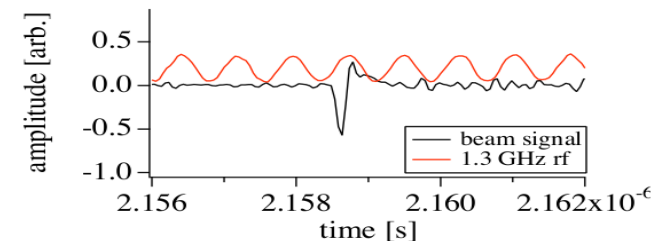

Things have been done

- Injection between 14.5 and 20.5 MeV/c equivalent* momentum.
- There is a few stopbands in between.
- Tune is lower than expected, but within error bar.
- Time of flight per turn is about 50 ps lower.
- A few 10 of thousands circulations.
- ALICE beam is always 12.5 MeV/c. Change magnet strength keeping QD/QF ratio constant.

Two major problems identified

- rf vector sum of 19 cavities is lower than expected. Cavity phase was not correctly adjusted.
- Closed orbit distortion was rather large ($\sim \pm 5$ mm) in both horizontal and vertical.
- Only 12 BPM signals (either H or V) are available at one time.

Cavity phase (4)

rf voltage for serpentine channel

- Two rf bucket merges and create serpentine channel with more than 0.9 MV per turn.
- There should be enough rf voltage after adjusting individual cavity phase.

- With 1.32 MV per turn, a beam in serpentine channel behaves differently.

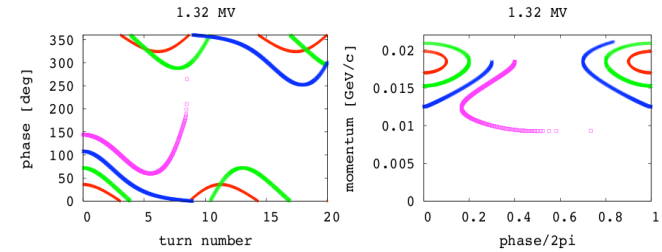

6

Closed orbit distribution (2)

after correction

- After correction.

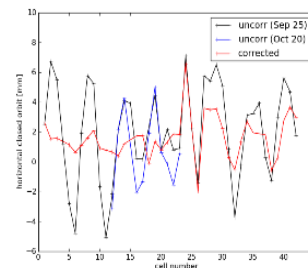
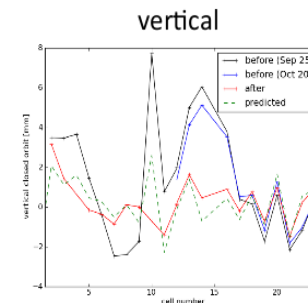
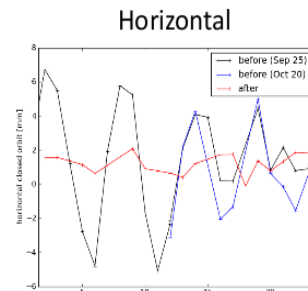

- COD is reduced to $\sim \pm 1$ mm
 - Shift of 84 magnets in H
 - 16 V corrector in V

Thu, 14:00-14:30, 8th talk

Accelerator R&D for the Neutrino Factory and Muon FFAGs

Jaroslav Pasternak, IC

Neutrino Factory, facility for precision neutrino physics

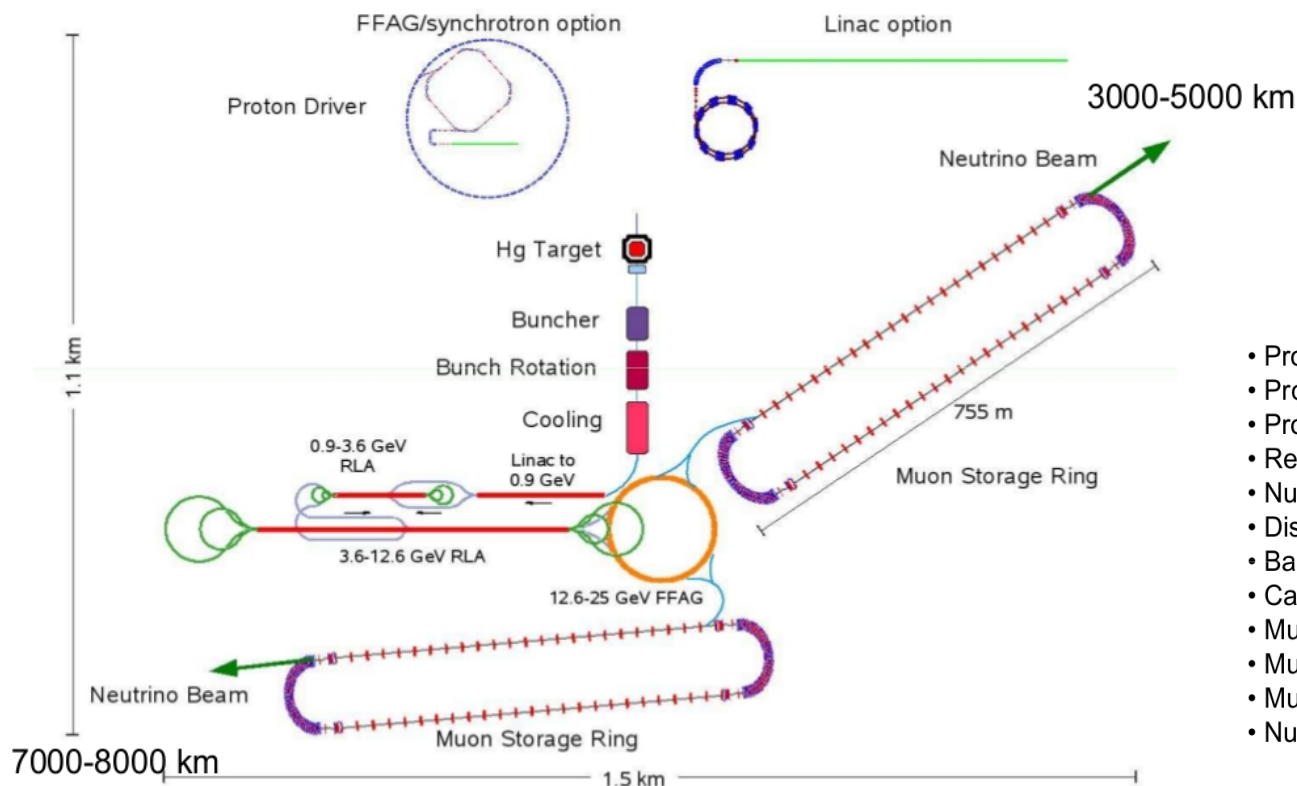

Neutrino Factory parameters

- Proton beam power **4 MW**.
- Proton bunch length at the target $\pm 2-3$ ns rms.
- Proton beam energy 5-15 GeV.
- Repetition rate 50 Hz.
- Number of proton bunches per macropulse 3.
- Distance between proton bunches ~ 160 us.
- Baseline target – Mercury jet.
- Capture system – **20 T** solenoid.
- Muon front end – bunching/phase rotation/ionization cooling.
- Muon train length 80 m (52 201 MHz bunches).
- Muon cooling/acceleration RF frequency 201 MHz.
- Number of muons stored in the decay ring $\sim 10^{21}$ per year.

Progress on FFAG

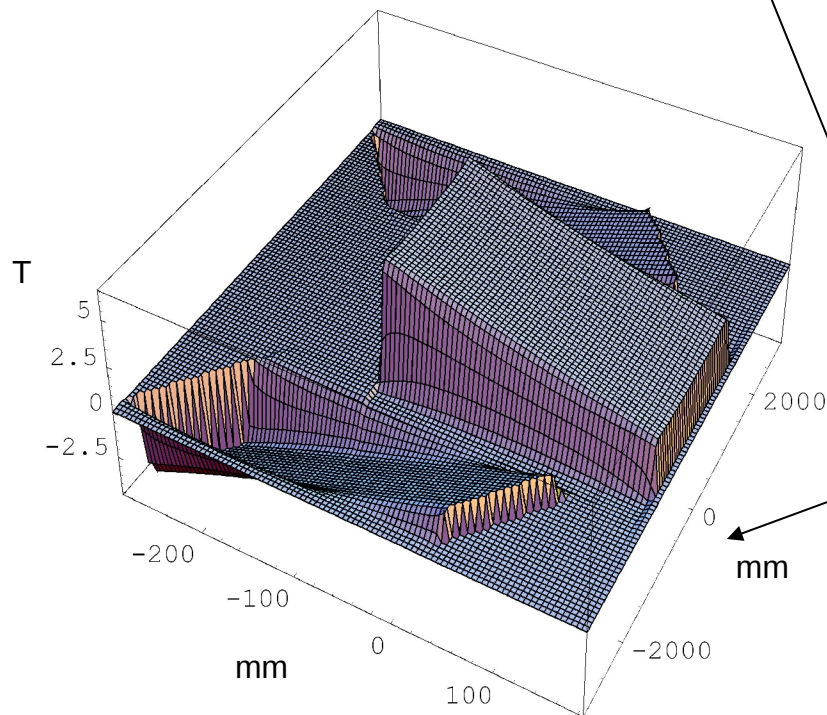
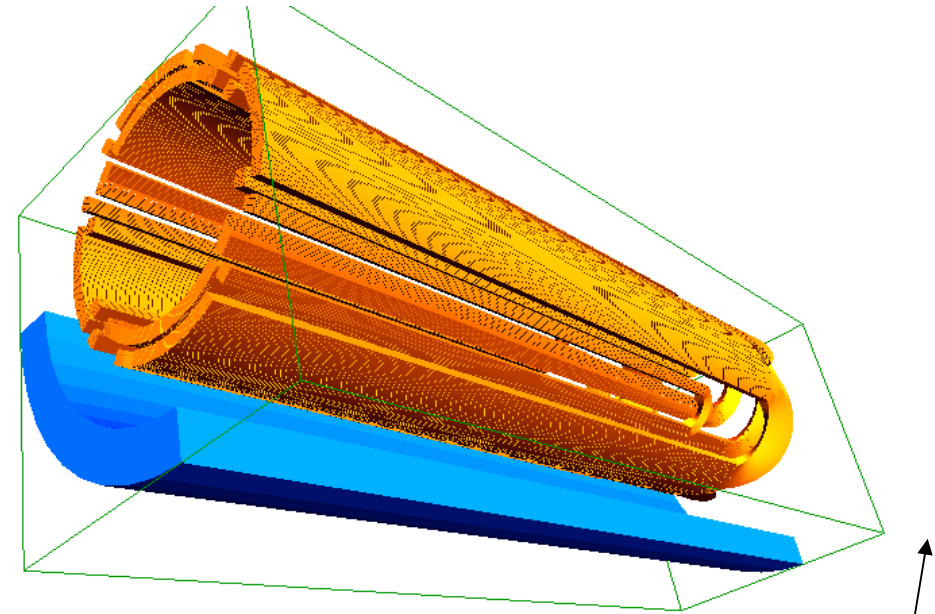
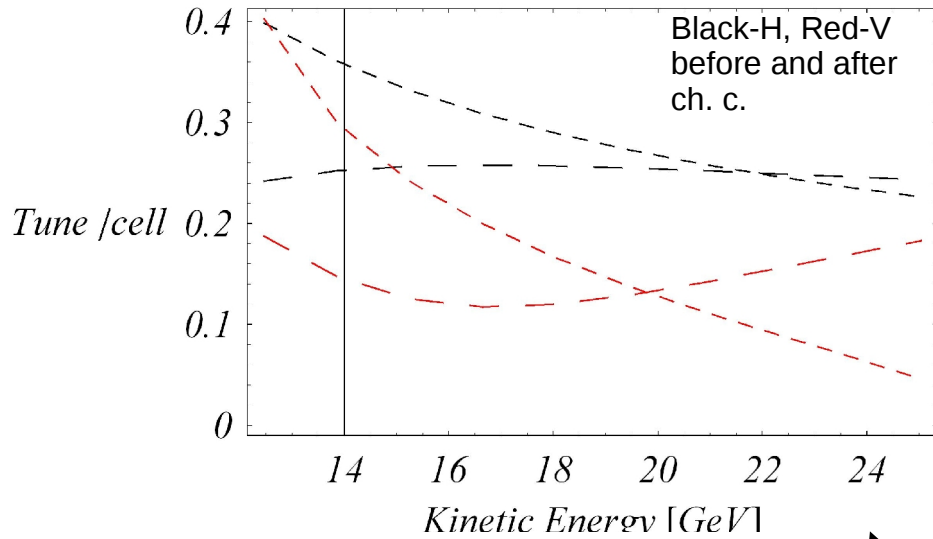

- Baseline lattice was chosen.
- Chromaticity correction is being studied in order to reduce the TOF problem.
- SC main magnet design using ROXIE code is advancing.
- Tracking studies using realistic field maps using Zgoubi code (work in progress).
- Injection/extraction schemes have been designed.

Injection/Extraction hardware design

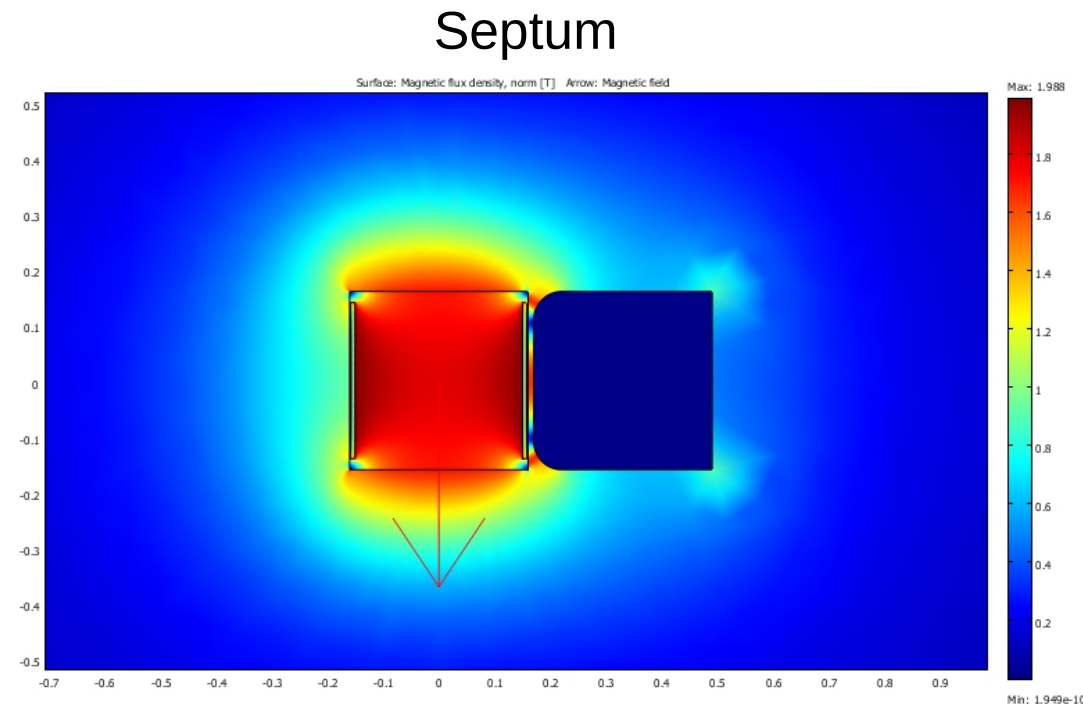
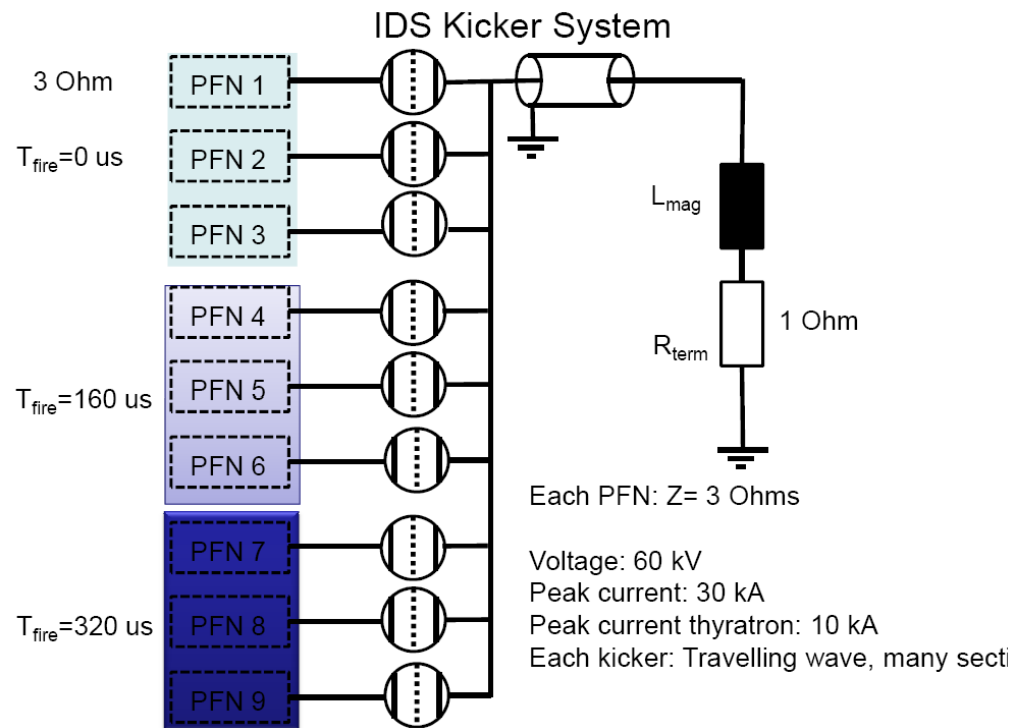

- The kicker system was designed and looks feasible, but the hardware tests would be needed to demonstrate the life-time of critical components (switches).
- The detailed design of the kicker is needed (RDR).
- 2D simulations of the field leakage from the septum limits the magnetic field to $\sim 2 \text{ T}$.
- The septum strength determines the FFAG drift length (5 m) .
- The energy deposition in the superconducting septum and its quench limit needs to be studied.

Injection/Extraction geometries

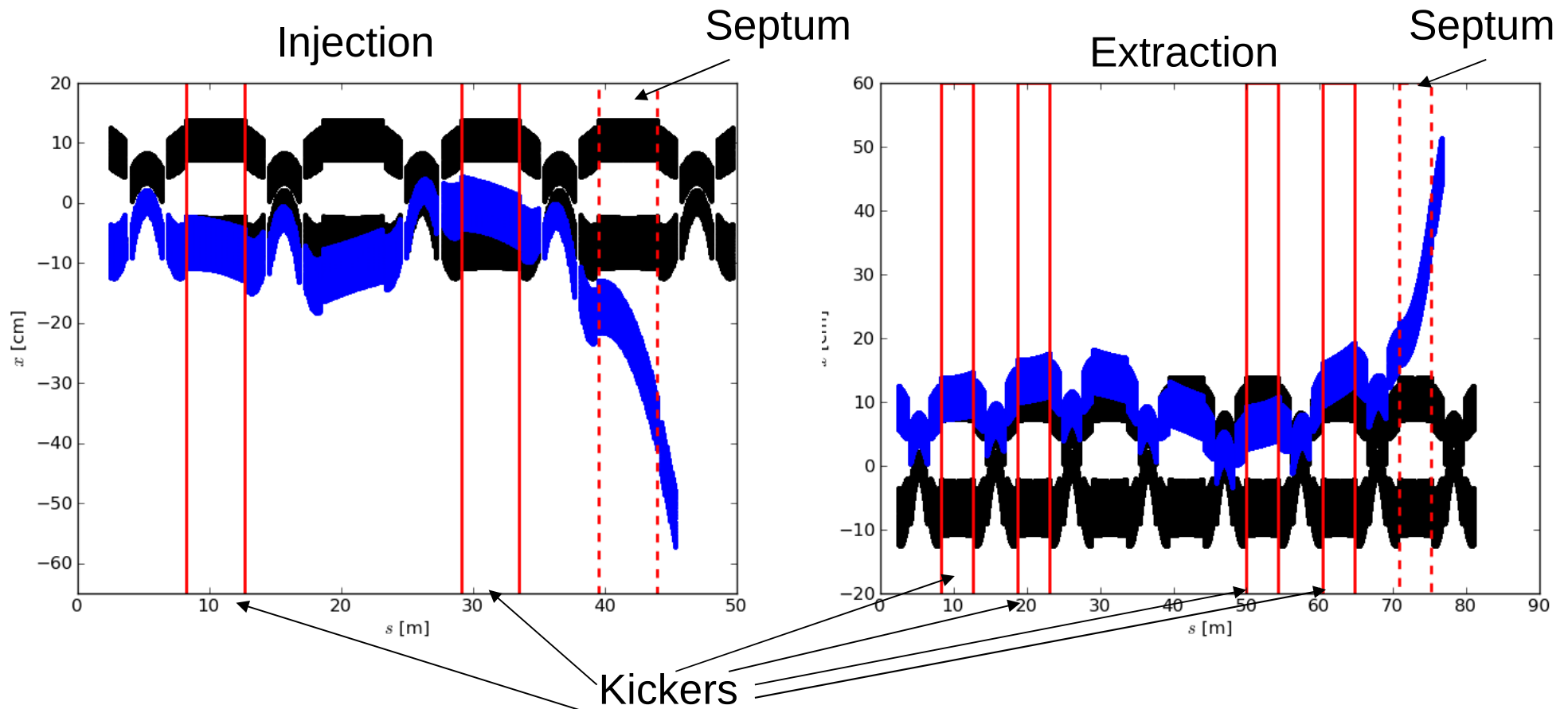

- Baseline injection and extraction are in the horizontal plane.
- In order to reduce the kicker strength it is proposed to distribute them in a few cells.
- Kicker field is below 0.1 T and septum ~ 2 T.
- Apply mirror symmetric solution to reuse kickers for both signs of muons.
- Special magnets with larger apertures are needed in the injection/extraction regions.

Summary for muon FFAGs

The Neutrino Factory IDS baseline was updated in order to allow for realistic injection/extraction.

The drift length (5 m) is dictated by the achievable septum field (~2T).

Horizontal injection/extraction schemes were selected, as they require smaller increase of aperture in special magnets placed in the injection/extraction regions.

The kicker system was designed and looks feasible, but the hardware tests would be needed to demonstrate the life-time of critical components (switches, capacitors etc.).

2D simulations of the field leakage from the septum limits the magnetic field to 2 T.

The alternative low energy acceleration solution to replace RLA II was designed based on scaling FFAG.

FFAGs are essential for a future muon HEP program (Nufact, PRISM/PRIME, Muon Collider).

Thu, 14:30-15:00, 9th talk

Zero-Chromatic FFAGs for Future Neutrino Factories and Muon Colliders

Thomas Planche, KURRI

- The possibility to use zero-chromatic FFAGs as an injector of the non-scaling FFAG in the neutrino factory is now considered.
- Two novel schemes are proposed
 - one is based on HNJ acceleration
 - a second one is based on “Stationary Bucket acceleration”.

“Harmonic Number Jump acceleration”.

A novel type of zero-chromatic FFAG lattice, includes dispersion reduced insertion, overcomes the limitations of this particular acceleration scheme.

Example of a 3.6 to 12.6 GeV ring

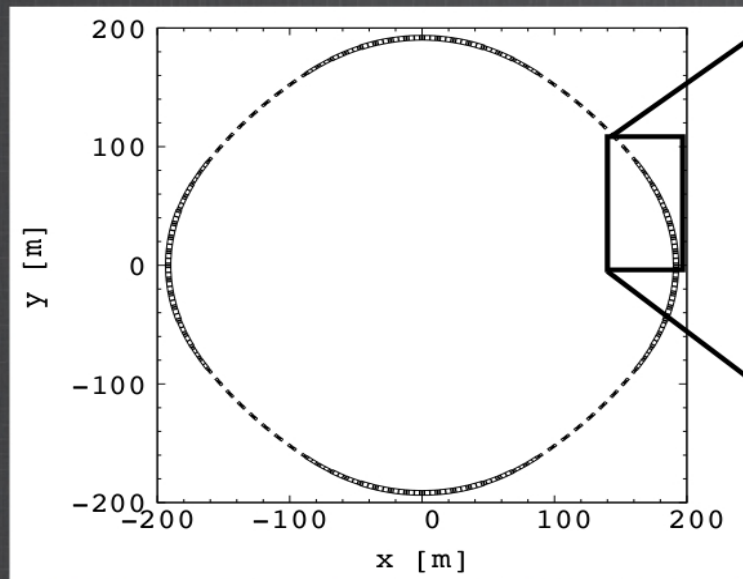
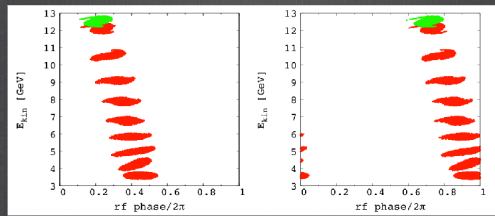

Schematic view of the ring made of quadruplet two-beam cells.

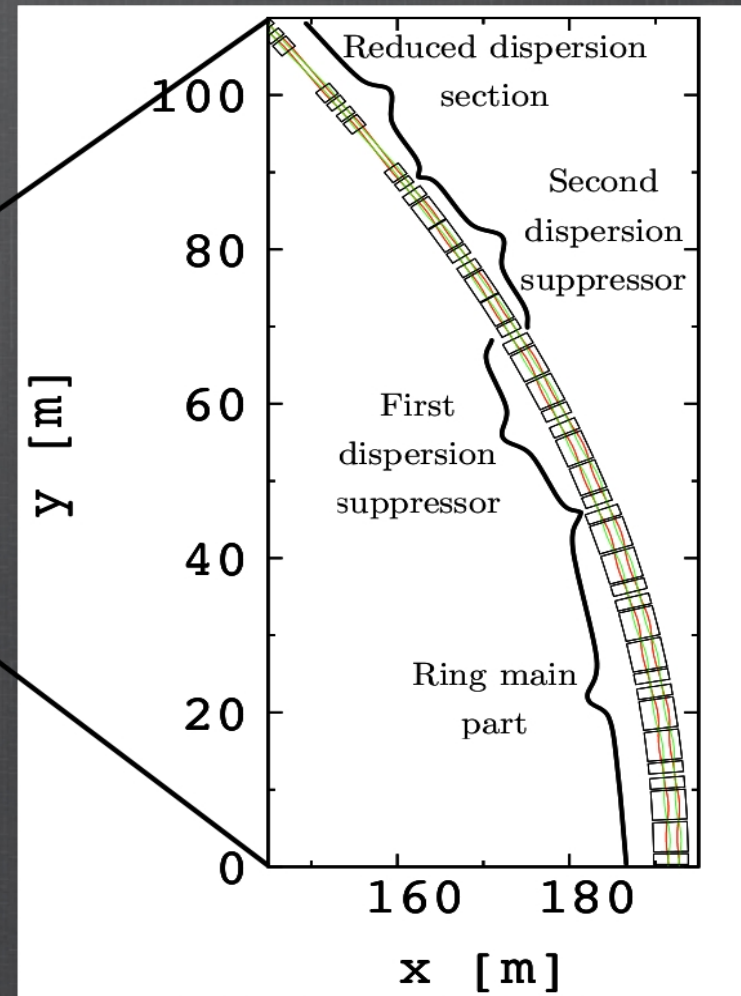

“Stationary Bucket acceleration”.

This scheme has a strong potential of **significant cost reduction** of the present baseline design of the Neutrino Factory.

Example of a 3.6 to 12.6 GeV muon ring

Table 1 - Scaling FFAG muon rings parameters

Lattice type	FDF triplet
Injection (kin) energy	3.6 GeV
Extraction energy	12.6 GeV
rf frequency	200 MHz
Mean radius	~ 161 m
Synchronous kinetic energy	8.04 GeV
Harmonic number h	675
Number of cells	225
Field index k	1390
Peak rf voltage (per turn)	1.8 GV
Number of turns	6
B_{max} (@ 12.6 GeV)	3.9 T
Drift length	~ 1.5 m
Horiz. phase adv./cell	85.86 deg.
Vert. phase adv./cell	33.81 deg.
Excursion	14.3 cm

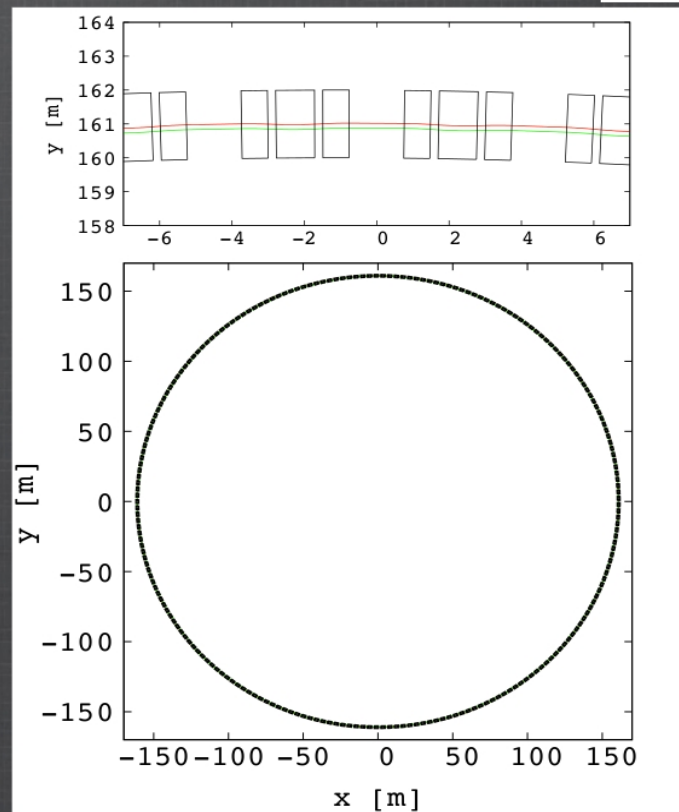
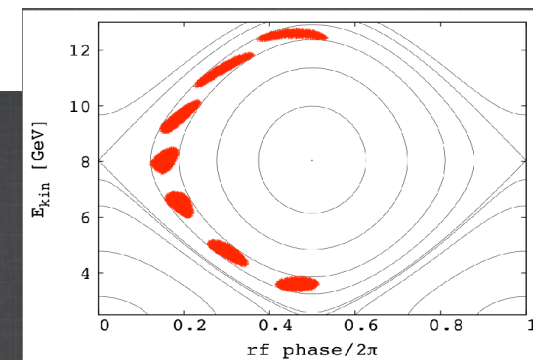

Thu, 15:00-15:30, 10th talk

Advanced Scaling FFAG Systems

Jean-Baptiste Lagrange, KURRI

Experiment

Dispersion suppressor and magnets

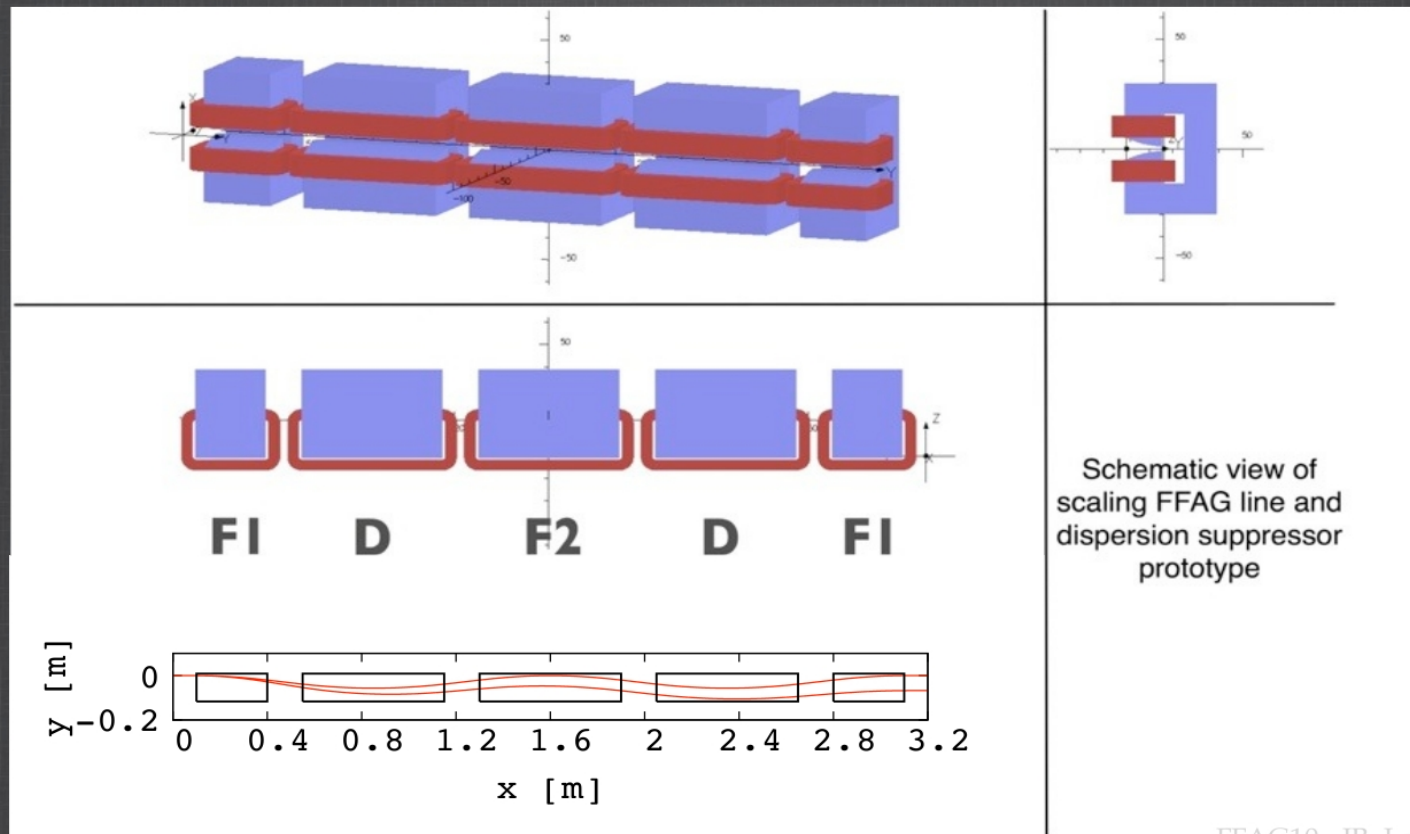

Applications

General Principle

Ring part
 $B \propto r^k$

Dispersion
suppressor

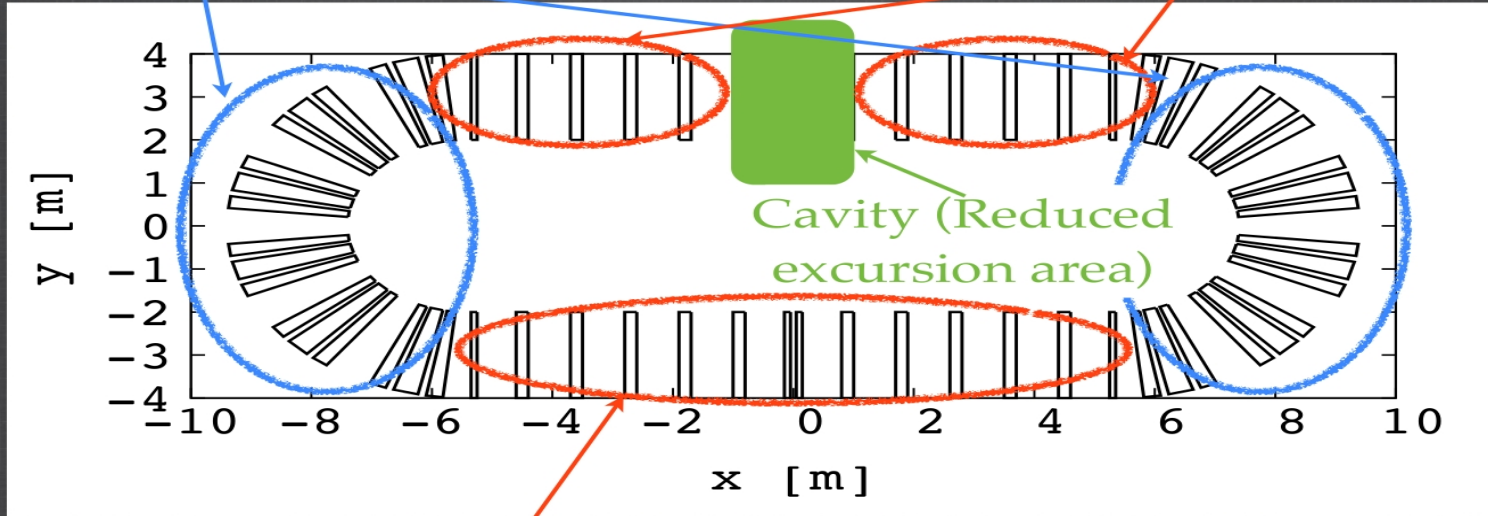

Straight section: Injection
 $B \propto e^{mx}$ Extraction

FFAG10 - JB. Lagrange

Race-track scaling FFAG PRISM

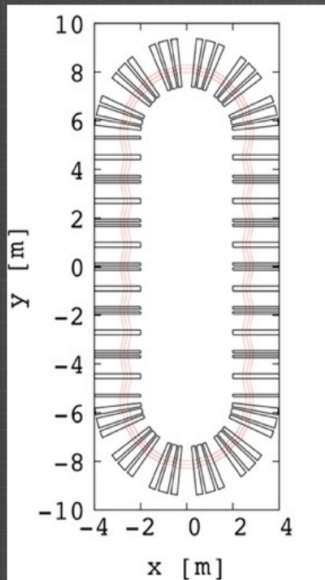

Bending cell FDF triplet
k-value 2.55
 Average radius 2.7 m
 Phase advances:
 Horizontal μ_x 60 deg.
 Vertical μ_z 90 deg.
 Dispersion 0.8 m

Straight cell
m-value 1.3 m^{-1}
 Length 1.8 m
 Phase advances:
 Horizontal μ_x 27 deg.
 Vertical μ_z 94 deg.
 Dispersion 0.8 m

Applications

Gantry

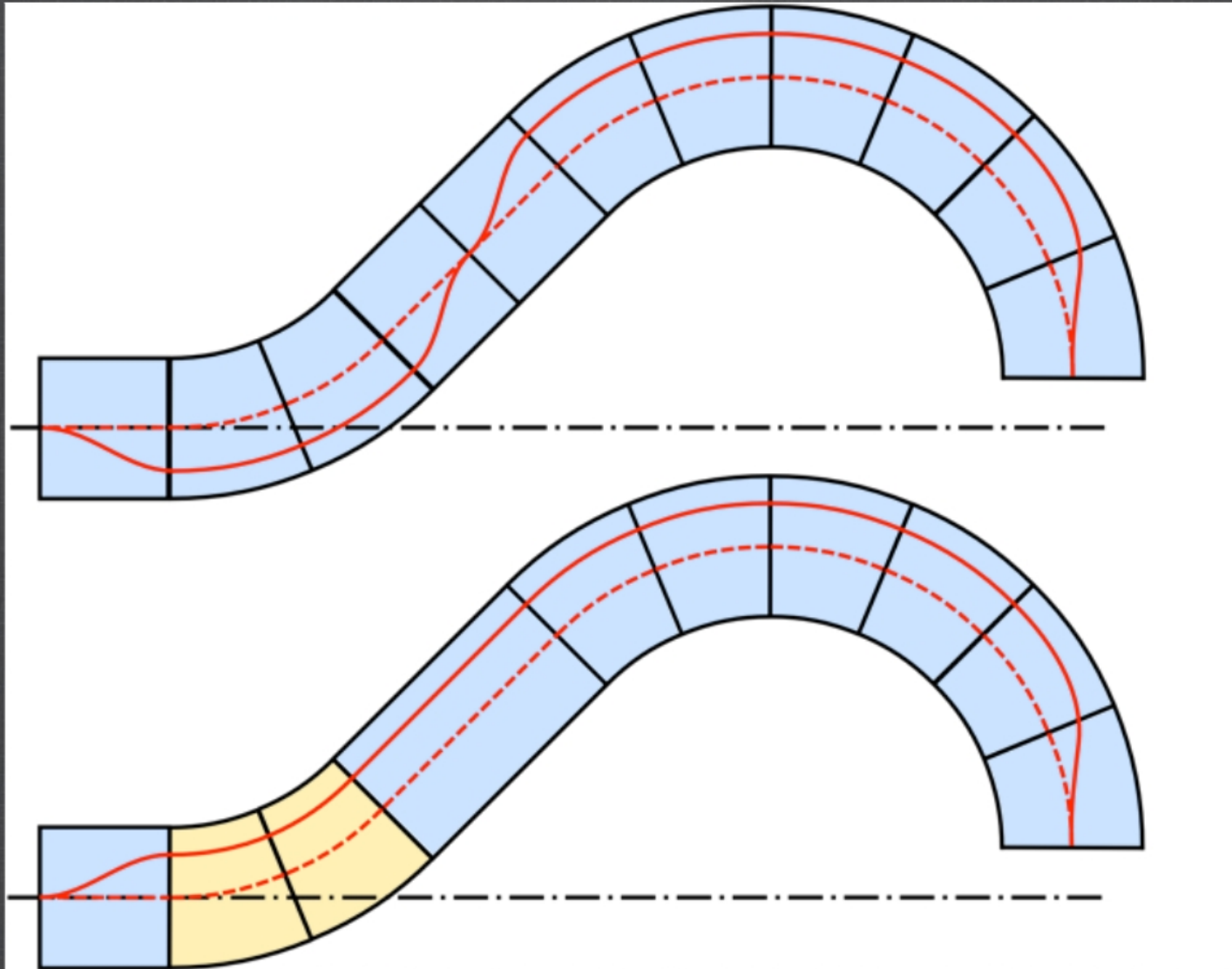

Thu, 15:30-16:00, 11th talk

**Using ELEGANT for FFAG and RLA
tracking**

Yves Roblin, JLAB

Yves Roblin, Jefferson Lab

Neutrino Factory IDS

- **Currently performing detailed tracking of the first linac**
 - **Full field maps** for cavities and solenoids.
 - Still optimizing longitudinal and transverse optics
 - Currently 70 % transmission (without muon decay)
- **Proposing non-scaling FFAG arcs** instead of standard dogbone return arcs.
- **Full start-to-end simulation being developed**, including chicanes and matching sections between linac and FFAG arcs.

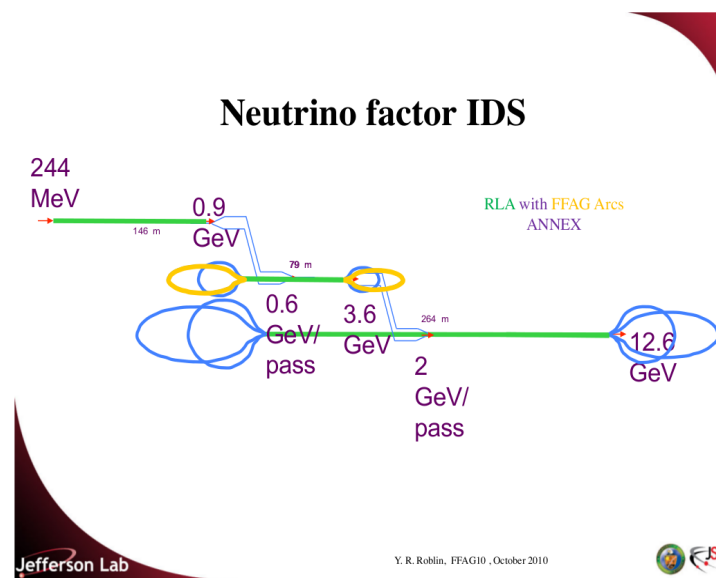

- **Using ELEGANT (drift/kick code)** with massively parallel capabilities.
- **Better models/improvements for ELEGANT under way** (cavity models, 3D field map tracking. Etc..)
- **Fringe field models, 3D field maps imports** and normalization, symplectic tracking in fields, TPSA/DA ?)

Thu, 16:00-16:30, 12th talk

Longitudinal Beam Dynamics Studies in EMMA

Jimmy Garland, Manchester Univ.



Building a code Fundamentals of the Code



- This parabolic shape of the time of flight curve as a function of energy can be approximated by a 2nd order Taylor expansion:

$$ToF = P_1 + P_2 E + P_3 E^2$$

- The constants P_1 , P_2 and P_3 then represent a particular lattice for EMMA based on a particular simulation given by a code such as MADX.

- Built a simple longitudinal code to simulate the longitudinal properties of the beam.
- No Hamiltonian formulation, instead based on the ToF per cell as a function of Energy curve given by Shinji Machida's code.

- Basic input parameters are:
 - The EMMA lattice containing 42 cells and 19 cavities
 - The RF frequency, phase and voltage of the cavities
 - The initial energy 'E' and the longitudinal coordinate 'l' with respect to a reference orbit moving with a time of flight corresponding to a specified RF frequency

Aims at understanding EMMA experiments observations, as

Buckets and the Gutter

- Modeled the acceleration as a function of voltage in the cavities...

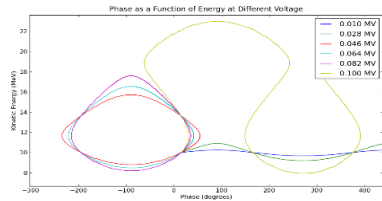
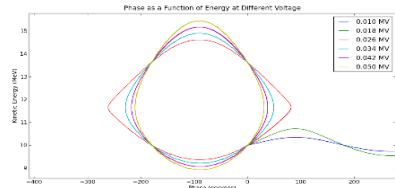

11

Phase Errors

- Other 2/3 of the time we get...

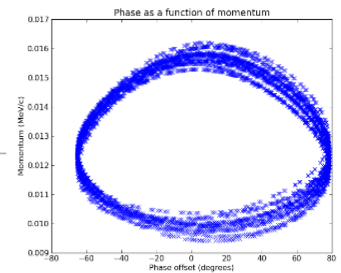
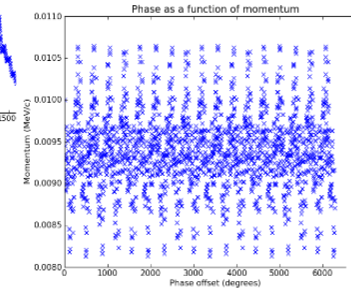
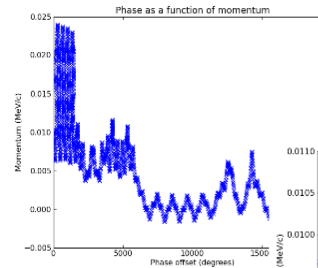

explain this yet.
ments?

Synchrotron Tune

- Could this mean that we have some uncertainty in our knowledge of the RF voltage in the cavities?

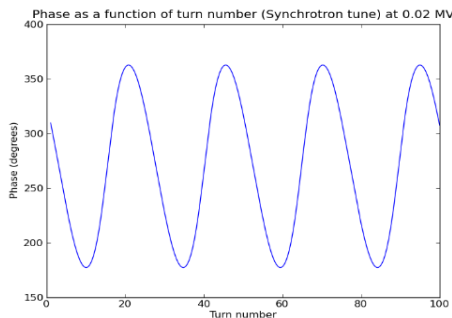

A value of approximately 0.38MV per turn gives a tune of 0.04 in simulation. .

Perhaps my code has problems...

17

Conclusions

Writing this code has been valuable for learning simple longitudinal dynamics.

I have modeled (hopefully correctly!) some important properties of EMMA such as the serpentine acceleration.

Next steps are to start to bench mark my code with other codes to work out any errors. Also possibly write a full canonical model (Hamiltonian formulation).

Need to work out why model and measurement disagree on synchrotron tune.

When EMMA runs again after Christmas, hopefully we will see serpentine acceleration!

Thu, 16:45-18:00 session

Radiopharmaceutical Production Using Microreactor

S.Y.Jung

Everything you need to know about
the chemical microreactor,

.1 What is MicroReactor?

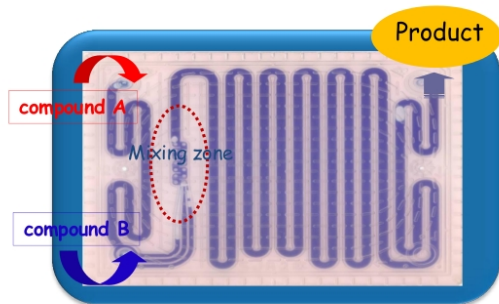

Keywords

- ✓ microcircuit
- ✓ Diffusion and eddy
- ✓ Mixture of compounds

PROCESS of reaction

- Supplying compound A,B in the microcircuit with pumps.
- Along the microcircuit, compounds are stirred through the mixing zone.
- Transferring along the circuit, reaction completed and producing the final compound.

and about its advantages in
everyday's life



- ✓ Construction for safety
- ✓ safeguard in whole building

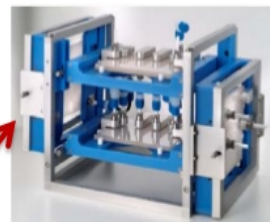

Construction for
local space

Fri, 9:00 , 1st talk

Overview of RIB Facility KORIA

Jong-Seo Chai, Sungkyunkwan Univ.

Multipurpose Facility

- Nuclear Physics and Nuclear Astrophysics
- Material Science using stable HI & RIB
- Bio and Medical Sciences with HI & RIB
- Atomic Physics & Fundamental Symmetry
- Nuclear Data Production for Energy
- Nuclear Fusion (Plasma)

The World's
20 Greatest
Unsolved Problems

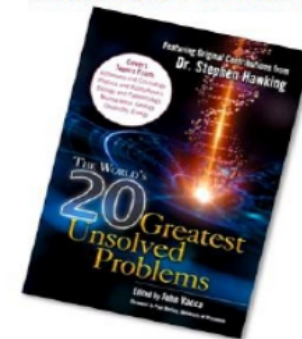

KoRIA layout

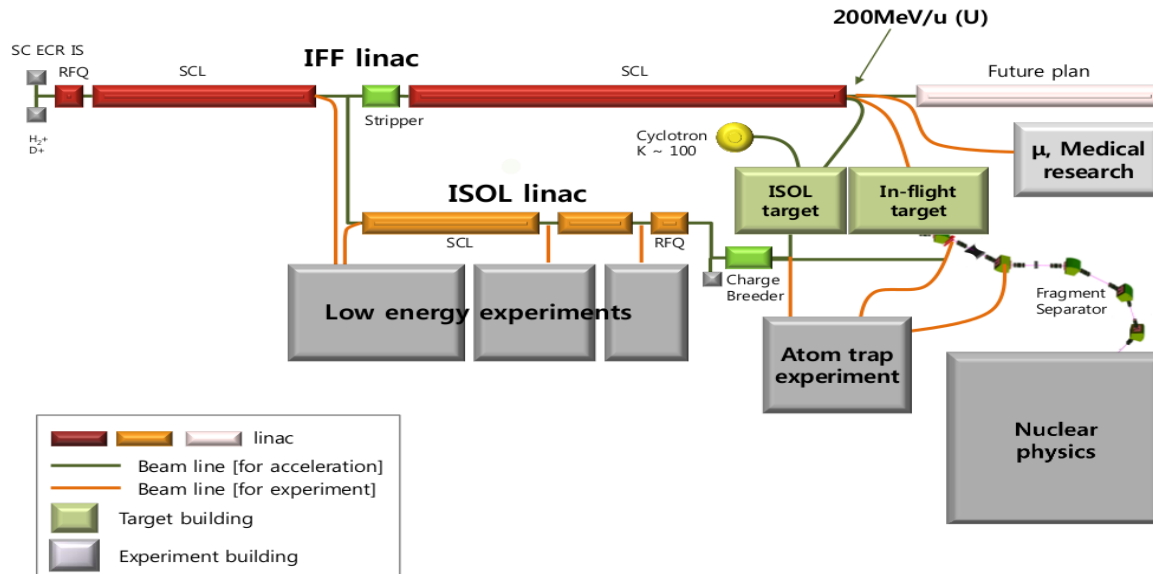

KoRIA Project Schedule

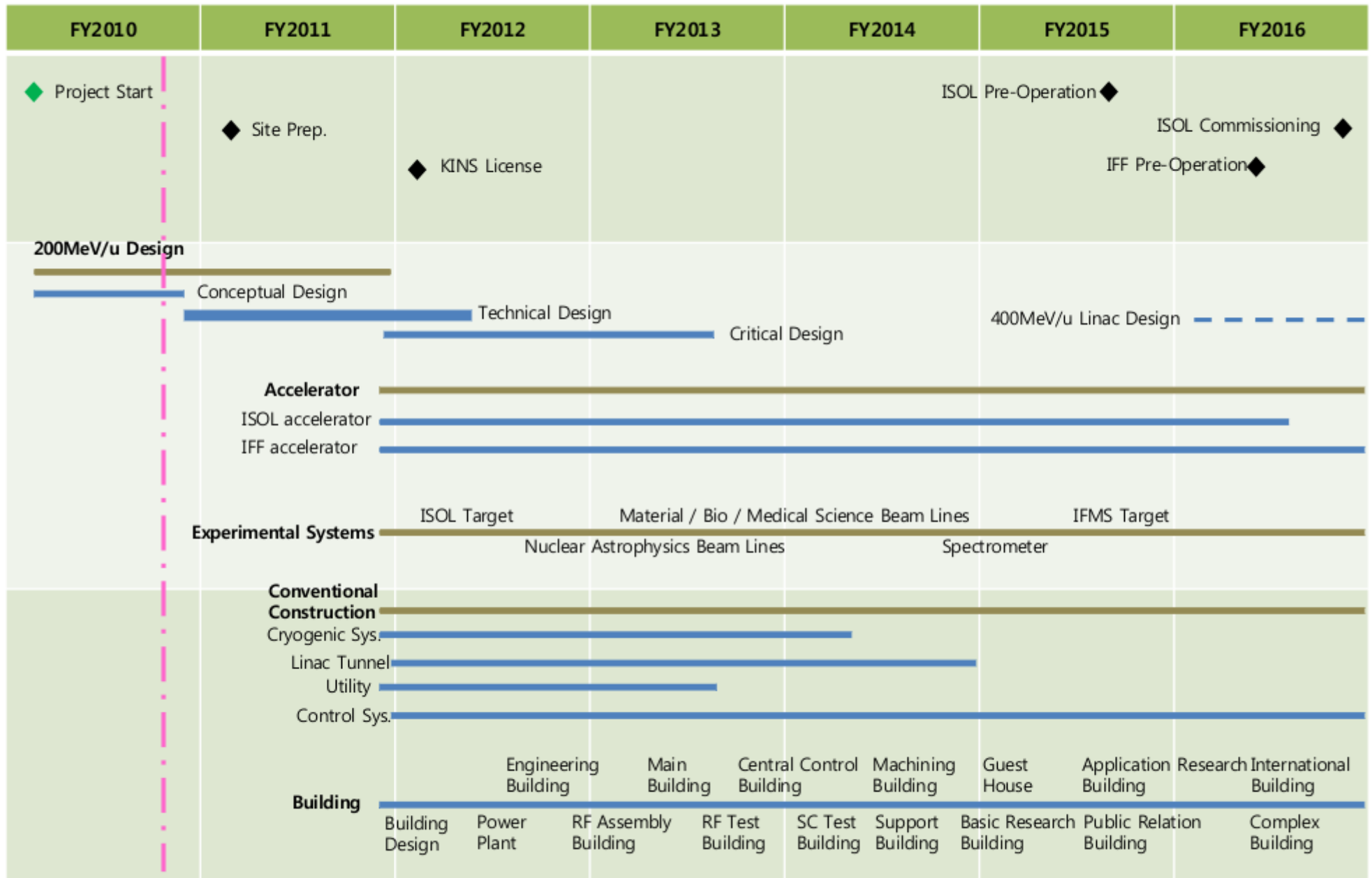

Thu, 16:45-18:00 session

Design Study of Injector Cyclotron for K-100 SSCB

J. Oh

Lab. of Accelerator & Medical Engineering AnME

The cyclotron 8MeV/1mA H- driver for KORIA Layout of ISOL Driver

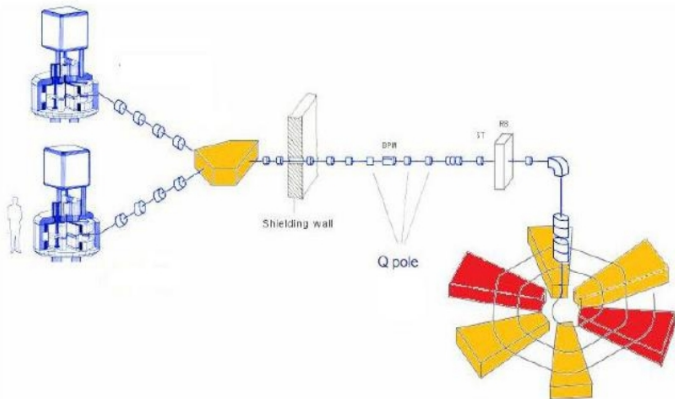

home.skku.edu

8 MeV Injector Cyclotron

8 MeV SF Cyclotron
4 Sector Magnet
Deep Valley
4 th Harmonics
Expected Beam Intensity
500uA ~ 1 mA

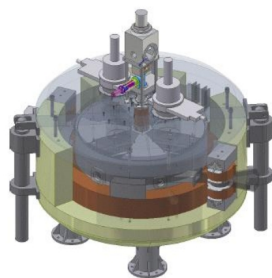

Lab. of Accelerator & Medical Engineering AnME

KoRIA layout

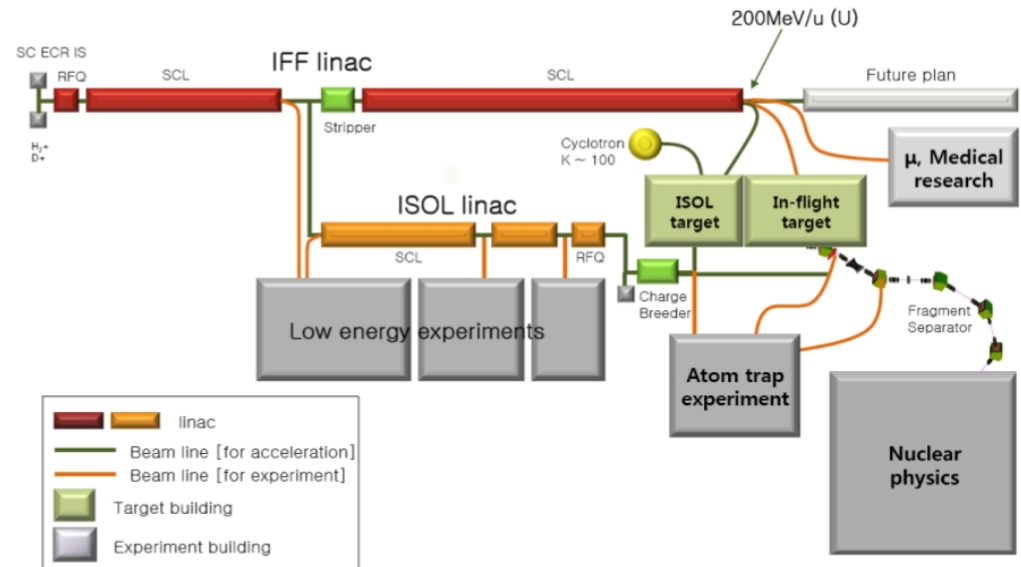

home.skku.edu/~anme



Thu, 16:45-18:00 session

SC LINAC for ISOL RIB

S.W.Shin

A comprehensive design study, SC Linac for KORIA ISOL RIB

Layout of KoRIA Project

Unique Origin
Unique Future

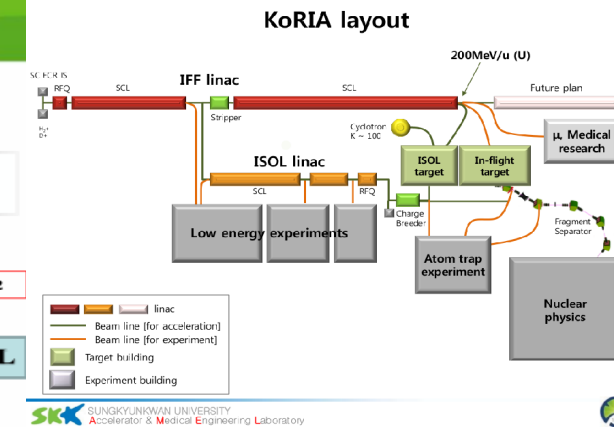
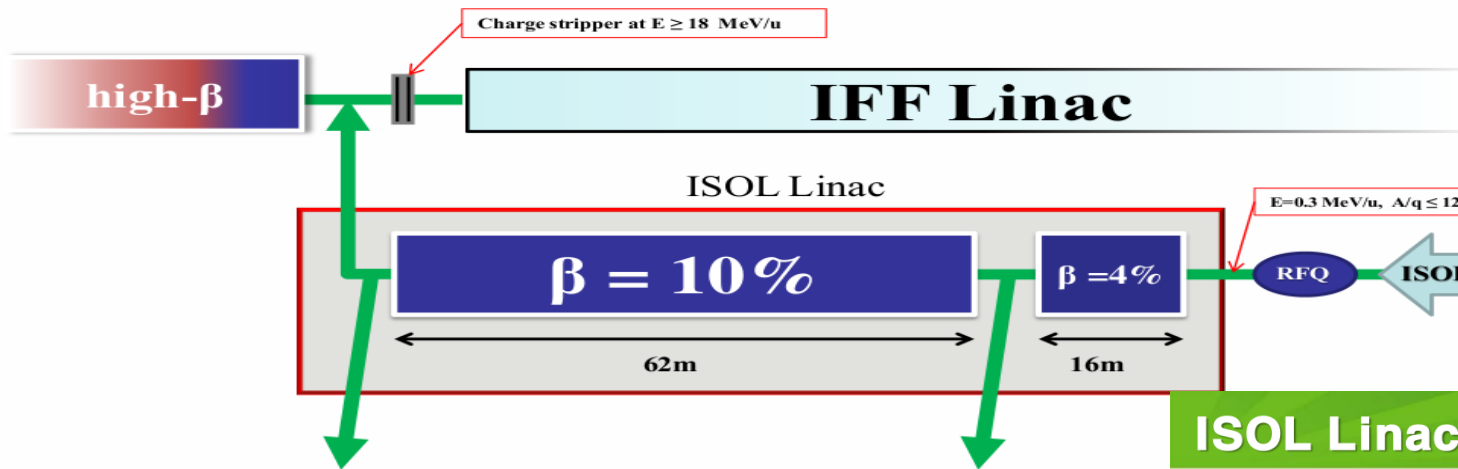

ISOL Linac Details

Unique Origin
Unique Future

High-energy
ISOL experiments

Low-energy
ISOL experiments

- Frequency = 70 MHz
- Energy for charge stripper (of IFF Linac) ≥ 18 MeV/u
- Max. A/q value: 9
- Both CW and pulsed mode
- Consists of
 - ✓ 2 kinds of SC quarter wave resonators (QWRs)
 - ✓ SC solenoids as focusing elements
 - ✓ Operating temperature: $T=4.5$ K



Sat, 9:15, 1st talk



Status of 3GeV- RCS in J-PARC

Michikazu Kinsho
(J-PARC, JAEA)

Contents

1. Introduction : J-PARC RCS, brief history
2. Issues for high power operation
 - ✓ Reduction of beam losses
 - ✓ High beam quality
3. Availability of the beam operation
4. Power up scenario
5. Summary

**J-PARC
(JAEA & KEK)**

Linac
[181 MeV at present,
400 MeV with ACS]

**3 GeV Rapid
Cycling
Synchrotron (RCS)**

**50 GeV Main Ring
Synchrotron (MR)**
[30 GeV in 1st phase]

**Materials &
Life Science
Facility (MLF)**

**Hadron
Experimental
Hall**

**Neutrino Beam Line
to Kamioka**

- JFY 2006 / 2007**
- JFY 2008**
- JFY 2009**

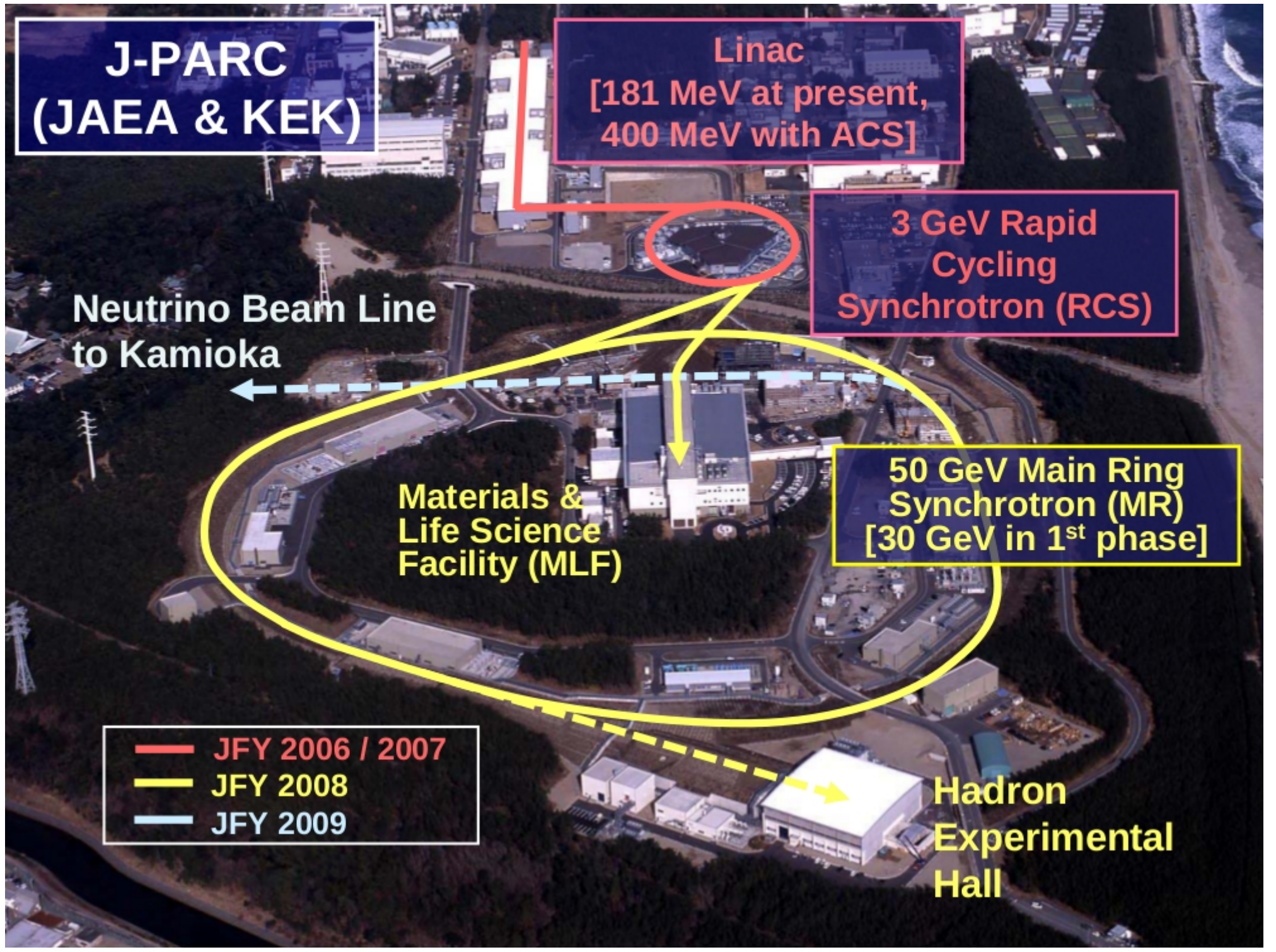



Summary

- We started the MLF user operation in December 2008 with 4 kW output beam power.
 - After the recovery of the RFQ discharge problem, the beam power for MLF was increased to 120 kW in November 2009.
-
- We successfully demonstrated a 300 kW output operation with a low intensity loss of 1% at the RCS by optimizing the painting injection.
-
- After completing the following hardware improvements in this summer maintenance period,
 - vacuum improvement in the SDTL and future ACS section
 - introduction of AC power supplies for chromatic correction sextupoles
 - introduction of a small charge exchange foil
-
- we plan to gradually increase the output beam power,
- 160 kW in December 2010
 - 200 kW in January 2011 . . . and then 300 kW.
-

Sat, 10:00, 2nd talk

J-PARC Main Ring

FFAG10

2010.10.30

KEK Masahito Tomizawa

- OverView
- Slow Extraction Operation
- Fast Extraction Operation
- Beam Power-Up Plan

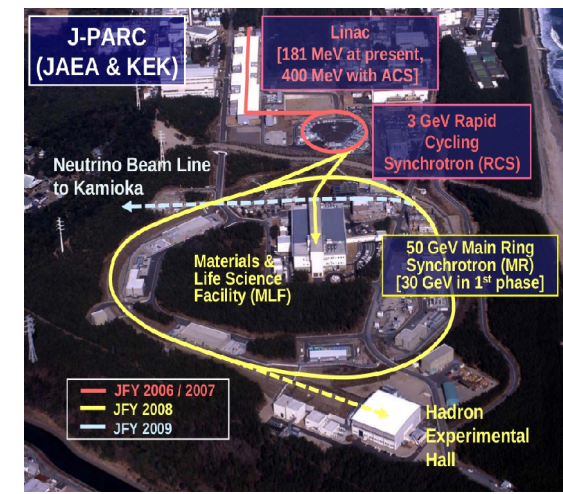

Brief History and Status of MR

History

- May 2008 first beam circulated
- Dec. 2008 first acceleration up to **30 GeV**
- Jan. 2009 first slow extraction to hadron facility
- Mar. 2009 first fast extraction to neutrino facility

Present Status

- 3 kW slow beam (6.0 s) for hadron experiments
- 50-60 kW beam (3.52 s) for neutrino oscillation experiments

Fast Extraction Cycle

3.52 s (present) -> 3.2 s (Nov. 2010) -> **2.6 s** (before summer 2011)

J-PARC is part of the world competition...

Neutrino Oscillation Experiment International Competition

J-PARC MR 3.26×10^{19} POT

SK first event Feb.24, 2010

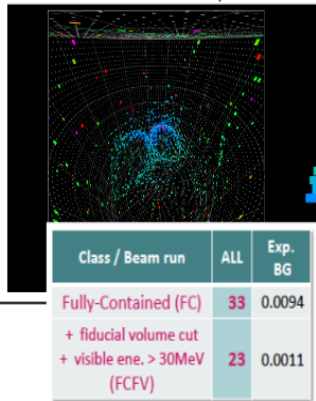

Double CHOOZ

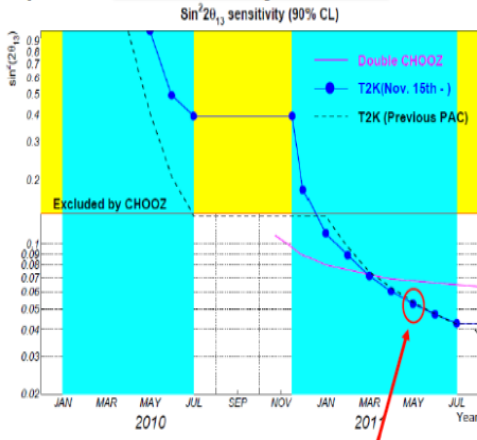

NOvA

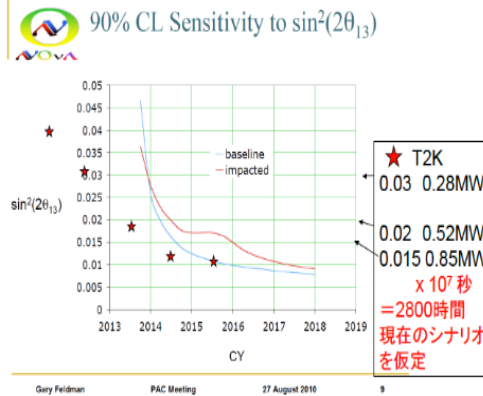

13

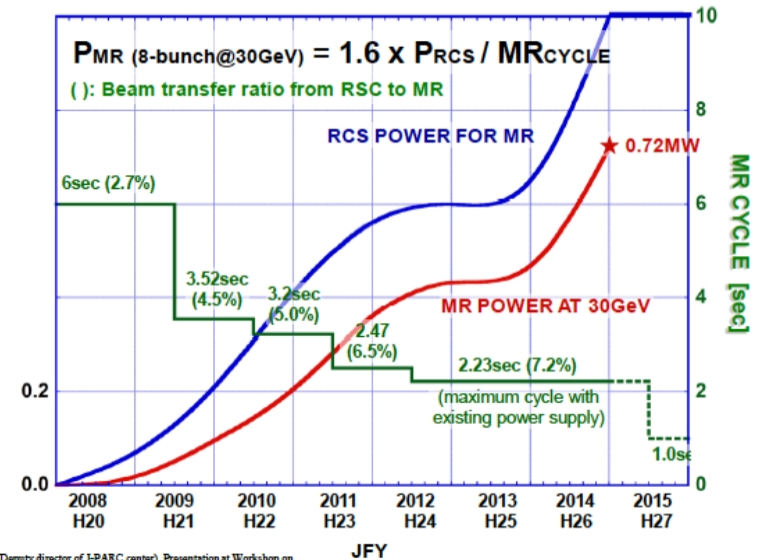

H.Kobayashi (Deputy director of J-PARC center), Presentation at Workshop on Applications of High Intensity Proton Accelerators, Oct.19-21, 2009, FNAL

150 kWx10⁷ s (116days) by Jun 2011
720-750 kW in 2014

Sat, 4th talk

Overview of Kyushu Univ. FFAG Facility

Yujiro Yonemura, Kyushu Univ.

Contents

1. Overview of a new accelerator facility of Kyushu University
2. Construction status
3. Alignment of the main ring
4. Status of hardware development
 - 4-1. RF cavity
 - 4-2. Extraction Kicker (presented by Matsunaga)
 - 4-3. Beam Monitor (presented by Fujinaka, kuratomi)

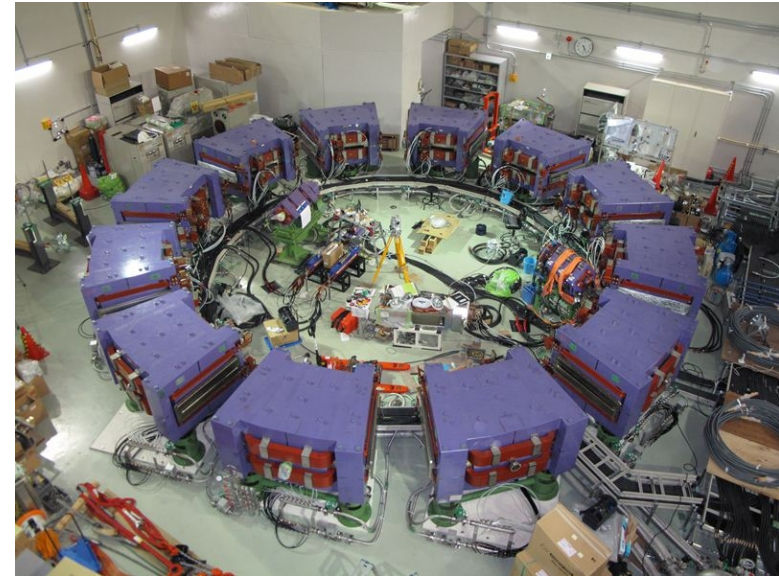

Cabling and Power test
(Jun-Sep 2010)



- Construction of 150 MeV FFAG will be completed by Dec 2010.
- Beam commissioning is scheduled to start in Jan. 2011.
- In order to decrease power dissipation per cavity, the second cavity with new cooling plate has been developed.
- Power test of the second cavity has been performed. Gap voltage of 4.2 kV/cavity has been achieved.

Sat, 11:10, 5th talk

H- injection @ 150MeV KURRI FFAG Kota Okabe, Fukui Univ.

Layout of KURRI-FFAG complex

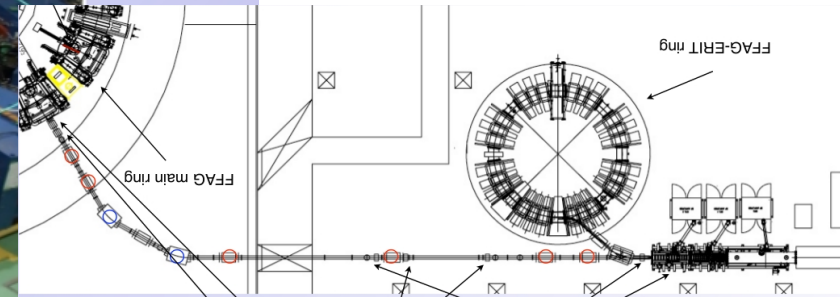
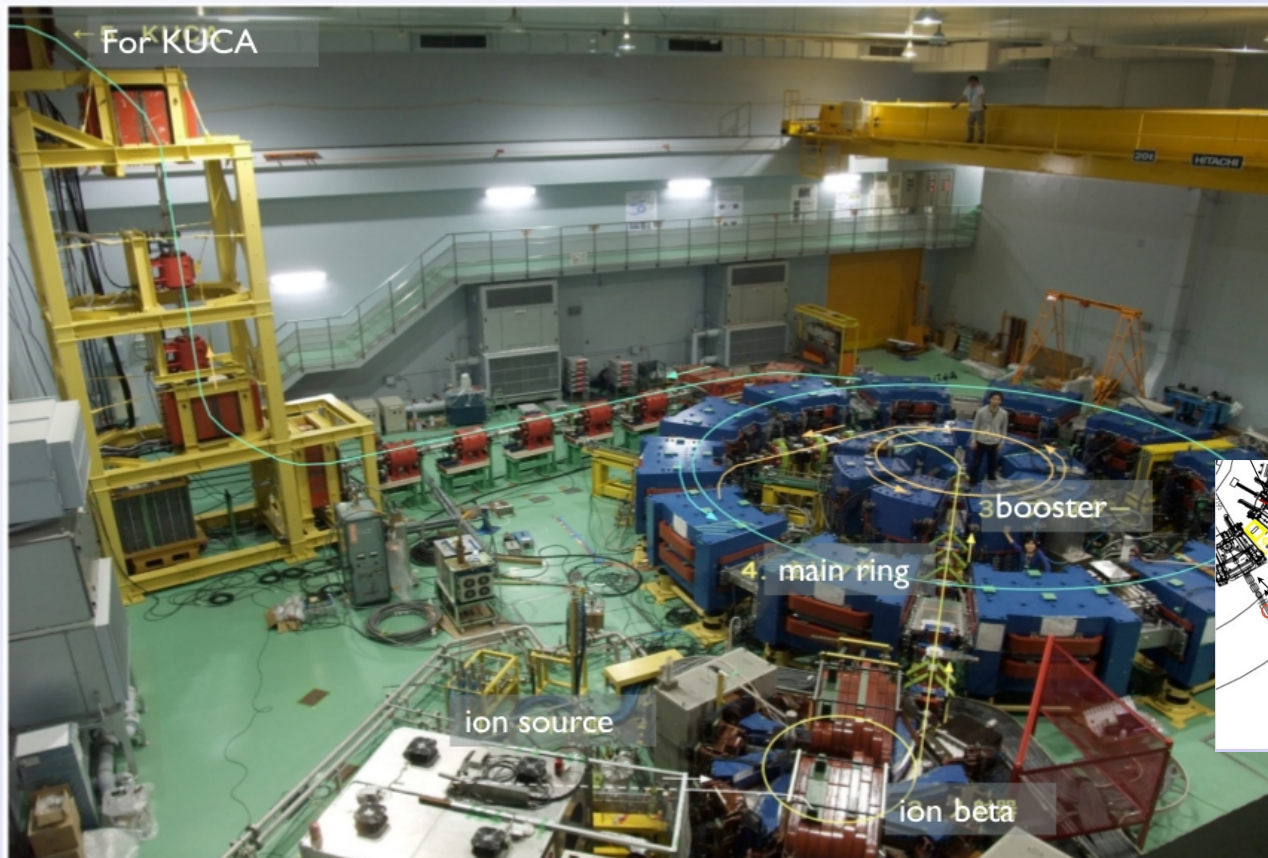

Summary

- Comparison of Injectors
 - Beam intensity
 - Ion-beta & booster(30Hz) $6.0 * 10^8$ [ppp]
 - H-Linac (30Hz) $3.1 * 10^{12}$ [ppp]
 - H-beam from Linac will be injected by charge-exchange injection method.
Designed average current is $1 \mu\text{A}$.(11 turn injection)
 - Maximum current is $15 \mu\text{A}$ with 160 turn injection.
- Injection beam line
 - Beam merging of H- and H+ beam will be performed by main magnets of FFAG.
 - Stripping foil position has decided to be at the center of F-magnet by beam tracking simulation.
 - Beam transport line has designed by SAD.

Sat, 11:50, 6th talk

Industrial Apps of Electron Beams

Takashi Baba, NHV Corp.



500keV Electron FFAG

Energy	250-500keV
Acceleration frequency	10kHz (Induction)
Beam Power	10kW
Outer diameter	1.1m

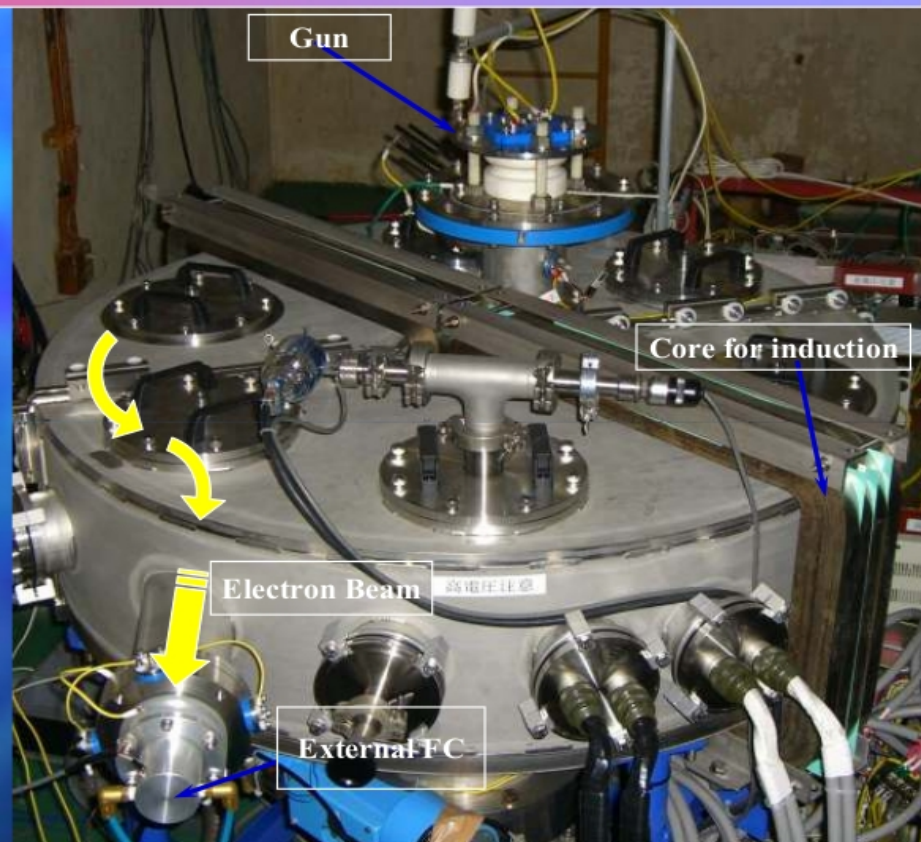
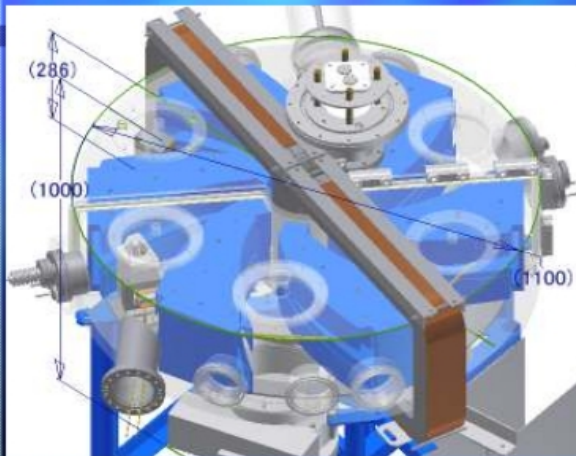

Sat, 13:30

Medical Aspects of PAMELA

Takeichiro Yokoi, JAI

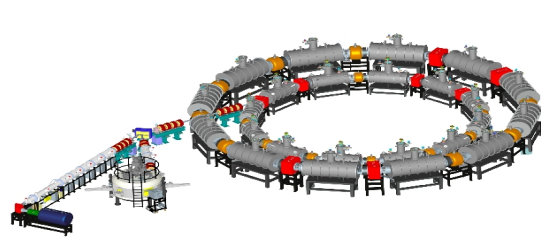

Some challenging rules in view of uniformity of dose delivery

- For the application of FFAG to particle therapy, beam control is crucially important (beam position, beam intensity)
- The repetition rate is key issue for pulsed medical machine. (~1kHz)
- Flexible and precise intensity control must be implemented (dynamic range >30, precision <2%)
- LINAC would be more suitable for injector rather than cyclotron
- Newly developed machine should take into account the capacity of rescanning
- Beam position strongly influences to the treatment quality, efficiency
⇒ Orbit correction system in transport line is a requirement
- FFAG transport-gantry still needs time to mature (size, steering, switching etc)
⇒ At the moment, conventional transport + gantry is also considered as an option in PAMELA. Extraction section can cope with both of them)

Sat, 14:10

Beta-Beams & RI Production Ring

Elena Benedetto, CERN

Beta-Beams: the idea

- Aim: production of electron (anti-)neutrino beams from β -decay of radioactive ions circulating in a storage ring
(P. Zucchelli, Phys. Let. B, 532 (2002)166-172)

- **Produce** radio-isotopes
- **Accelerate** them
- **Store** in Decay Ring (DR)
- **Let them β -decay** (a straight section points to detector)

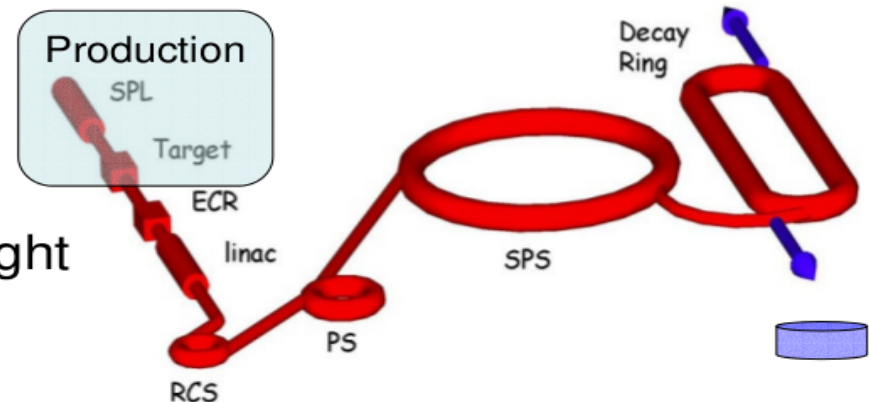

- **Pure ν_e /anti- ν_e** are emitted (need a pair of β^+/β^- emitters)
 - with a known energy spectrum ($E_\nu \sim 2\gamma Q$)
 - in forward direction, (cone $\theta < 1/\gamma$)

$Q = \text{Reaction Energy} \sim \text{few MeV}$

Summary

- **BetaBeams:**

- electron (anti-)neutrino beams from β -decay of radioactive ions, for oscillation experiments
- Challenges due to high intensity beams

- **Production Ring for Li, B**

- Uses internal target & ionization cooling
- Preliminary design, tracking exist
- Still a lot of R&D for a feasible solution (enough flux)
 - e.g. Existing gas-jet targets cannot reach the densities proposed in [C.Rubbia, *et. al*] in a vacuum environment
- Liquid lithium target and D/³He beam may be the solution, studies started
- Here to investigate use of ERIT-type FFAG to produce Li, B
- **BUT: first priority find feasible solution for target!!!**

Sat, 14:45

700 MeV Spiral Ring for KURRI

Bin Qin, KURRI

- Preliminary design of a spiral-sector FFAG upgrade ring (150MeV ~ 700MeV) for neutron source
 - Lattice parameters search
 - TOSCA model study
 - tune shift control
 - acceptance survey
- Next...
 - Optimization on tune shift
 - Longitudinal tracking
 - Design for injection / extraction

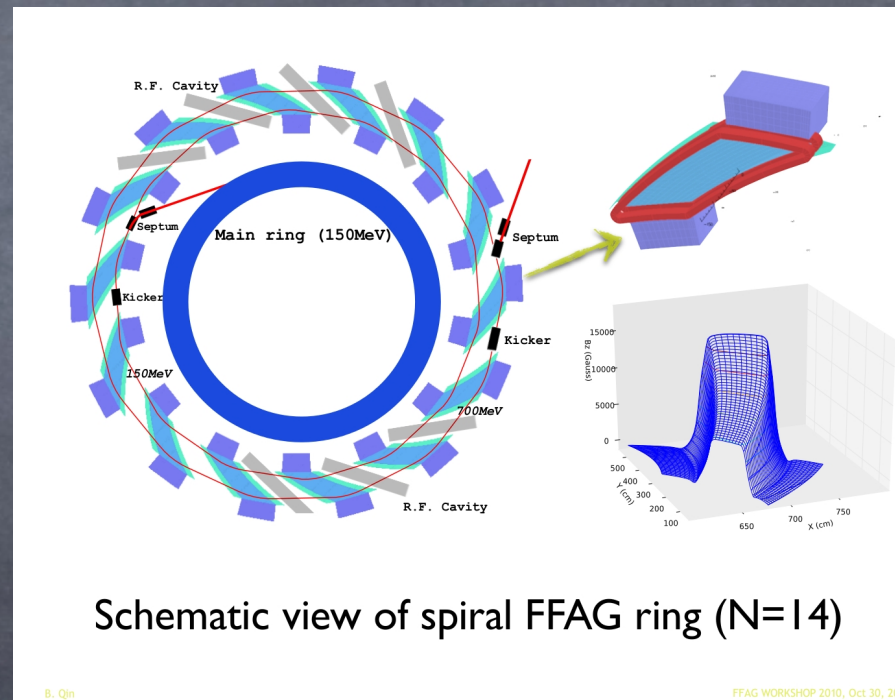

Schematic view of spiral FFAG ring (N=14)

Sat, 15:20

Kicker magnet for Kyushu FFAG

Takachi Matsunaga

Motivation : reduce beam loss

Means : fast kicker (<150ns)

Development of kicker(1)



This is the kicker developed at Kyushu University.

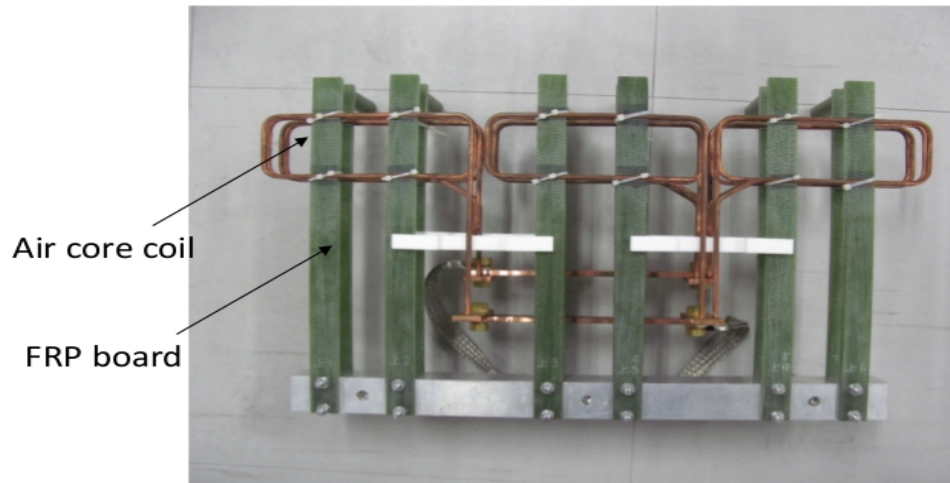

The three divided air core coil is connected in parallel.

Each coil is supported by FRP board.

Measured inductance is **0.95 μ H**.

Sat, 15:45

BPM for 150MeV FFAG

Tatsuya Fujinaka, Kyushu Univ.

Developed five electrodes beam monitor

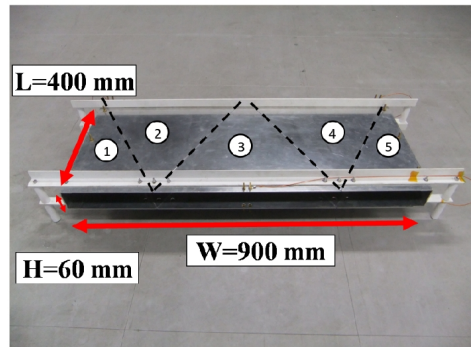

Summary

We have developed five split electrodes beam monitor, and measured position response of the monitor.

From the experiments, we have improved the position conversion formula taking into account the effect of electric field leakage.

Resolution: about 0.5 mm

We have been analyzing the electric field leakage.  Next presentation

We will install the developed monitor to the 150 MeV FFAG and utilize it for beam commissioning.



Sat, 16:10

BPM for 150MeV FFAG

Shogo Kuratomi, Kyushu Univ.

Analysis of electric field leakage

I am trying to reproduce the result of the experiment by the analysis software.

Analysis type... Electrostatic analysis

Actually, a field around the monitor is **not** an electrostatic field because beam is circulating. But an electrostatic analysis is enough because pick-up voltage of electrodes is thought to be proportional to electric field strength on the electrode surface.

Analysis software...TOSCA(Opera-3d).

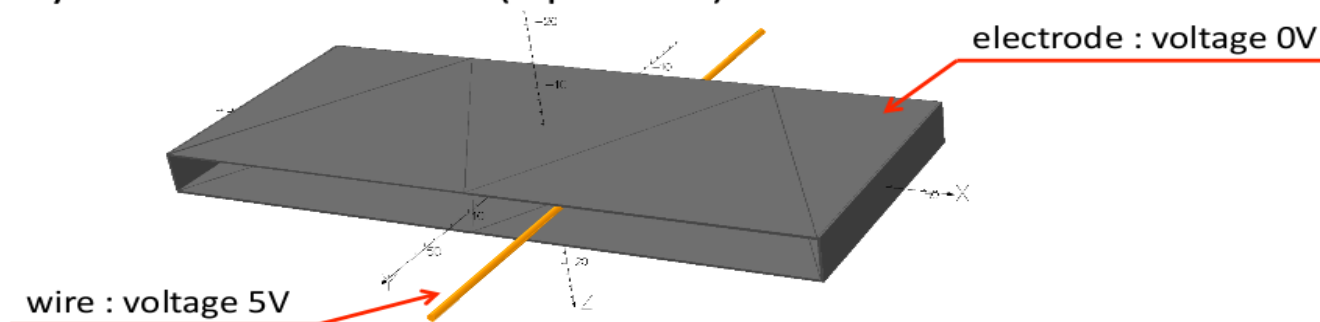

Model and Condition of this analysis

Sat, 16:15

Development of Charge-Exchange Foil

Yusuke Niwa

For stripping H- injection into KUCA 150MeV FFAG

CONTENTS

- 1 Background of study
- 2 New injection line of Kyoto University FFAG accelerator
- 3 Charge-exchange efficiency and Energy Loss of the carbon foil
- 4 Heat characteristic of the carbon foil
- 5 Structure of the carbon foil
- 6 Fabrication method of the carbon foil
- 7 Summary

We have succeed to fabricate wire less carbon foil

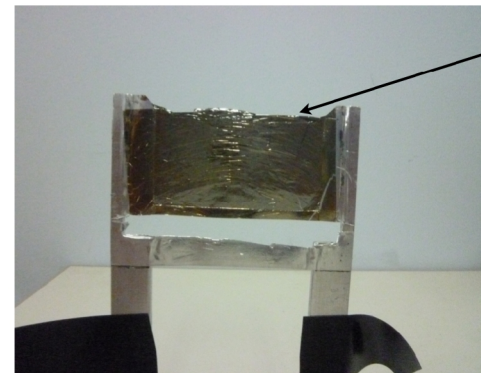

It is not necessary to cut by the cutter

Figure 8 thickness $20\mu\text{g}/\text{cm}^2$ of the carbon foil

Sat, 16:20

Serpentine Acceleration in Zero-Chromatic FFAG With Long Straight-Section

E. Yamakawa

- Motivation of this study
- Longitudinal hamiltonian in Zero-chromatic FFAG
- Serpentine acceleration in Zero-chromatic FFAG
- Design idea of accelerator scheme with long straight section in non-Zero chromatic FFAG
- Summary

One candidate of design

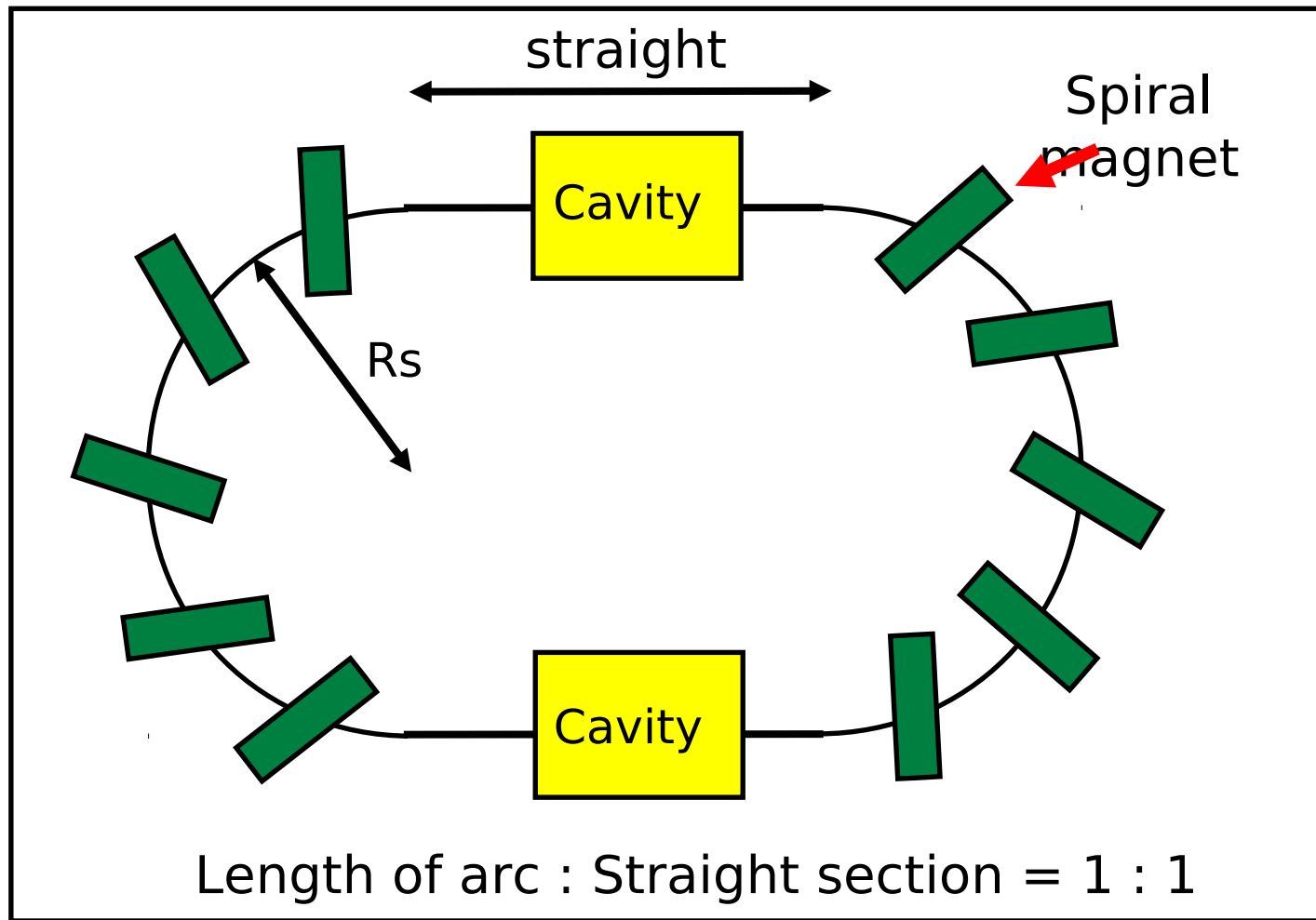

To make a small ring...

Large magnetic field is needed $B\rho = 5.4[Tm]@\gamma = 2$

Using SC spiral FFAG magnet in the arc part

Sat, 16:45

Superferric SC scheme Using spiral FFAG for Carbon Therapy

Bin Qin, KURRI

Motivation: carbon therapy

- Larger biological effect compared with protons/X ray, more efficient against hypoxic and radioresistant tumors
- Carbon requires much more B-rho compared with proton: 25cm depth tissue, 200MeV proton , but 375MeV/u for carbon, factor of magnetic rigidity 2.85
- Advantage of FFAGs for carbon therapy:
 - ✓ Variable energy (vs. cyclotron)
 - ✓ Strong focusing, leads to small beam size (vs. cyclotron)
 - ✓ High repetition pulse beam, suitable for spot scanning (vs. synchrotron)
 - ✓ Simplicity and easy for operation (vs. synchrotron)
 - ✓ Smaller excursion due to high field gradient (vs. cyclotron)

High field spiral C^{6+} FFAG ring using superferric superconducting magnet

Basic parameters

Injector	Cyclotron or Linac (50keV/u ~ 12MeV/u)
Injection energy / Bp	12 MeV/u , 1.0 T.m
Extraction energy / Bp	400MeV/u, 6.36 T.m
Momentum ratio	6.36
field index	6.0
Bz @ R _{ext}	5.0 T
packing factor	0.42
R _{ext}	3.03m
R _{inj}	2.33m
Radius excursion	0.7m
lattice	14 cell, spiral sector
spiral angle	57 deg.
cell tune	Q _x =0.2, Q _y =0.13

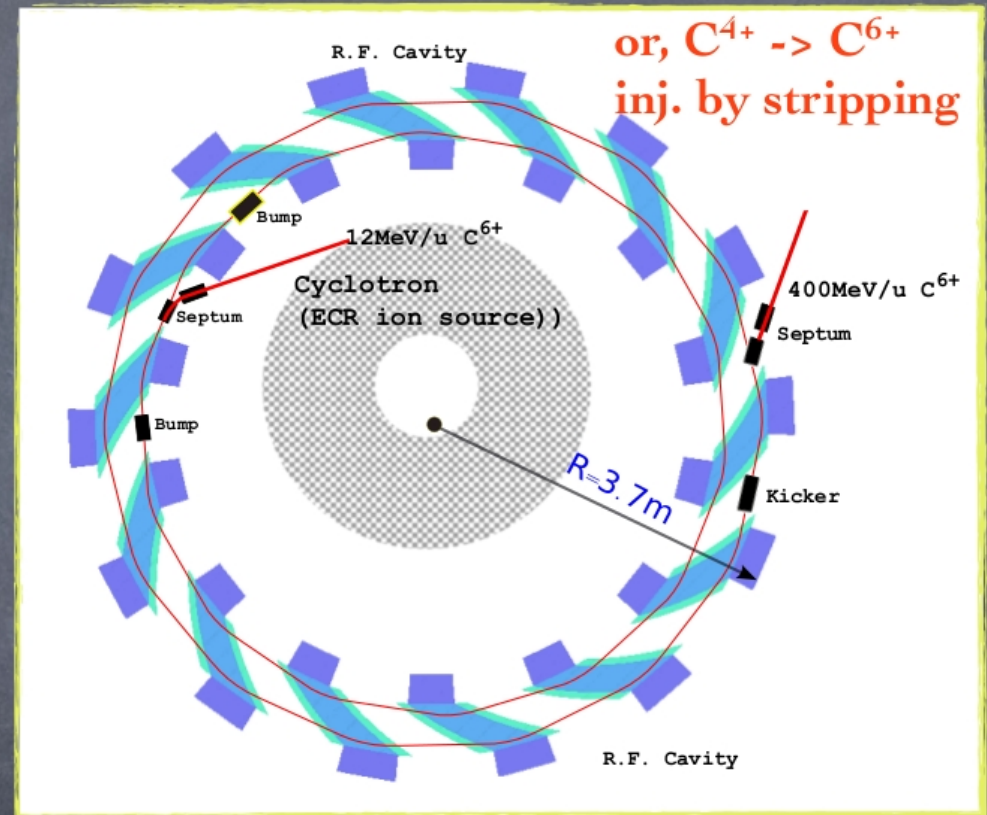

Schematic plan of the carbon therapy machine: (Cyclotron injector + Superconducting spiral FFAG ring)

A superferric SC dipole

Optimized model with variable Gd layer height

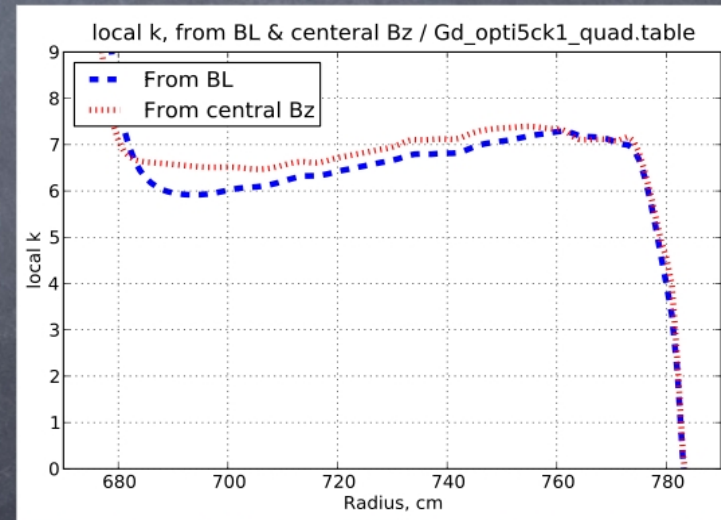
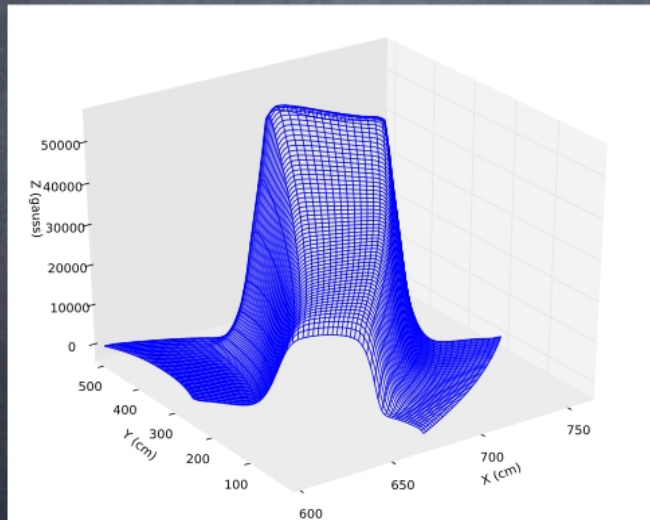
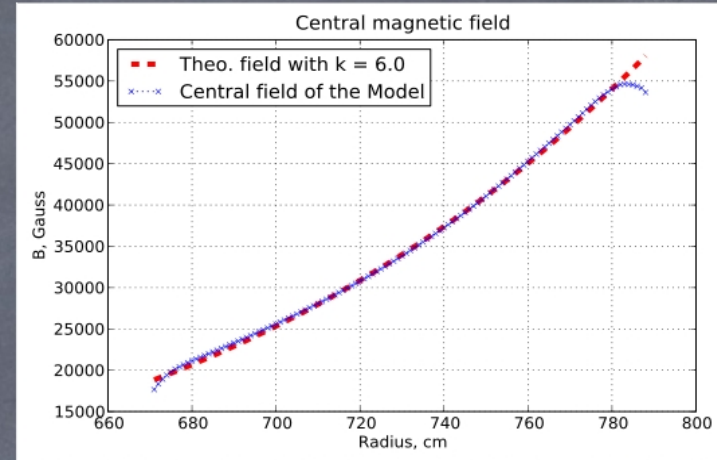
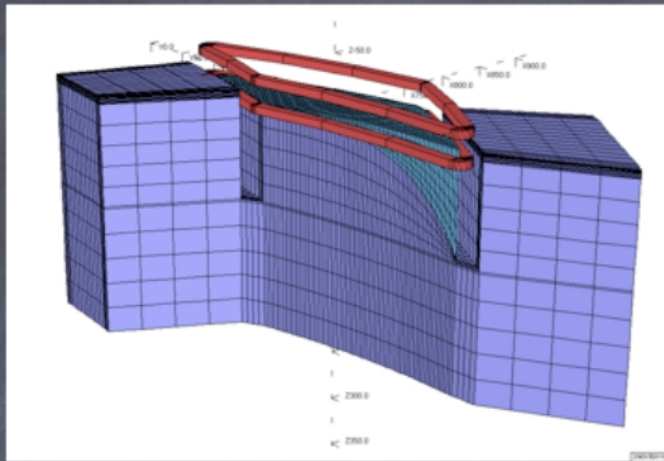

IT'S POSSIBLE FOR $B_{MAX}=5T$ @ $k=6.0$!

Summary

- A very rough idea for compact superconducting scaling ftag ring
- Feasibility study for high magnetic field combing with high field index
- Simpleness compared with combined function superconducting scheme

Sat, 17:15

What About the Front-End ?

Ciprian Plostinar

?

Sat, 17:45

Progress on PRISM

Jaroslav Pasternak

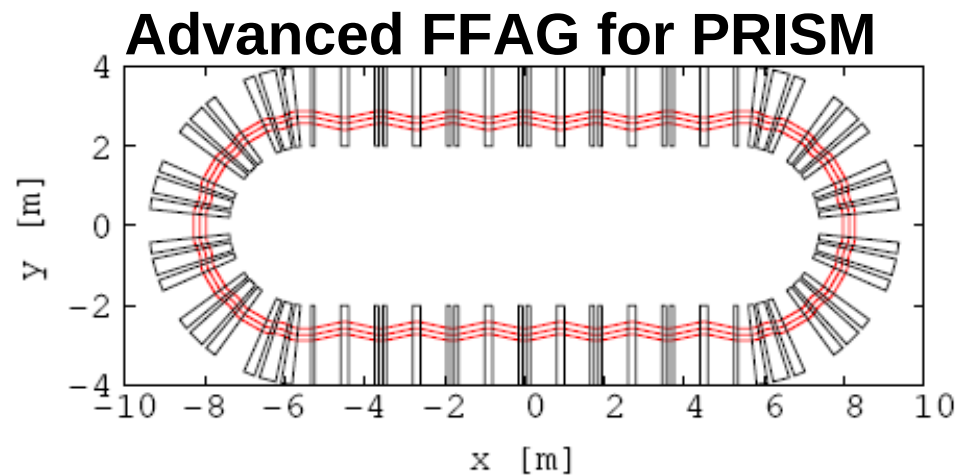
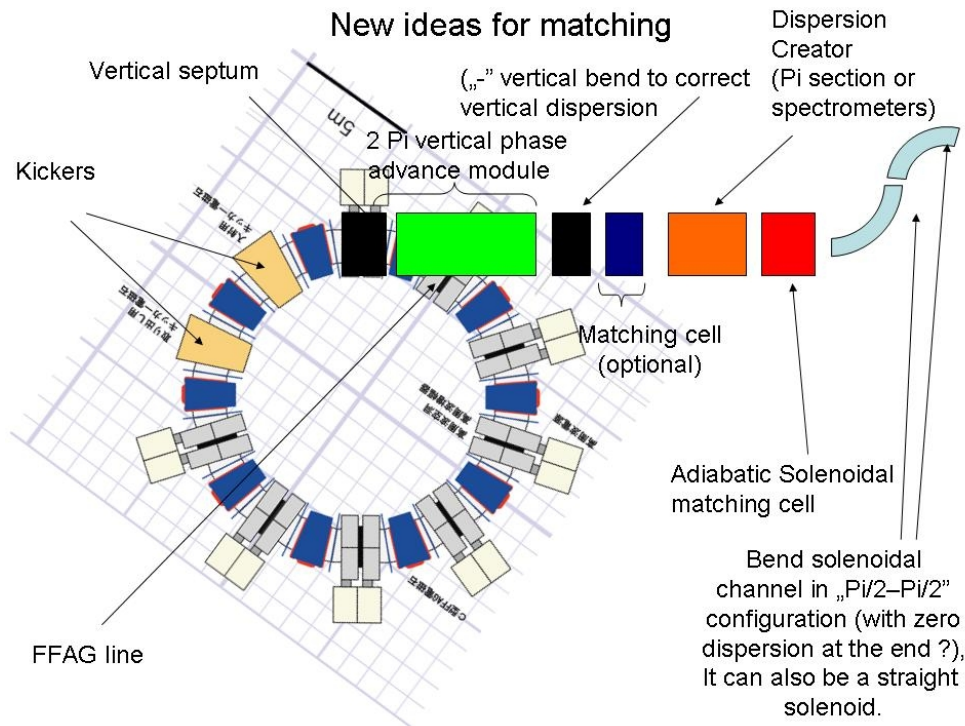

- PRISM Task Force is producing an interesting results:
 - alternative FFAG designs with new characteristics,
 - FFAG type beamline designs,
 - hardware studies (RF and kicker).
- Injection/extraction and the matching to a solenoidal channel are central problems and their solution is essential for PRISM.