

Stripping Foil Studies at 3GeV RCS in J-PARC

Masahiro Yoshimoto*, P.K. Saha, Yoshio Yamazaki,
Naoki Hayashi, Kazami Yamamoto, Riuji Saeki, Hideaki Hotchi,
Hiroyuki Harada, Masato Kawase, Michikazu Kinsho

JAEA/J-PARC, Tokai-Mura, Naka-Gun, Ibaraki-Ken, JAPAN

Isao Sugai, Yoshiro Irie

KEK/J-PARC, Tsukuba, Ibaraki-Ken, JAPAN

- H⁻ injection scheme at 3GeV RCS
- HBC foils
- Foil Experiments
- Long-term follow-up
- Recent foil studies
- Summary

● injection scheme in the RCS

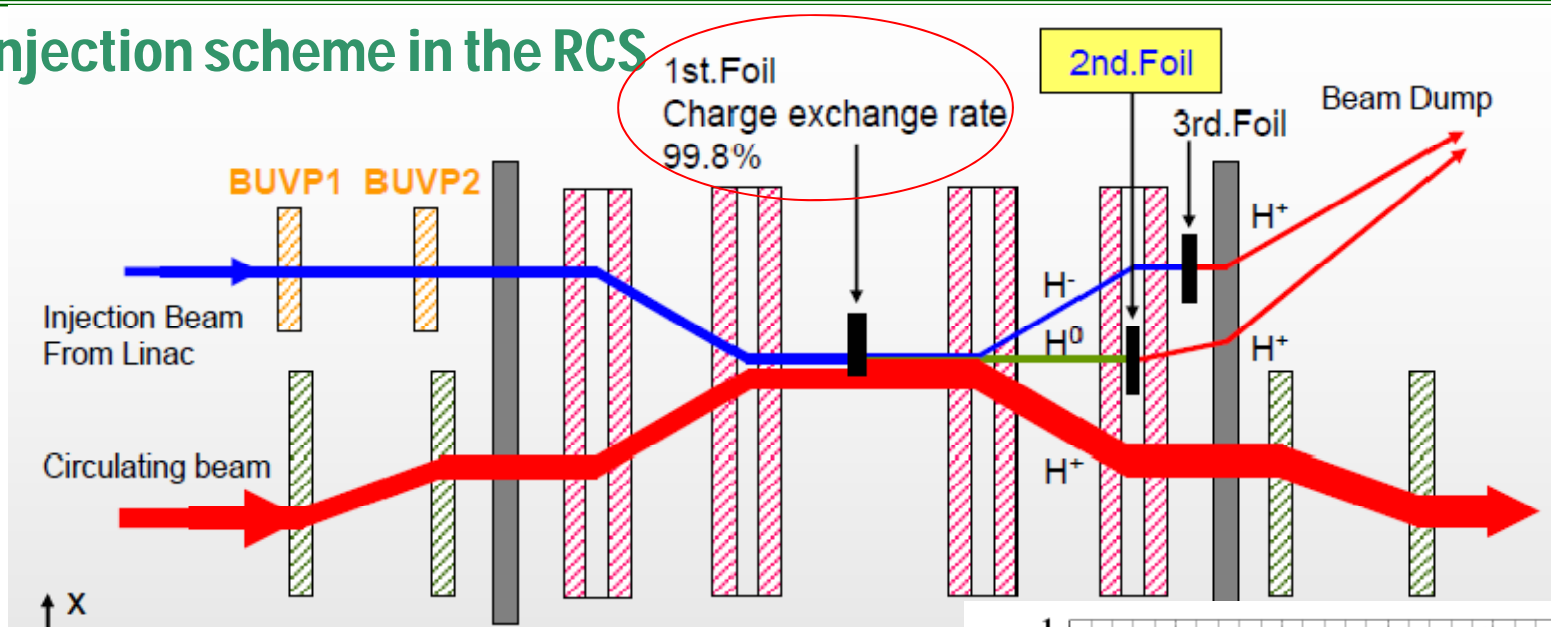

- The RCS has three stripping foils for the beam injection.
- The H⁻ beam from the LINAC is injected into the RCS ring and the charge is exchanged from H⁻ to H⁺ with a 1st charge stripping foil.
- But it is difficult for the H⁻ beam to be charge exchanged perfectly at the thin foil, and the H⁻ and H⁰ beam are occurred exiguously.
- In order to control the H⁻ and H⁰ beam, there are two more stripping foils installed downstream of the 1st foil.
- At the 2nd and 3rd foil, the H⁻ beam and H⁰ beam are exchanged to the H⁺ beam again respectively.

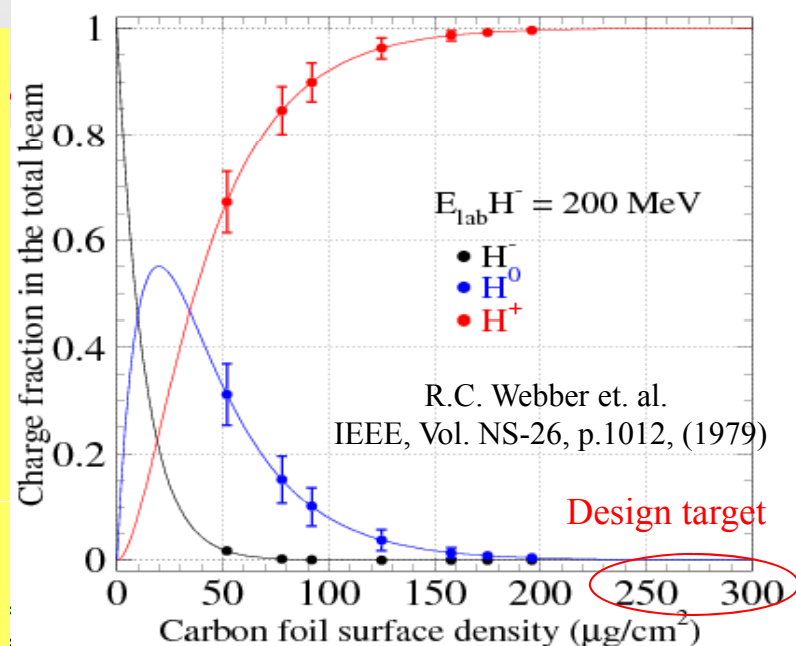

Injection area in the RCS

● Injection area in the RCS

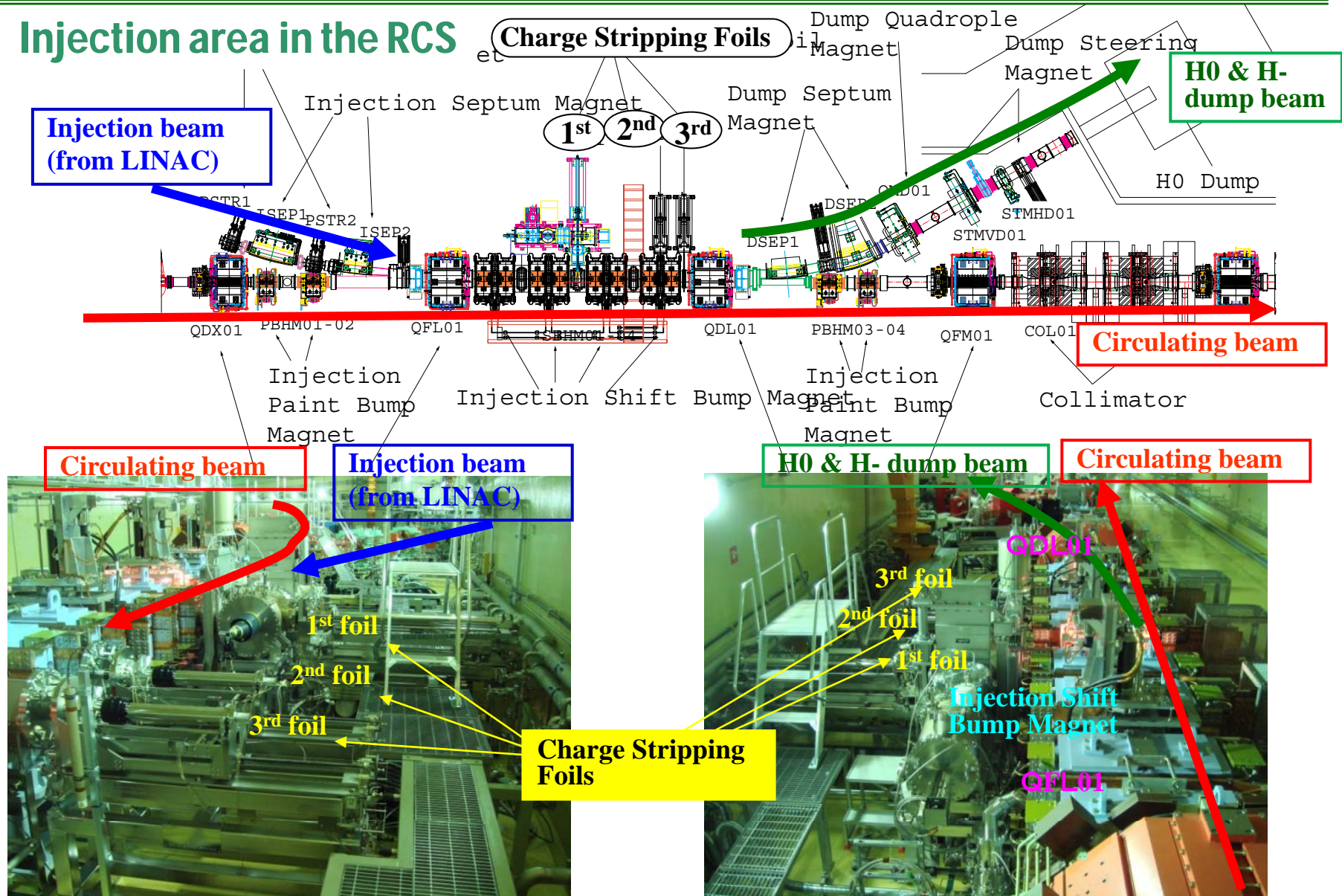

● Scheme of the foil exchange system

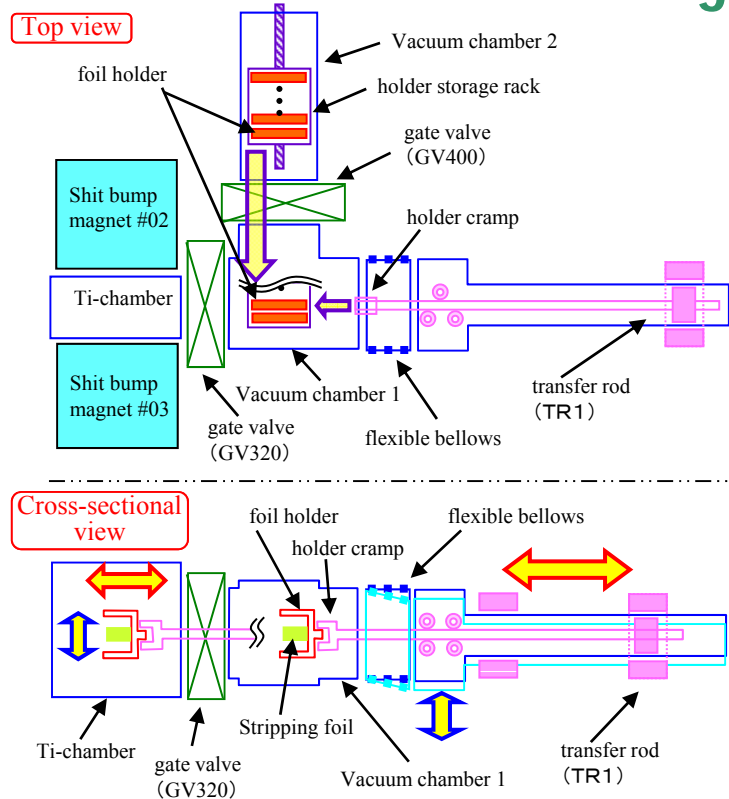

● Foil Exchange System

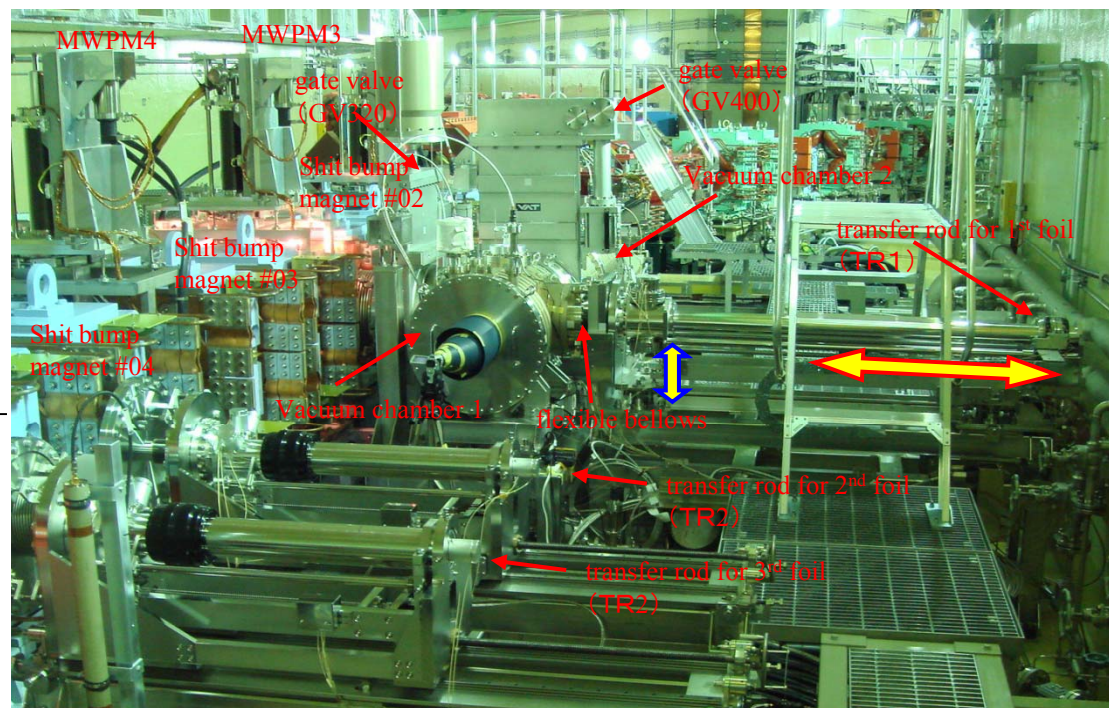

● Requirement:

- The foil position can be adjusted to the both horizontal and vertical irradiated beam spot remotely.
- The broken foil can be replaced with the spare one in vacuum remotely and automatically.

● Design concept:

1. The stripping foil is mounted on the foil holder.
2. The foil holder can be clamped and moved by the transfer rod remotely.
3. The 14 spare foil holders are set on the storage rack and installed on the stock chamber.(vacuum chamber 2).
4. When the foil is broken, the foil holder is replaced with the spare one by the transfer rod.

RCS HBC foils

HBC stripping foil

- The HBC (Hybrid type thick Boron-doped Carbon) stripping foil are developed by Sugai group in KEK, which were improved drastically the lifetime.

foil mounting

Normal mounting

- One edge of a ribbon type HBC stripping foil of 40mm x 110mm is supported by a C-shaped Al holder and the other edge is sandwiched by 10 μ m diameter SiC fiber.

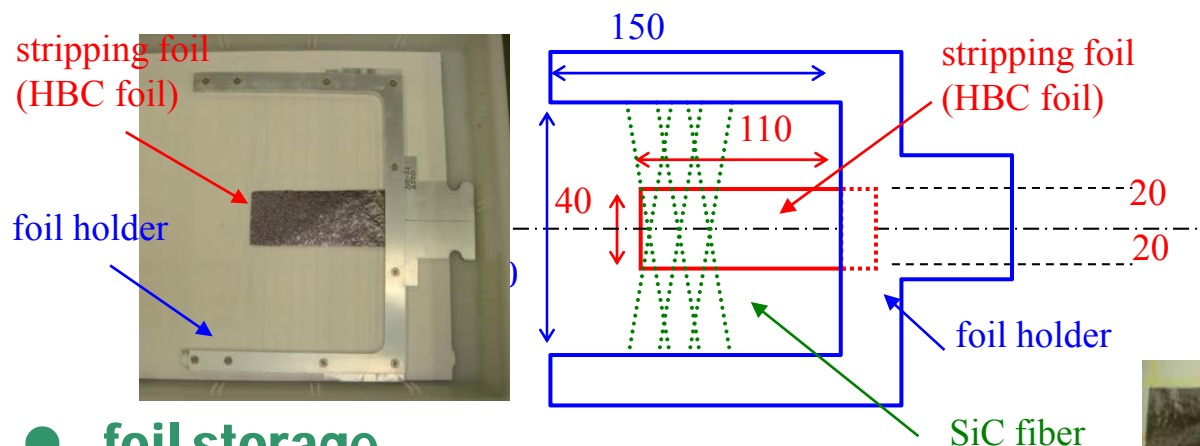

Foil storage rack

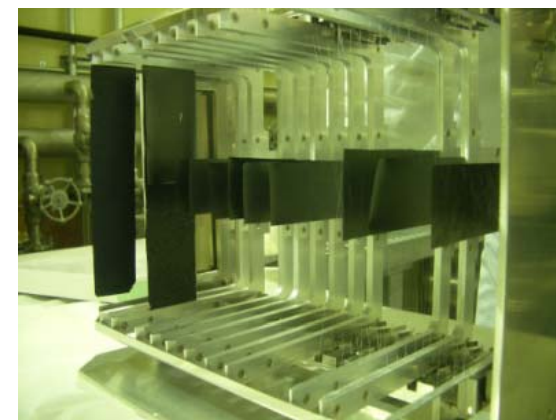

foil storage

- In order to examine the characteristics of the HBC foils, especially in focusing on the foil scattering beam loss, the various foils were installed for beam studies on October 2009 and the beam studies with these foils were carried out.

Normal mounting

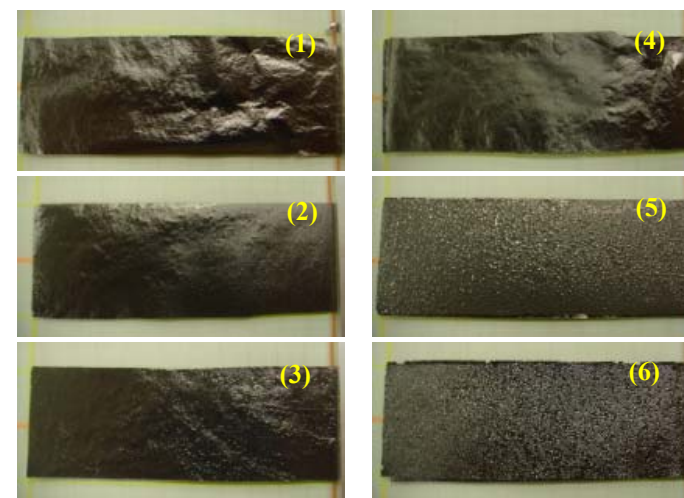

	Foil thickness [μ g/cm ²]					
Normal mounting	(1)	(2)	(3)	(4)	(5)	(6)
	92	196	288	392	487	634

● foil scanning

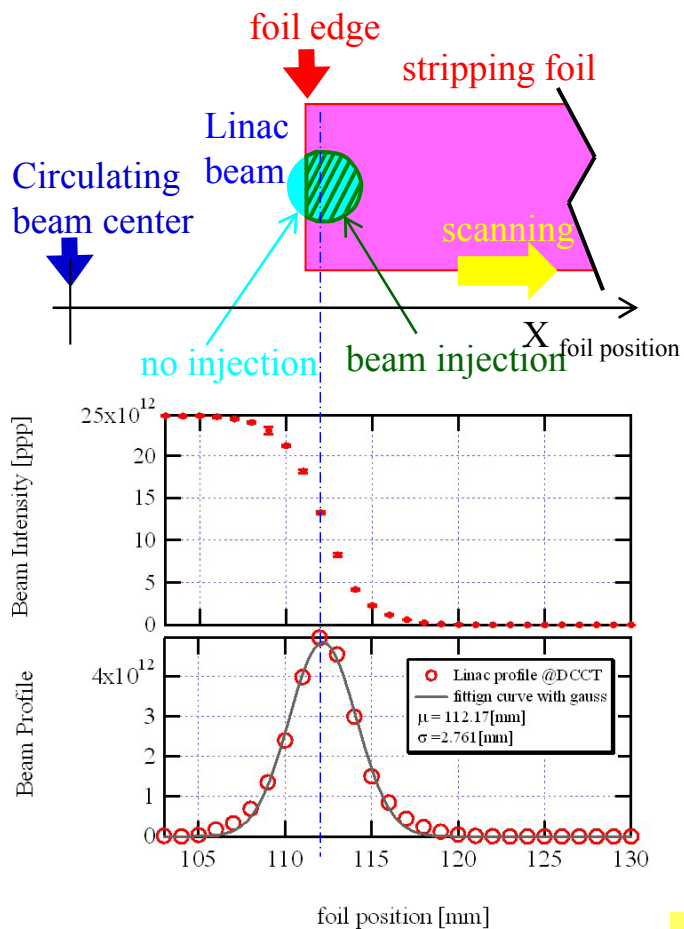

- The beam irradiated spot at the foil was measured by scanning the foil setting position.

● thickness uniformity

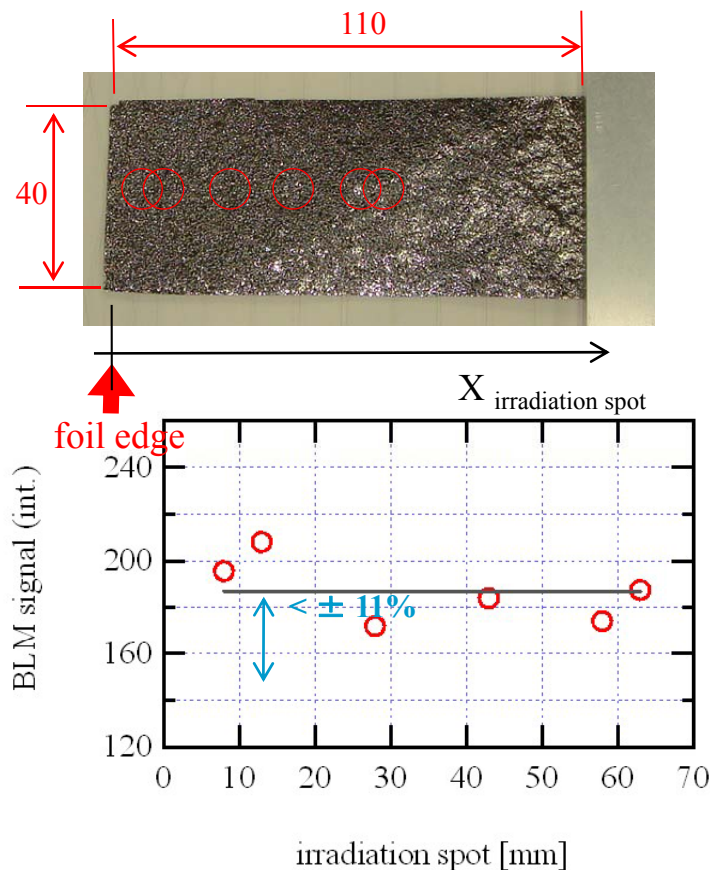

- Thickness uniformity of the HBC foil was estimated from the beam loss caused by the foil scattering.
- Error of the thickness uniformity is found to be kept within +/- 11% along a scanning range of 70mm.

● Beam survival rate with foil thickness

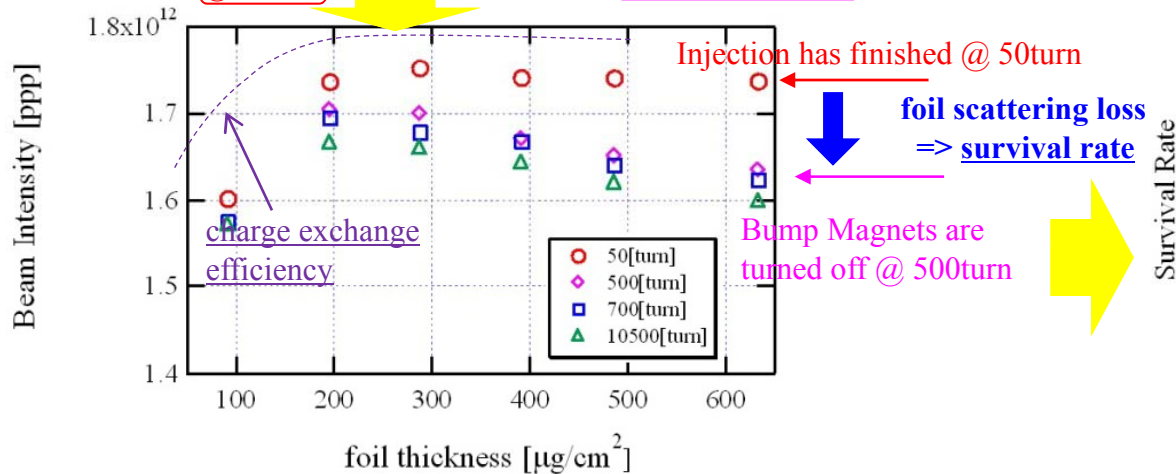
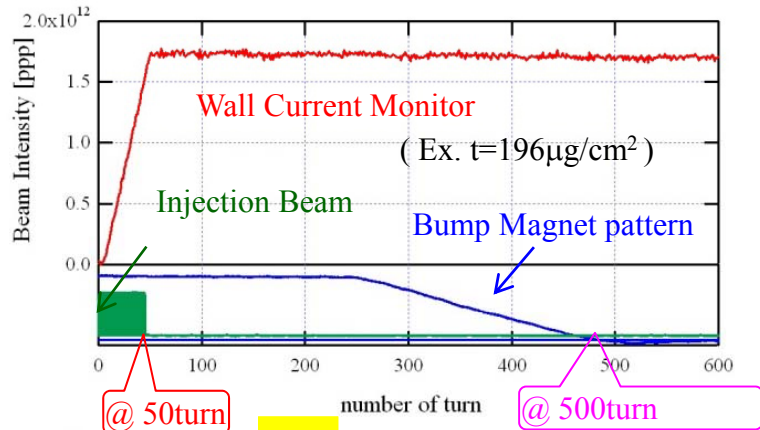

Various thickness stripping foil

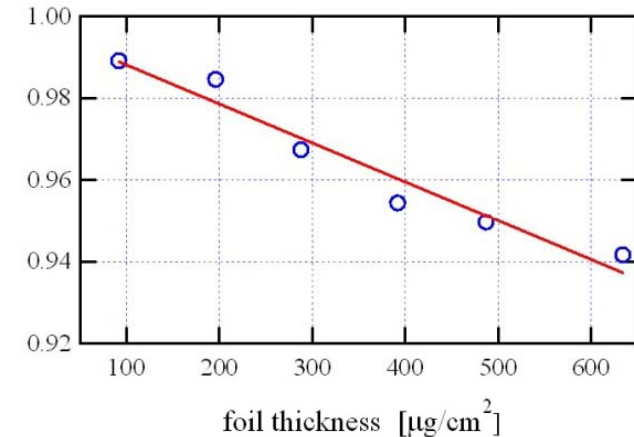
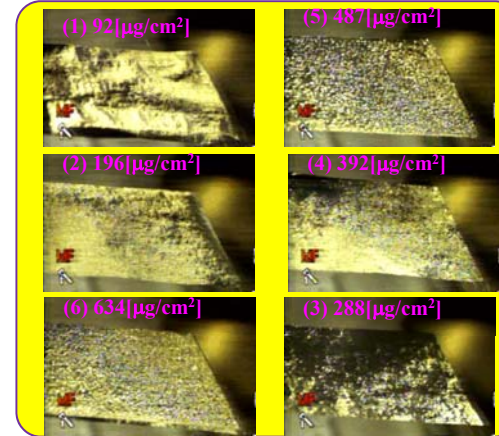

- Thus the charge exchange efficiency was saturated with the foil thickness around $250\text{mg}/\text{cm}^2$.
- Beam survival rate, obtained from the ratio of the beam intensity at 500turn to the beam intensity at 50turn, was proportioned to the foil thickness.

Long-term Follow-up [1]

Total irradiation particles / RUN

($2.09e+19$ [p]) ($1.85e+20$ [p]) ($2.24e+20$ [p]) ($2.24e+20$ [p]) ($2.00e+18$ [p]) ($2.92e+18$ [p]) ($4.12e+19$ [p]) ($4.01e+20$ [p]) ($3.12e+20$ [p])

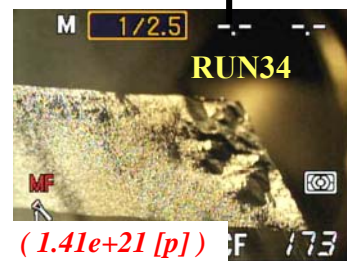
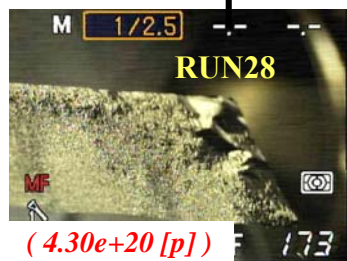
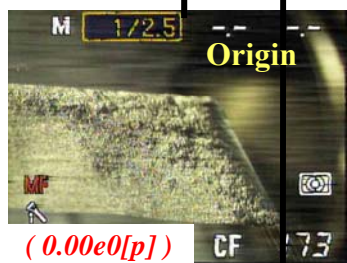
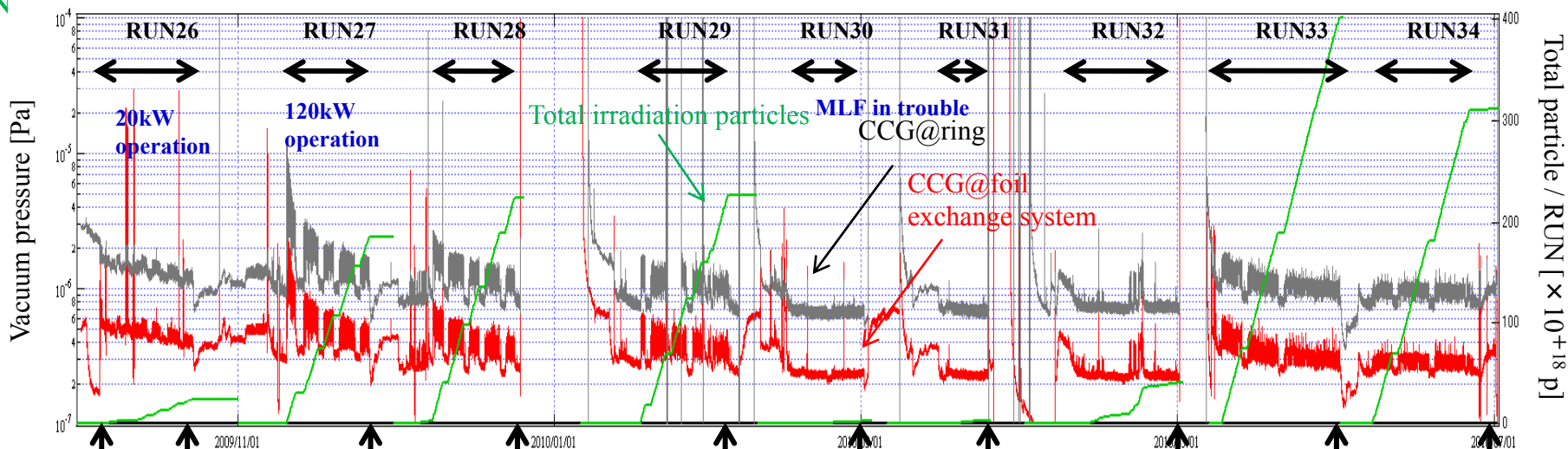

Long-term Follow-up [2]

Total irradiation particles / RUN

($2.09e+19$ [p]) ($1.85e+20$ [p]) ($2.24e+20$ [p]) ($2.24e+20$ [p]) ($2.00e+18$ [p]) ($2.92e+18$ [p]) ($4.12e+19$ [p]) ($4.01e+20$ [p]) ($3.12e+20$ [p])

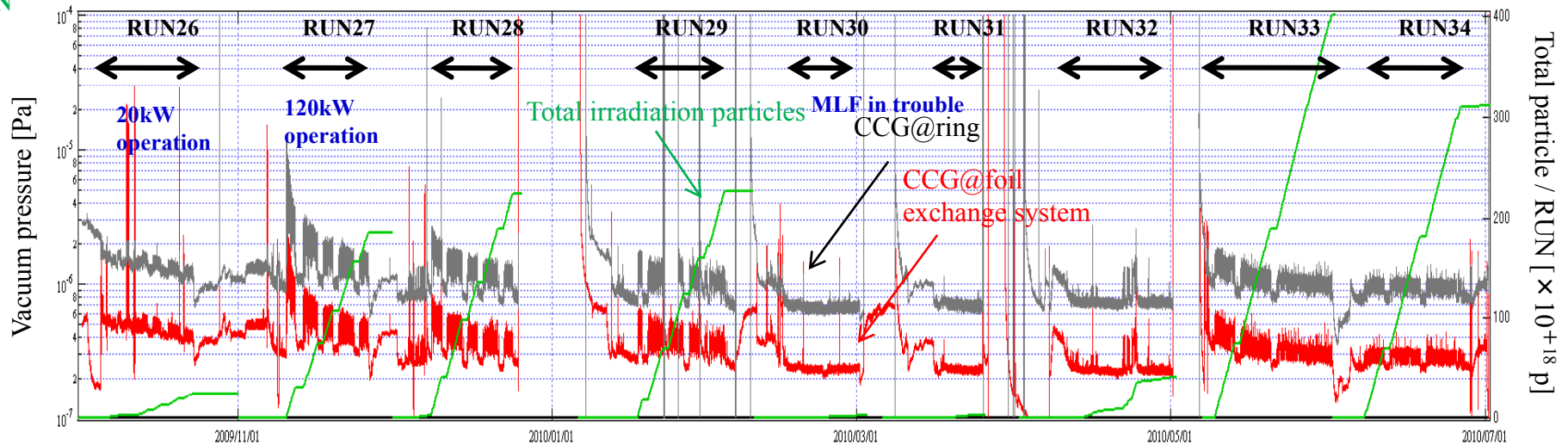

● trend of vacuum pressure

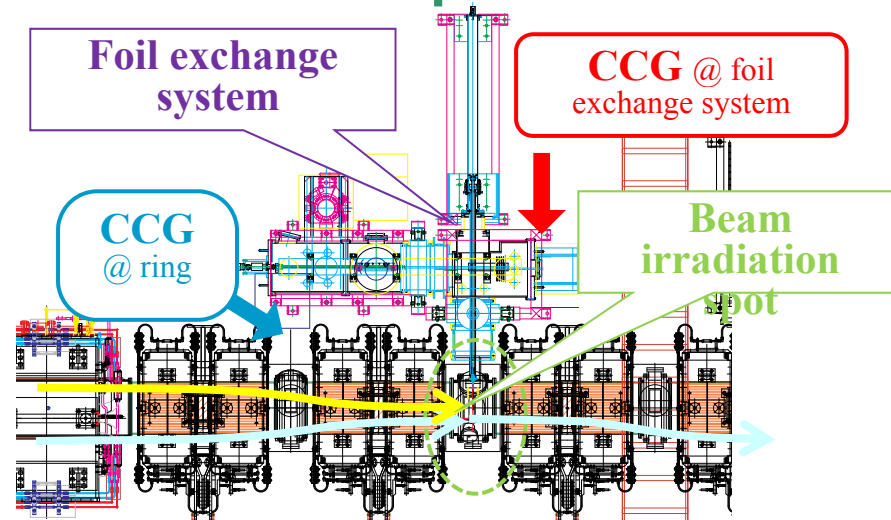

- The beam irradiation to the new stripping foil with thickness of 196mg/cm^2 was started since RUN26 on October 2009.
- Upper graph shows the trend of the vacuum pressure around the HBC foil, and total irradiation particle in every run cycle.
- The outgassing from the HBC foil was decreased and it seems to be stable after the RUN29, and afterward, the outgassing rate from the foil was stable.

● foil deformation

- Foil deformation was varied quickly until 6.54×10^{20} p irradiation, and afterward, it seems the process of the foil deformation has stopped.
- Even after about 1.41×10^{21} p irradiation, no noticeable deterioration of the stripping foils could be seen.

Beam irradiation spot

@ user operation

@ beam experiment

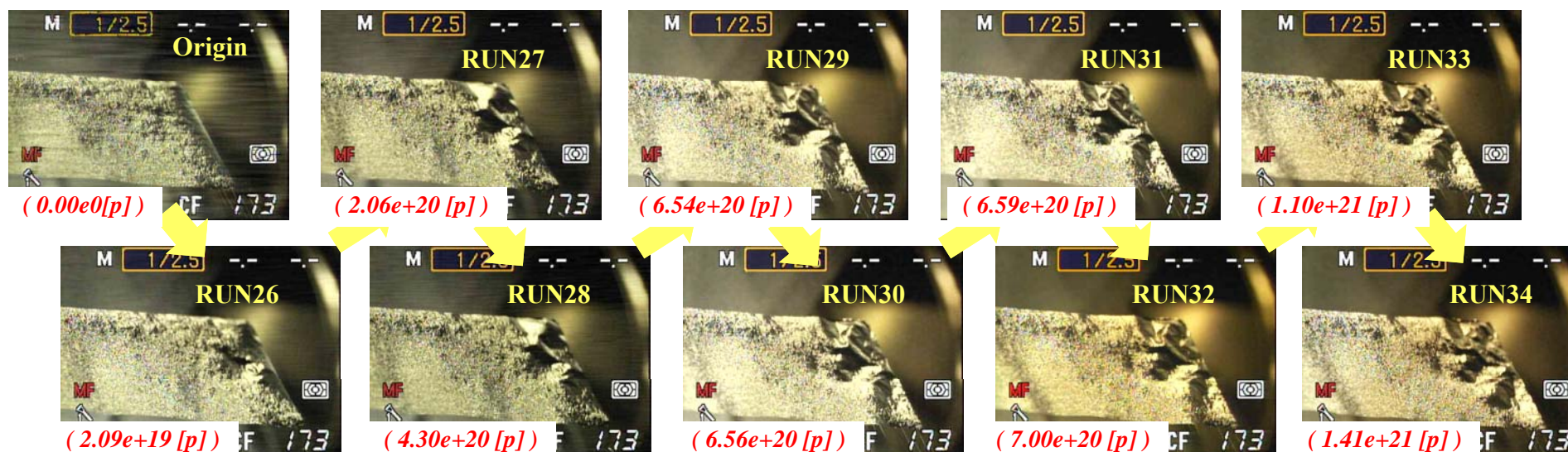
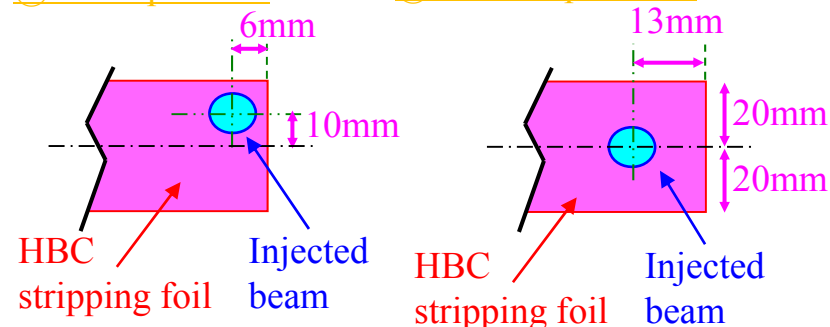

Large size & Ultra thin HBC Foils

- In order to measure the charge fraction of the HBC foils in the H^- beam energy of 181MeV, we installed large size and ultra thin HBC foils in this summer.

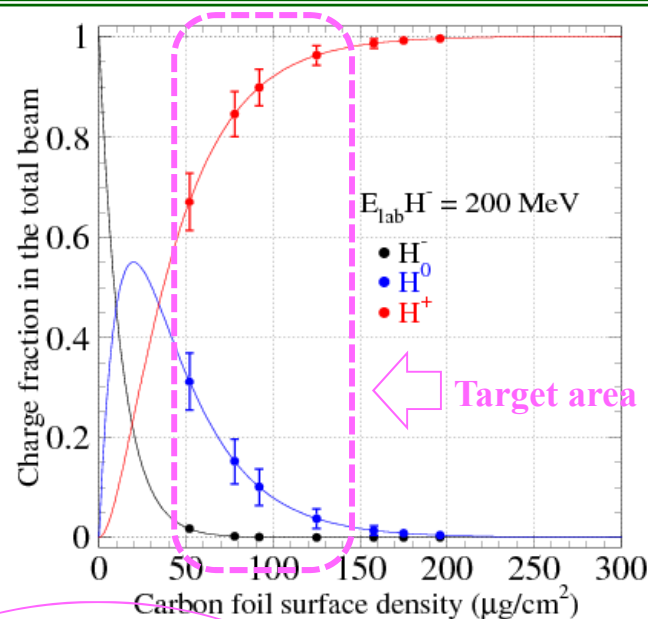

	Foil thickness [$\mu\text{g}/\text{cm}^2$]					
	(1)	(2)	(3)	(4)	(5)	(6)
New test foils	52	78	90	130	158	170

- Beam studies was carried out last month, but we used three foils because we had a short beam study time.

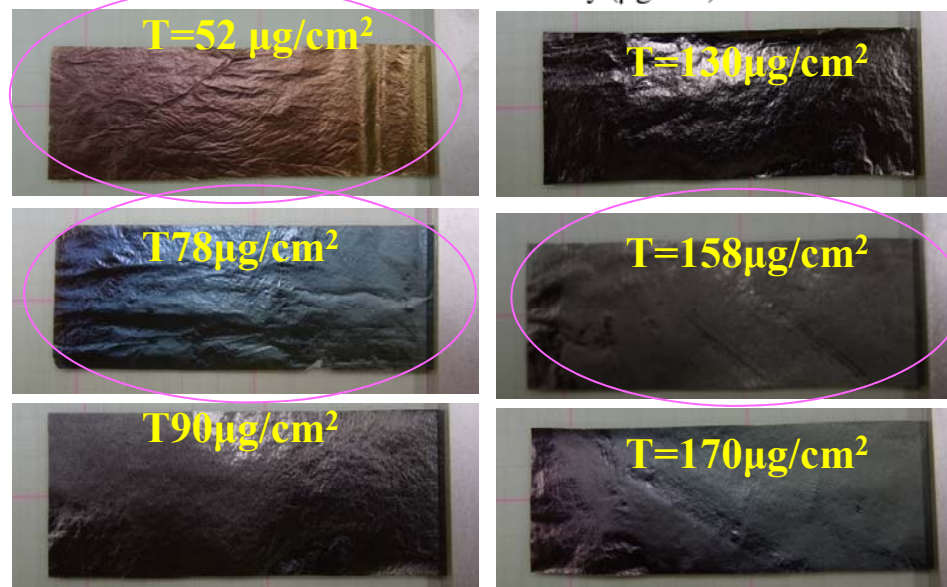

Recent foil studies (preliminary) [2]

- beam profile at H0-dump line with MWPM

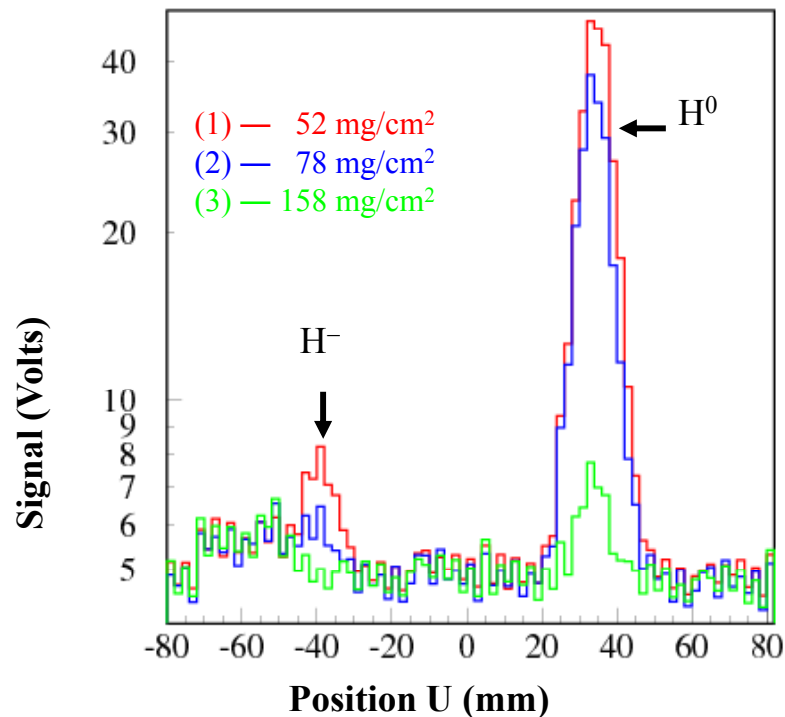

- Two beam orbits from H0 and H⁻ beam are separated at the entrance of H0-dump.
- Two beam profiles from H0 and H⁻ beam can be measured using the ultra-thin foils.

- Charge fraction measurement

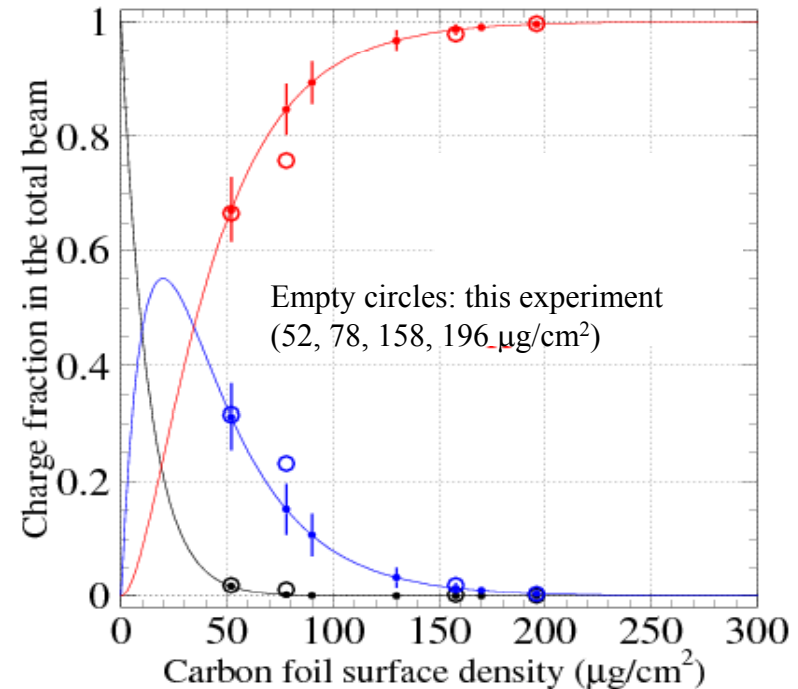

- Charge fractions of H0 and H⁻ can be measured by pulling out the 2nd and 3rd foil respectively.
- Except 78 μg/cm² target, all others look consistent!

- The beam studies with the HBC stripping foils were carried out in focusing on the beam scattering with HBC foils.
 - Beam survival dependence on the foil thickness was measured and the beam loss caused by the foils scattering was proportioned to the foil thickness.
- The beam irradiation to the user operation stripping foil with thickness of 196mg/cm^2 was started since RUN26 on October 2009.
 - Even after about 1.41×10^{21} particles irradiation, no noticeable deterioration of the stripping foils could be seen.
- The recent beam studies with large size and ultra thin HBC foils was started.
 - Charge fractions of H^0 and H^- can be measured by pulling out 2nd and 3rd foil respectively.