

# PRESENT STATUS AND FUTURE OF FFAGS AT KURRI AND THE FIRST ADSR EXPERIMENT

Y.Ishi, M.Inoue, Y.Kuriyama, Y.Mori, T.Uesugi, Kyoto University  
Research Reactor Institute, Osaka, Japan

JB.Lagrange, T.Planche, M.Takashima, E.Yamakawa, Graduate  
School of Engineering, Kyoto University, Kyoto, Japan

H.Imazu, K.Okabe, I.Sakai, Y.Takahoko,  
Fukui University, Fukui, Japan

# Contents

- Feature of ADSR
- ADSR studies in KURRI
- Design and Performance of FFAG Complex
- ADSR Experiments in KURRI
- Future plans of FFAG Complex
- Summary

# Contents

- Feature of ADSR
- ADSR studies in KURRI
- Design and Performance of FFAG Complex
- ADSR Experiments in KURRI
- Future plans of FFAG Complex
- Summary

# What is ADSR?

## Accelerator Driven Subcritical Reactor

ADSR is a system which keeps nuclear fission chain reaction induced by a large amount of spallation neutron obtained by irradiation of a heavy metal target using high energy proton beams generated by accelerators. In this system the nuclear reactor plays a role of neutron booster which amplifies the neutron flux from the target.

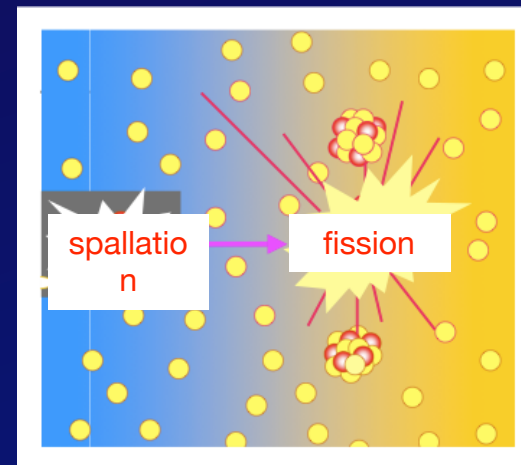
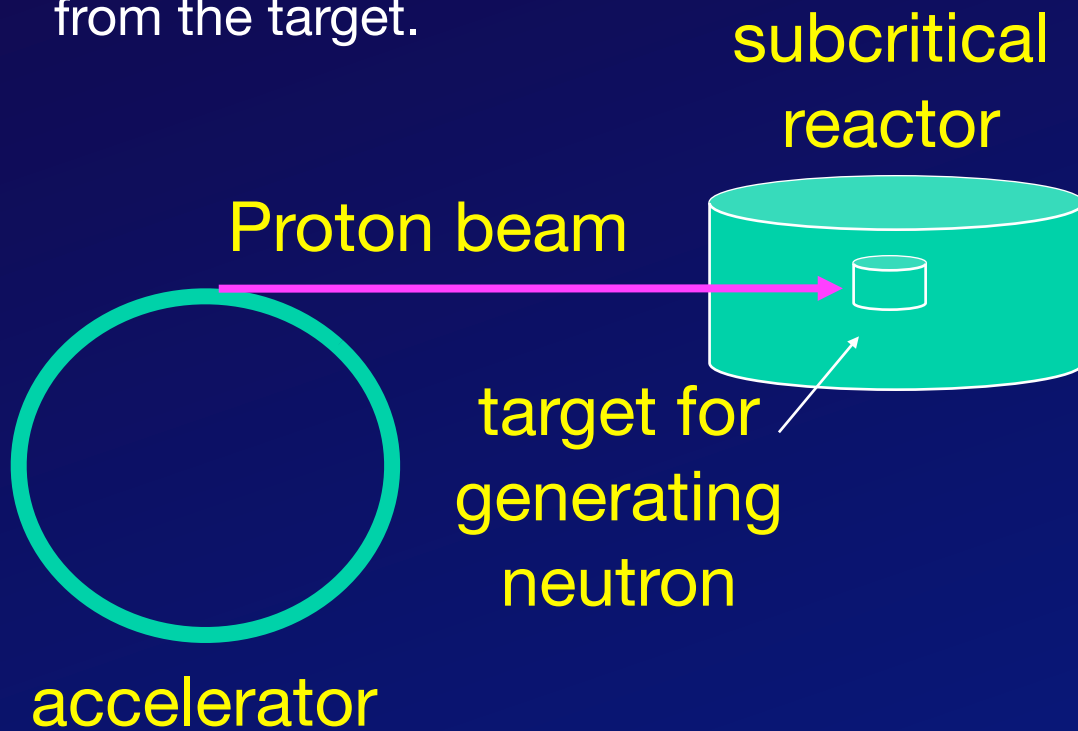

Beam off → chain reaction stops  
Safer system !

# Feature of ADSR

The output of the nuclear reactor can be controlled by changing the beam power from the accelerator. Output from the sub-critical reactor is expressed as

$$P \sim \frac{S}{1 - k_{eff}}$$

$k_{eff}$  : effective multiplication factor of subcritical fuel system controlled by rods

$S$  : neutron intensity controlled by energy and/or intensity of the beam from the accelerators dynamically

	beam current	high energy	variable energy
Synch	× space charge	○	○
Cycl	○	△	△
FFAG	○ high rep.	○ large $k \rightarrow$ compact	○ trim coils

Fixed Field Alternating Gradient (FFAG) synchrotron which realizes high beam current and high beam energy (variable) simultaneously has been adopted as the accelerator which drives ADSR.

# Contents

- Feature of ADSR
- **ADSR studies in KURRI**
- Design and Performance of FFAG Complex
- ADSR Experiments in KURRI
- Future plans of FFAG Complex
- Summary

# ADSR Studies in KURRI

## Purpose

- The main purpose of this R&D is a basic feasibility evaluation of ADSR as an energy production device.
- It is also required to compare the nuclear design calculations with the experimental data concerning sub-critical reactor characteristics mainly on the neutron multiplication which depends on the energy of the neutrons.

An aerial photograph of the Kyoto University campus. The image shows a mix of green fields, trees, and urban buildings. A river flows through the middle of the campus. Two specific reactor locations are highlighted with blue text boxes: KUR (5MW) in the upper-middle section and KUCA (10W) in the lower-middle section. The KUR reactor is a large, circular, white structure. The KUCA reactor is a smaller, more complex structure with several buildings and a central tower.

**KUR(5MW)**

KUCA (Kyoto University Critical Assembly) is used as the sub-critical reactor for this experiment.

The maximum output 100W (1kW for short term operation, 10W or less for usual), it is easy to rearrange the reactor core.

**KUCA (10W)**

# KUCA

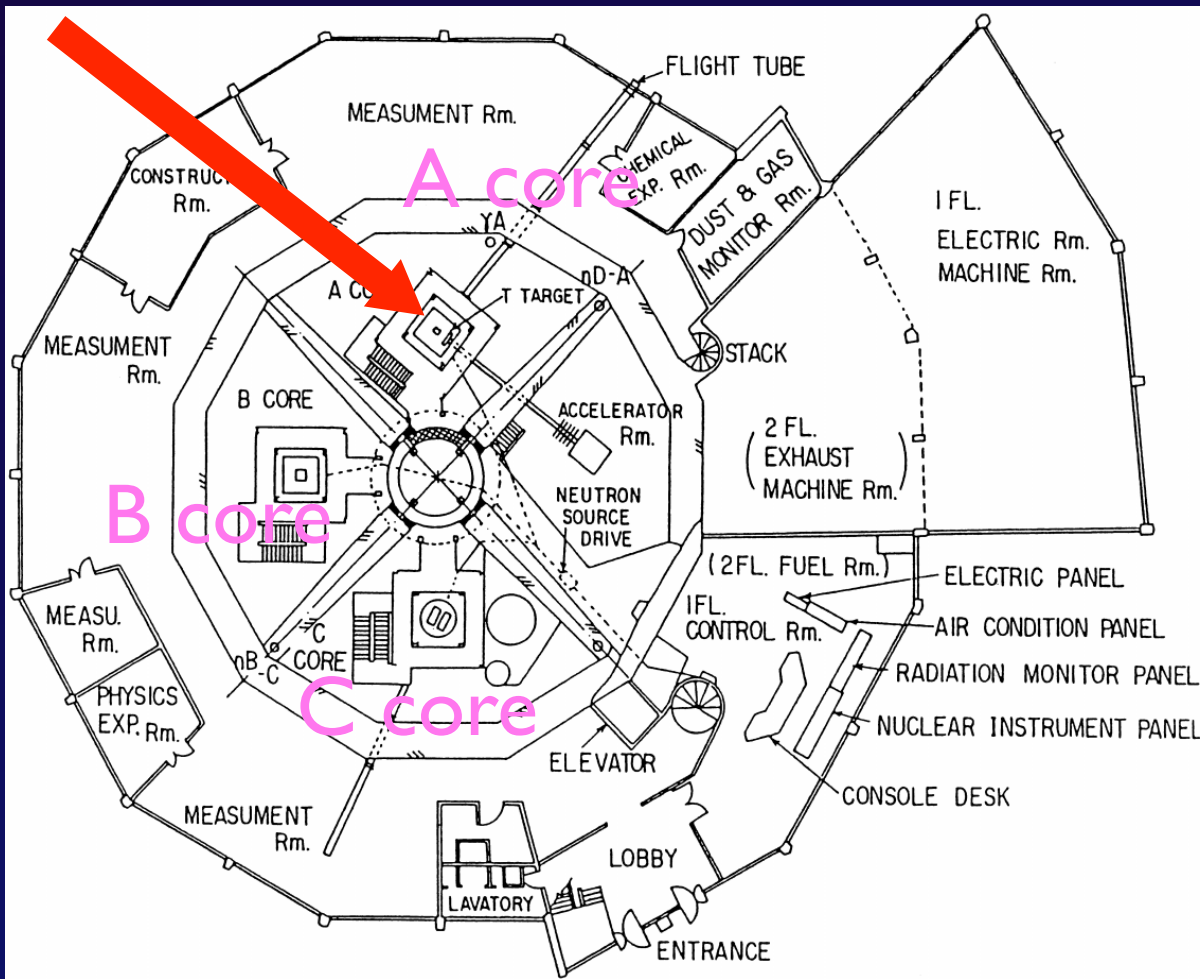

## ◆ KUCA Configurations

- 3 critical assemblies :
  - i. A & B cores  
Polyethylene Mod./  
Ref.
  - ii. C core  
H<sub>2</sub>O Mod./Ref.
- 2 accelerator :
  - i. Cockcroft-walton type  
(D,T) reaction  
14 MeV neutrons
  - ii. FFAG type  
100 MeV protons  
from KUCA Outside

Output power ~10W

Neutron multiplication :  $\alpha=1/(1-k_{eff})$ .

If  $k_{eff}=0.99$ ,  $\alpha=100$

Beam power requirement not exceed  $< 0.1W!!$

cf. For 100MeV proton beam,  $I < 1nA$

# FFAG – KUCA ADSR system schematic diagram

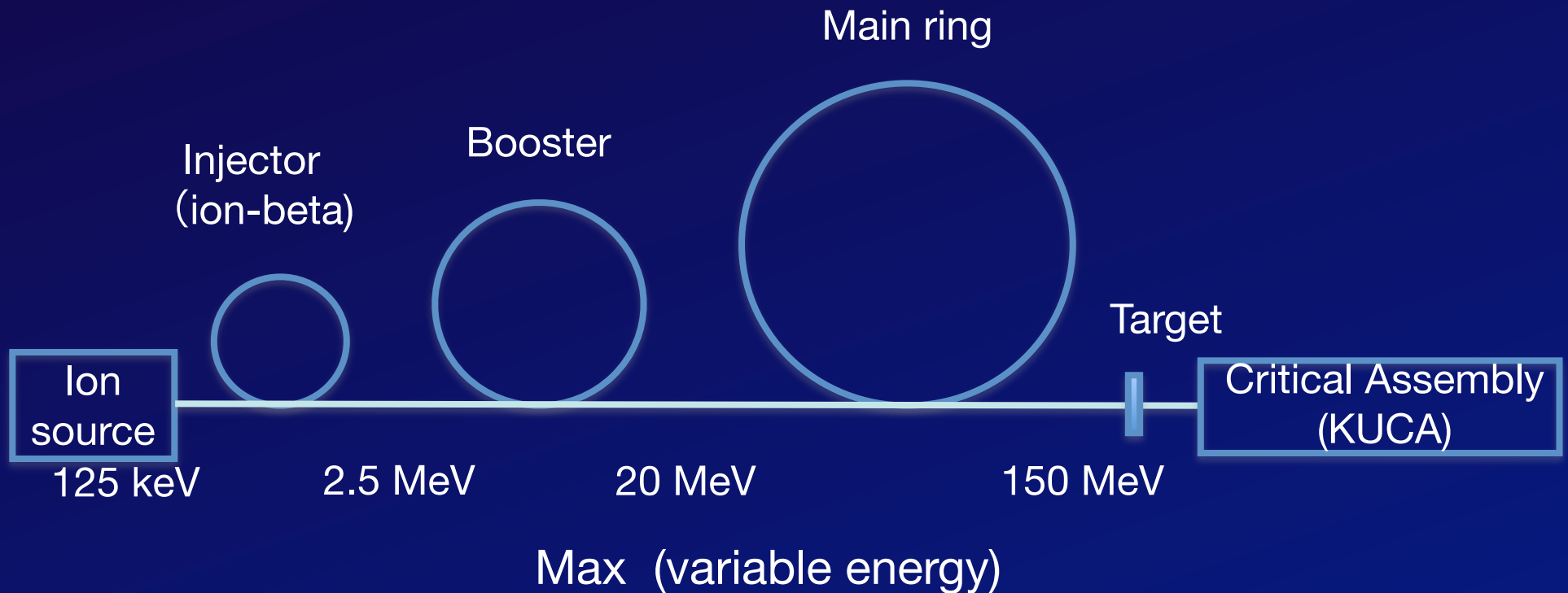



Innovation research lab.

The KURRI-FFAG accelerator complex has been constructed in the innovation research lab. ; connected to KUCA to deliver the high energy proton beam.

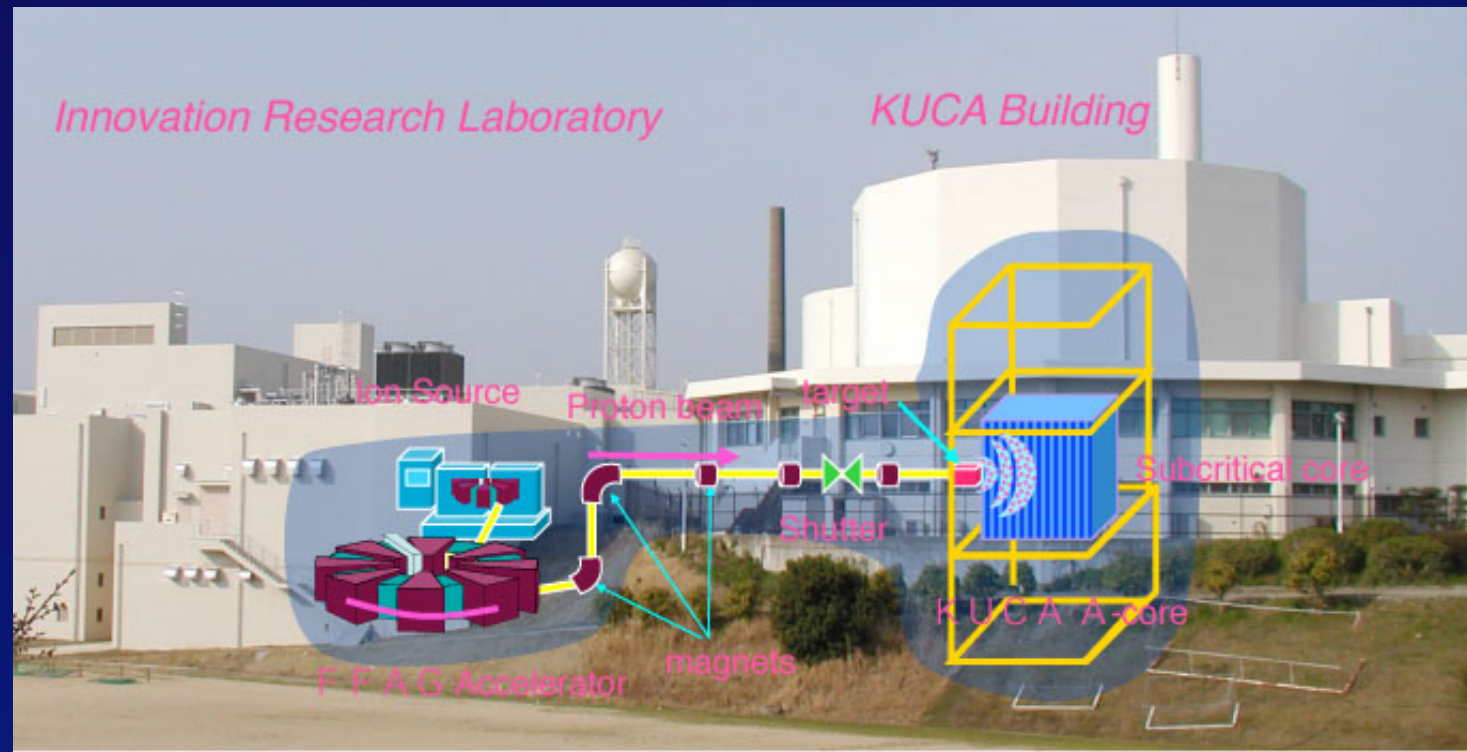

# Basic parameters for ADSR experiments at KURRI

- Reactor output power  $\sim 10\text{W}$
- Neutron multiplication  $< 100(\text{max.})$
- Beam power of FFAG  $< 0.1\text{W}$
- Beam energy of FFAG  $100\text{-}150\text{MeV}$
- Beam current of FFAG  $< 1\text{nA}$

# Contents

- Feature of ADSR
- ADSR studies in KURRI
- **Design and Performance of FFAG Complex**
- ADSR Experiments in KURRI
- Future plans of FFAG Complex
- Summary

# KURRI-FFAG complex

KUCA

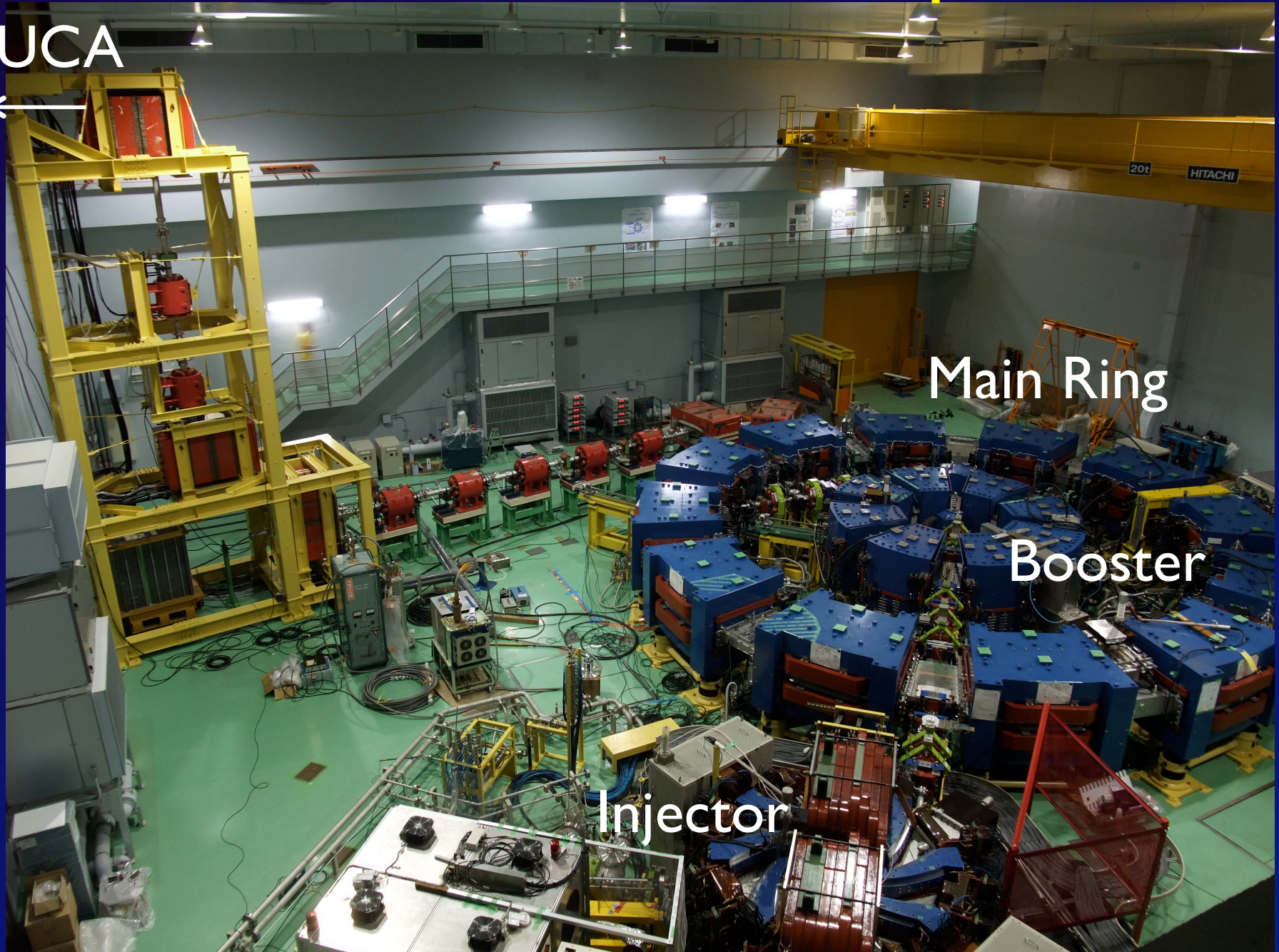
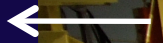

Main Ring

Booster

Injector

# Parameters of FFAG complex

	Injector	Booster	Main Ring
Lattice	Spiral, 8 cells	Radial, 8 cells	Radial, 12 cells
Acceleration	Induction	RF	RF
Field index, $k$	2.5*	2.5	7.5
Energy (max)	1.5MeV (2.5 MeV*)	11MeV (20 MeV)	100MeV (150 MeV)
$P_{ext}/P_{inj}$	5.00(Max)	2.84	2.83
Average orbit radii	0.60 - 0.99 m	1.42 - 1.71 m	4.54 - 5.12 m

\* Output energy of the injector is variable

# The Injector (Ion beta)

World's first trials in proton FFAG:

- Spiral sector magnet
- Induction acceleration
- Variable energy by using multi-pole face winding coils

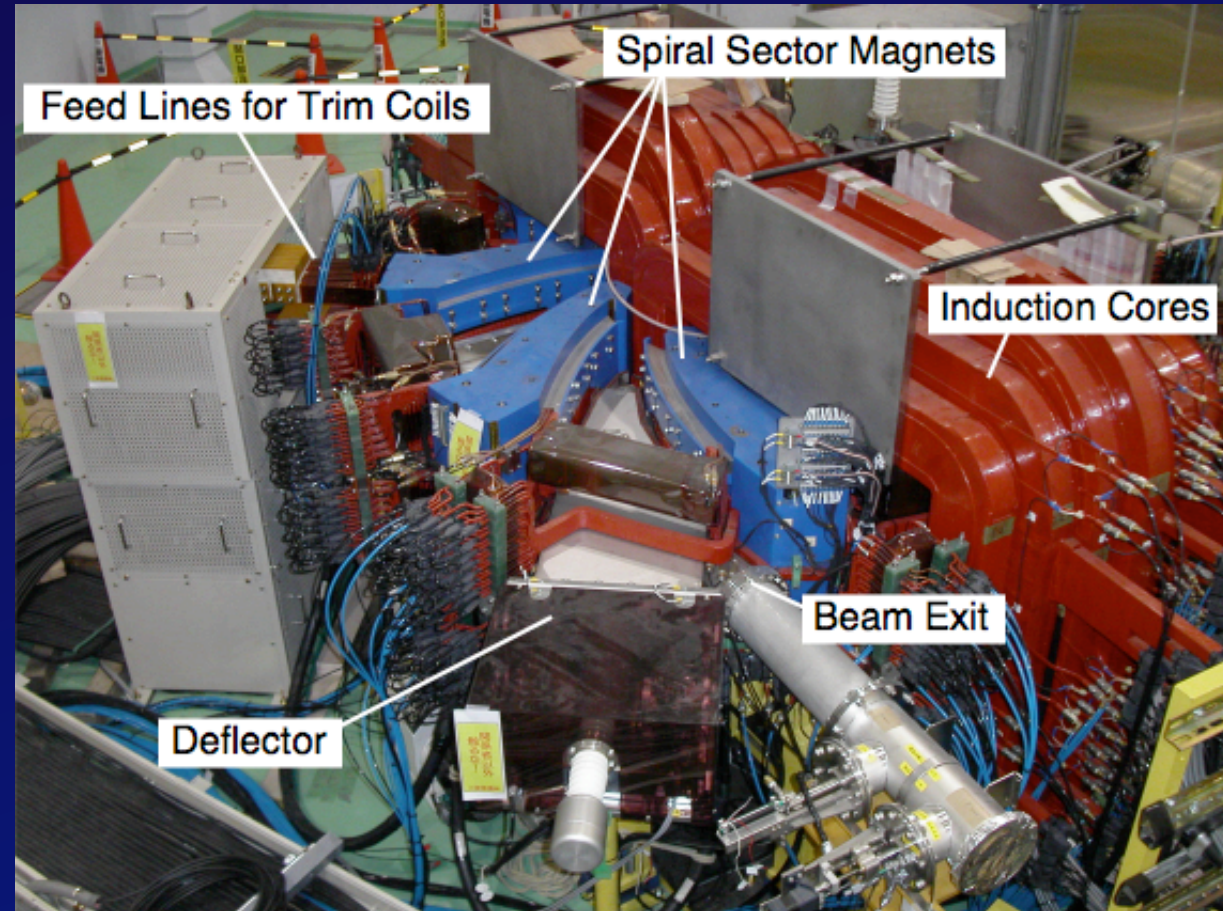

Independent 32 pole face winding coils



beam chopper

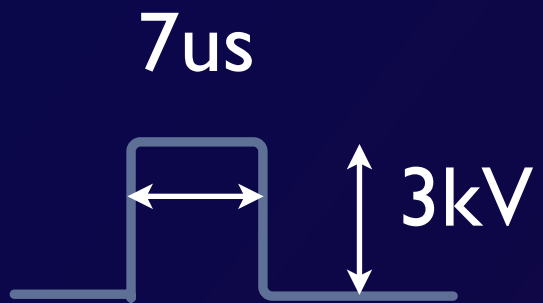
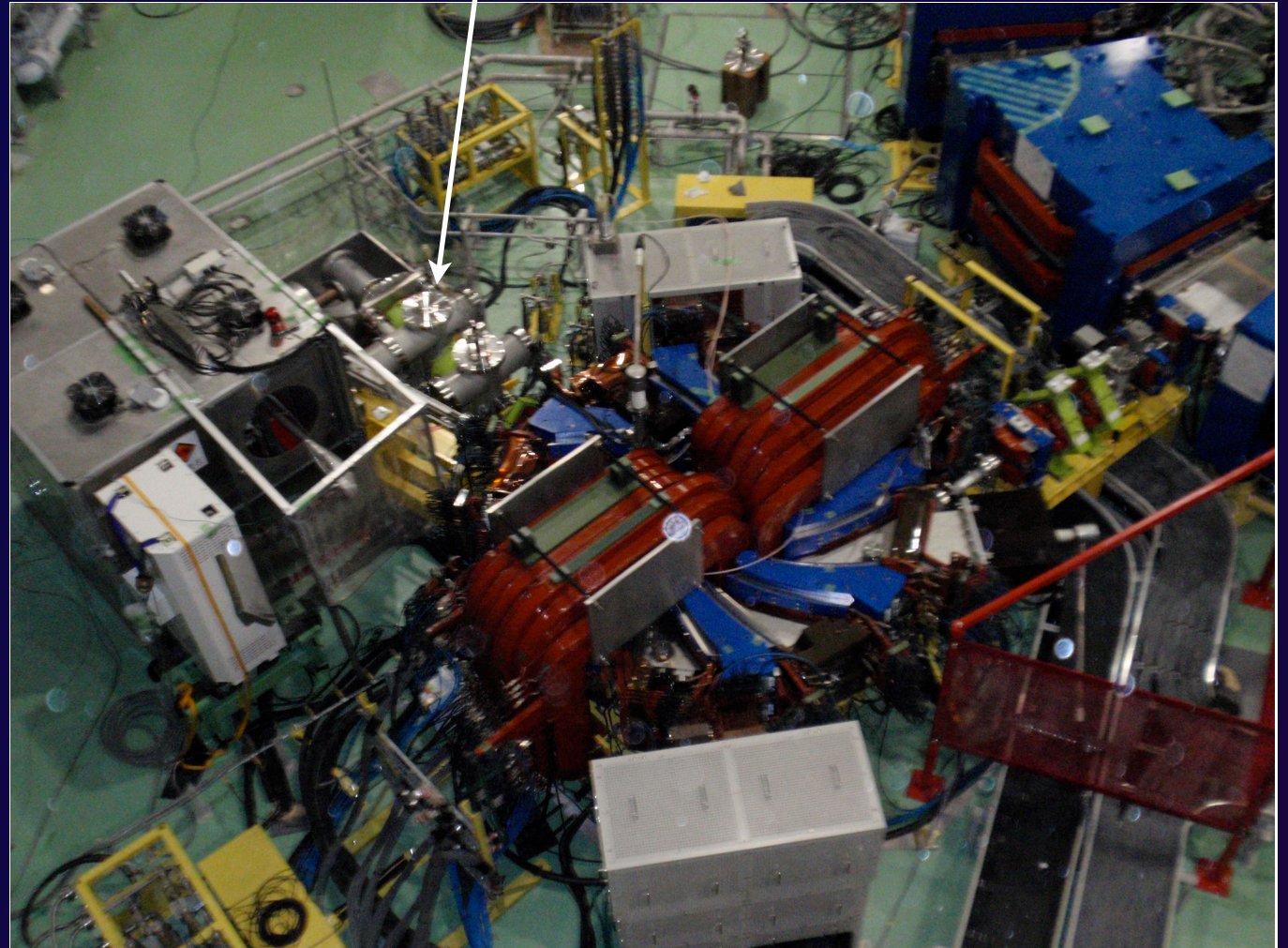

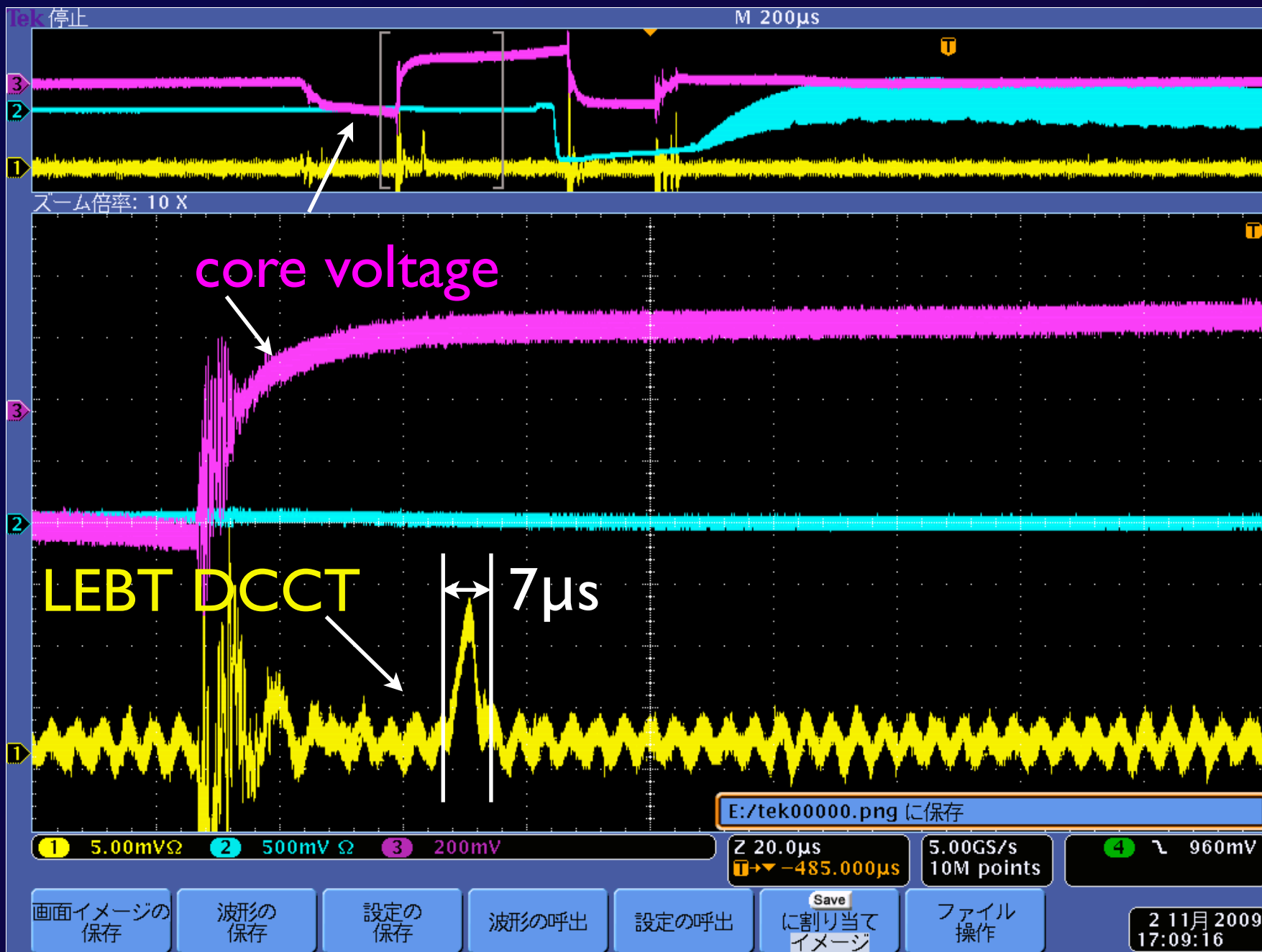

# operating point of the injector

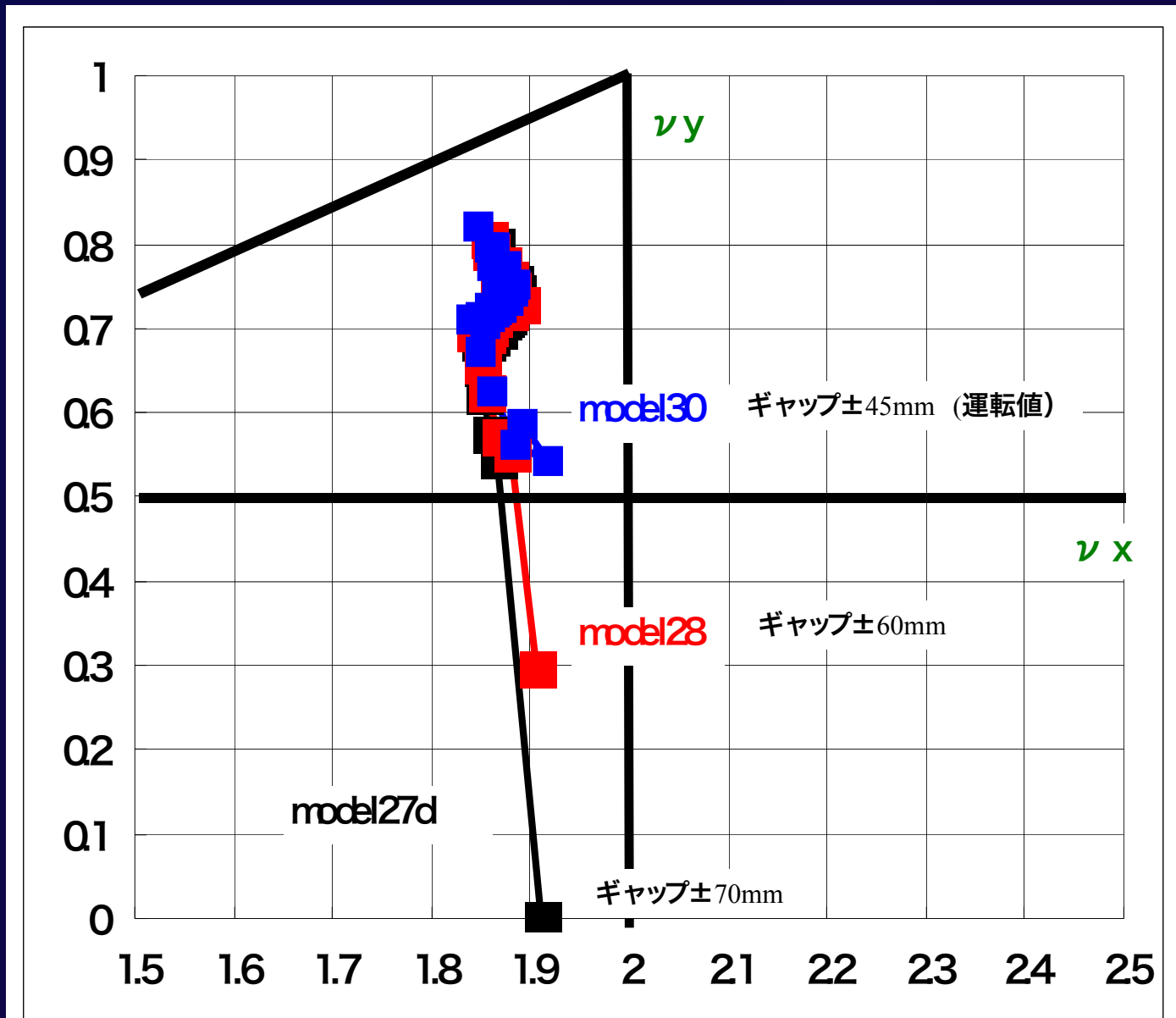

# Configuration of induction cores

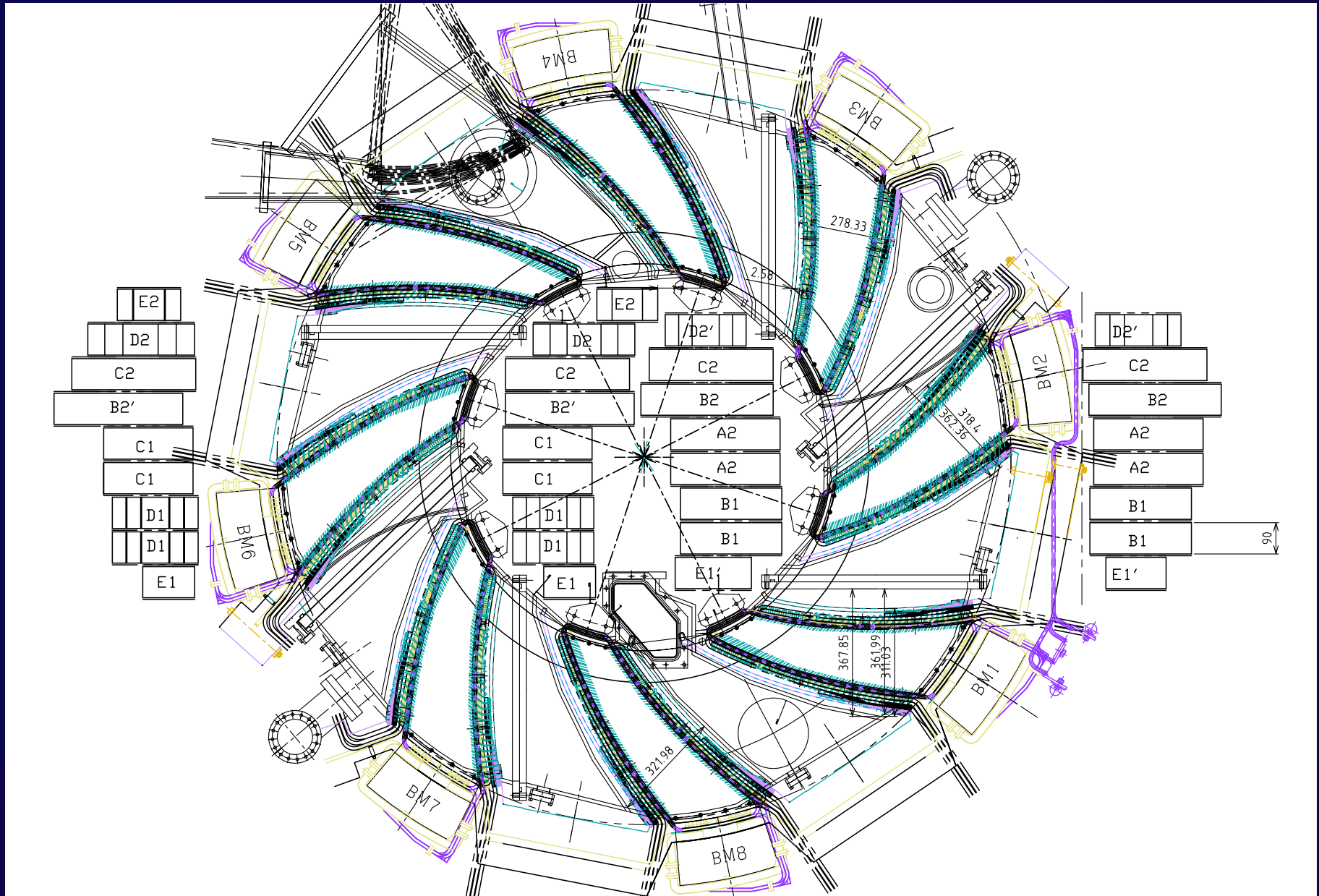

# Production of induction core

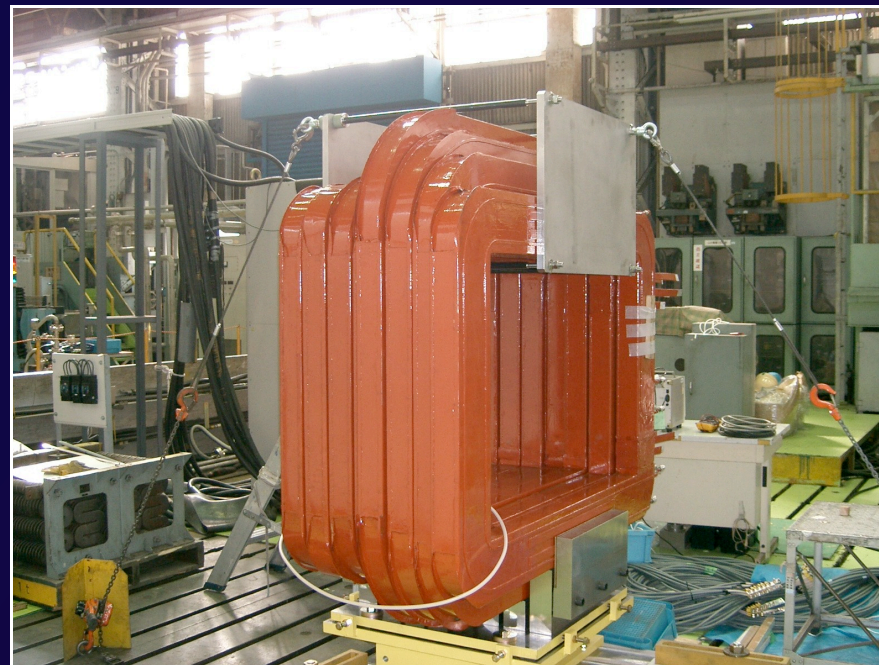

# Capability of variable energy

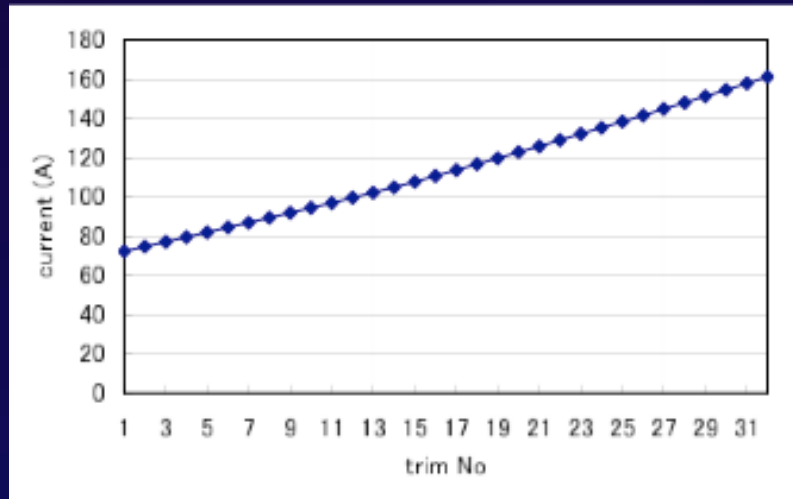

Pattern I

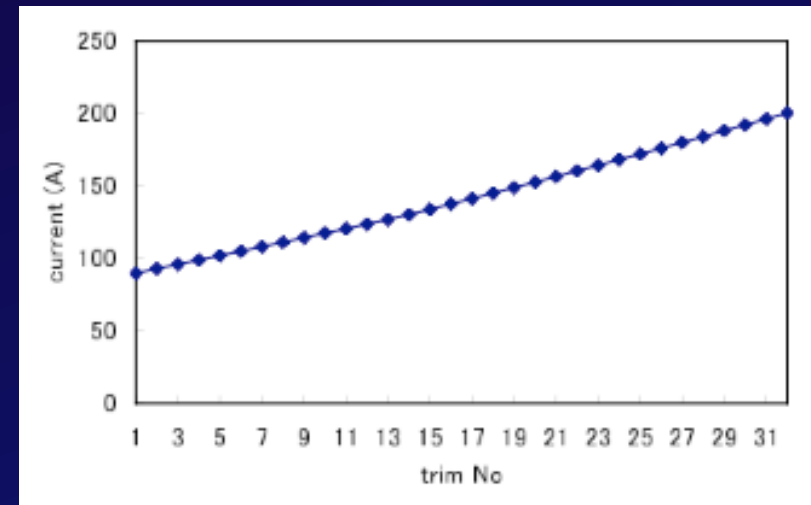

Pattern II

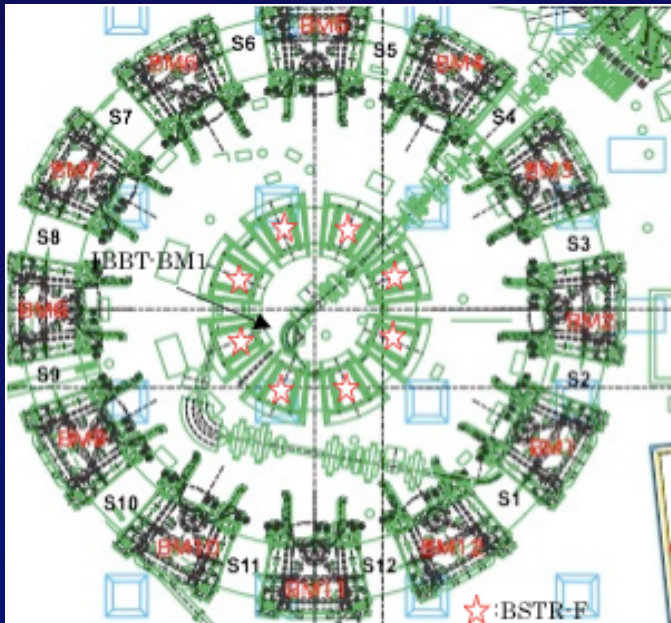

	Pattern I	Pattern II	Momentum ratio (II/I)	Energy ratio (II/I)
Capture Freq. in the Booster (kHz)	1725.1	1962.0	1.142	1.282
BSTR-F (A)	112.9	128.8	1.141	1.279
IBBT-BMI (A)	380.9	438.9	1.152	1.302

30% of energy variation has been tested with different pattern of trim coil excitation

# Booster

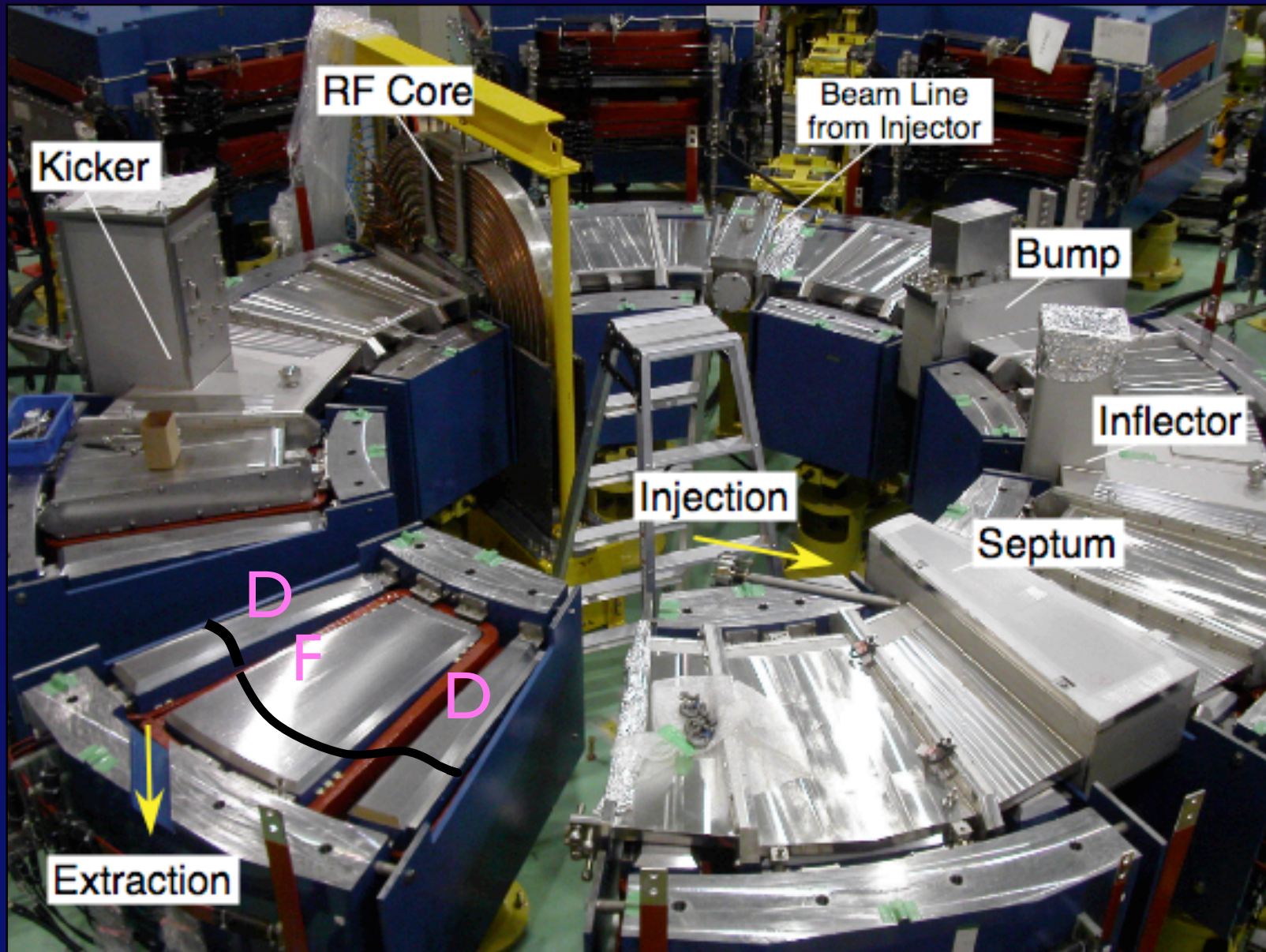

# ブースター機器配置図

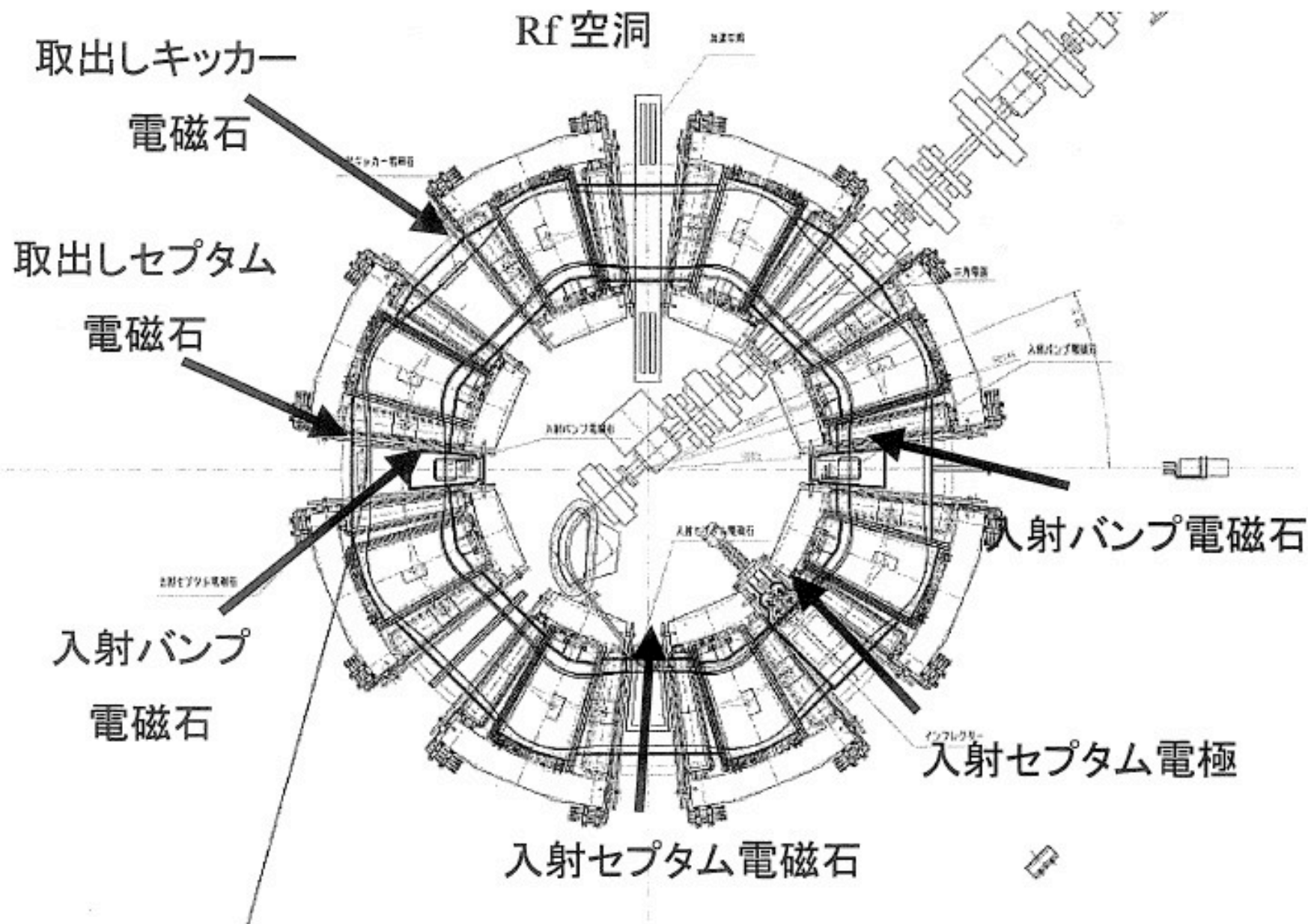

# Lattice functions of the Booster

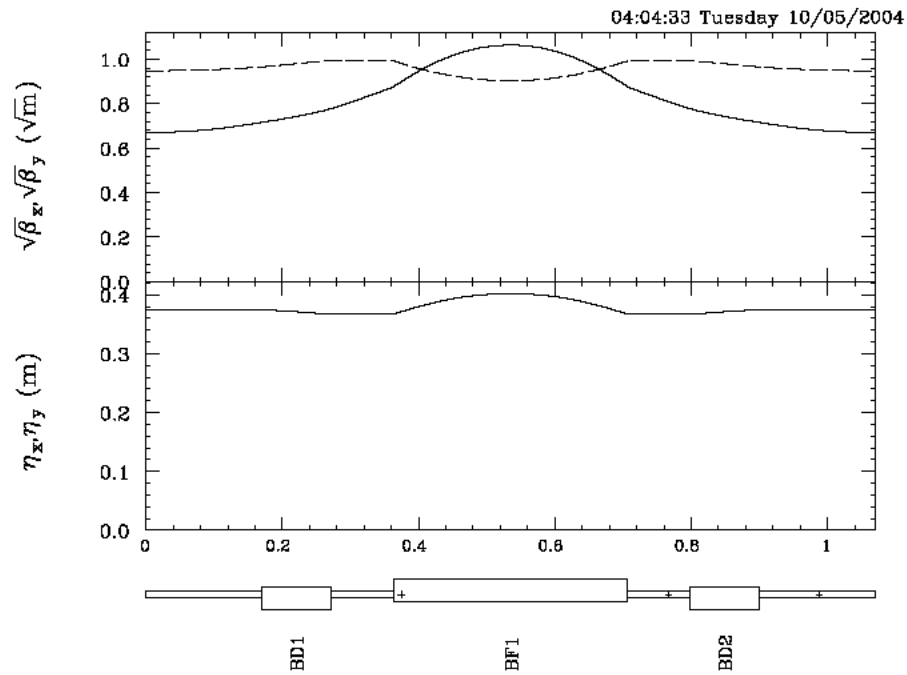

at the injection

at the extraction

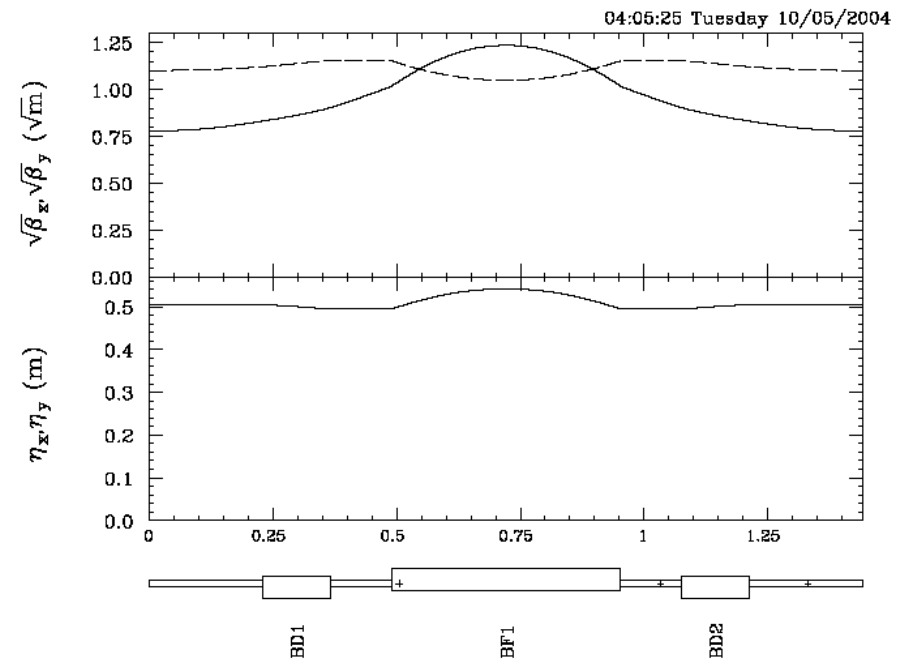

# Magnet shape of the Booster

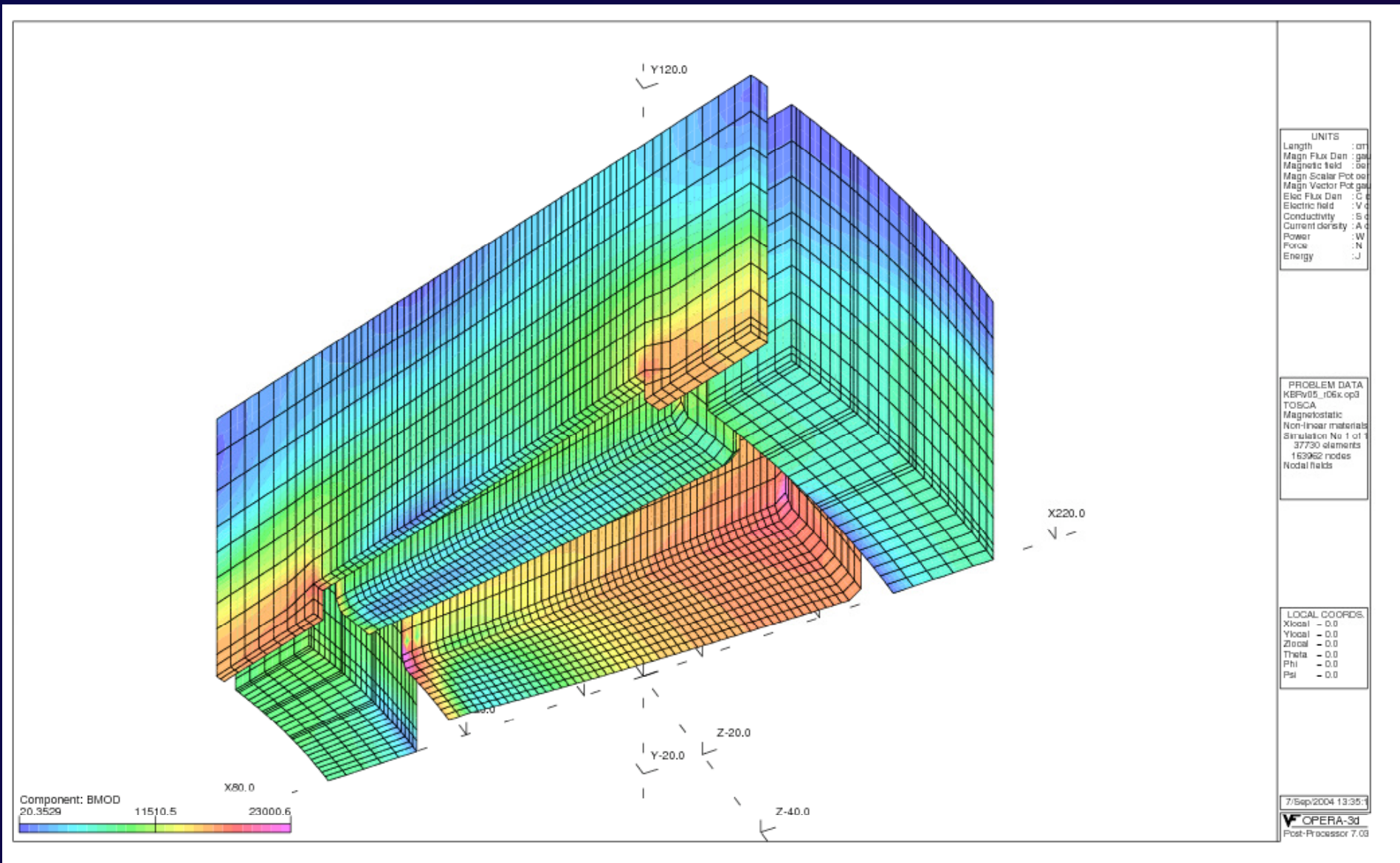

# $B(r), k(r)$

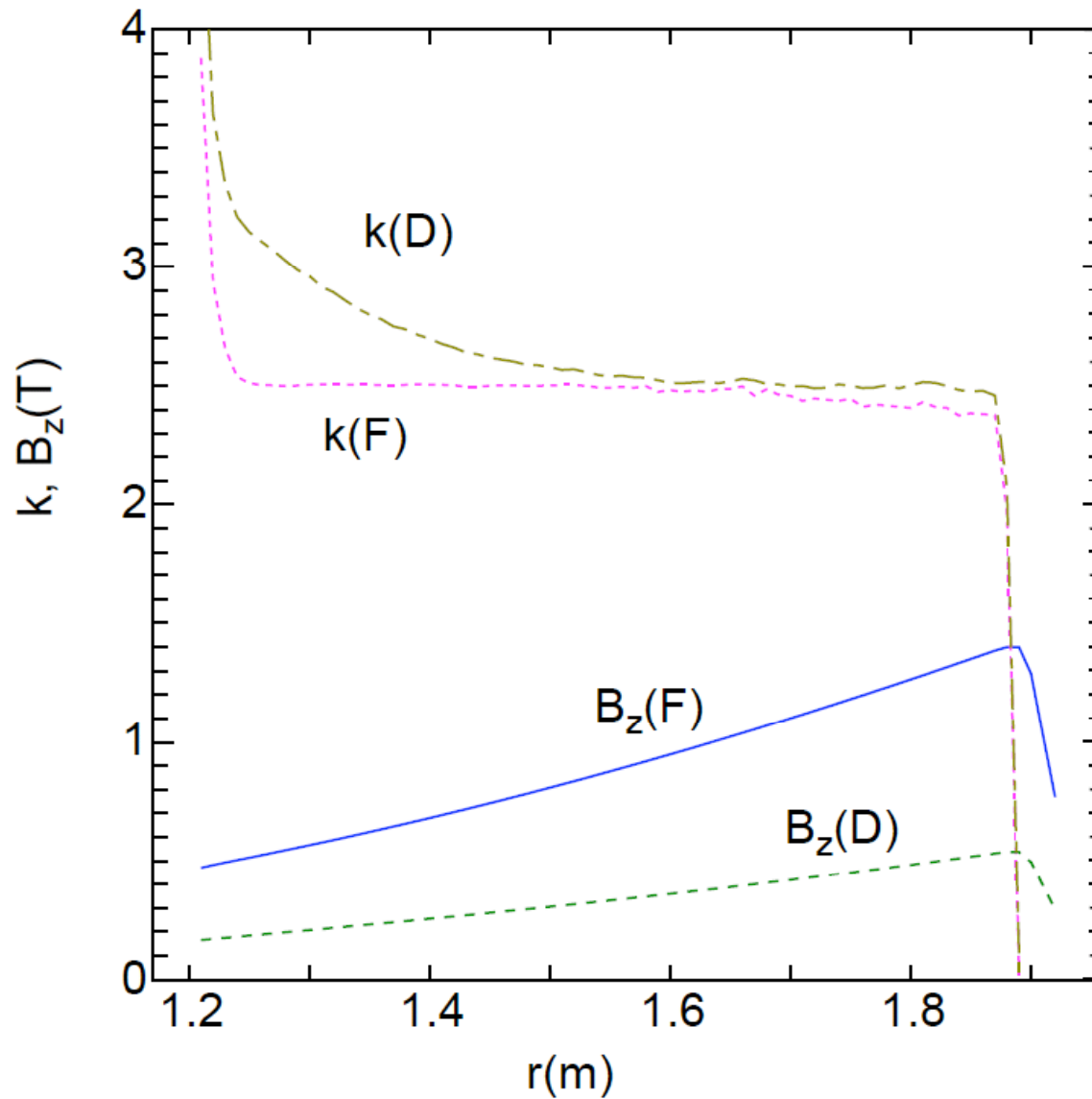

# $B(\theta)$

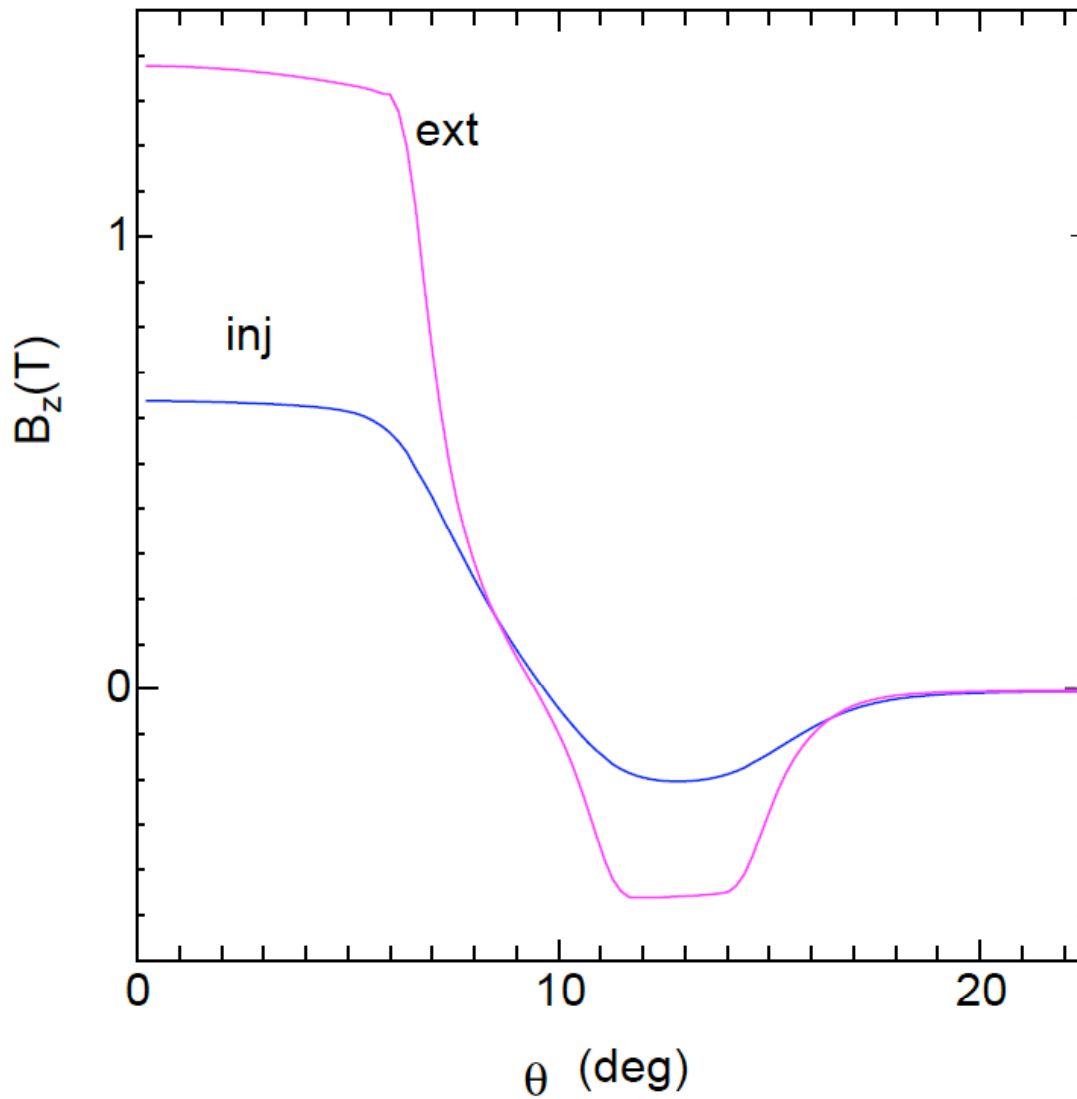

# Tune variation in the Booster

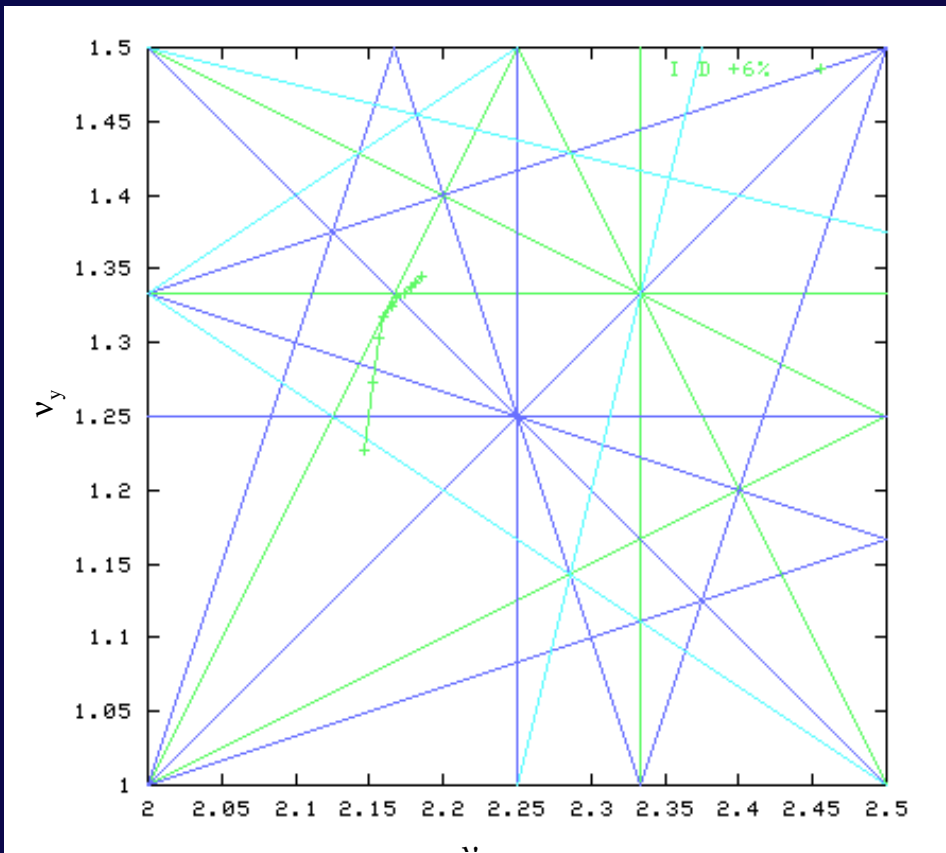

tracking

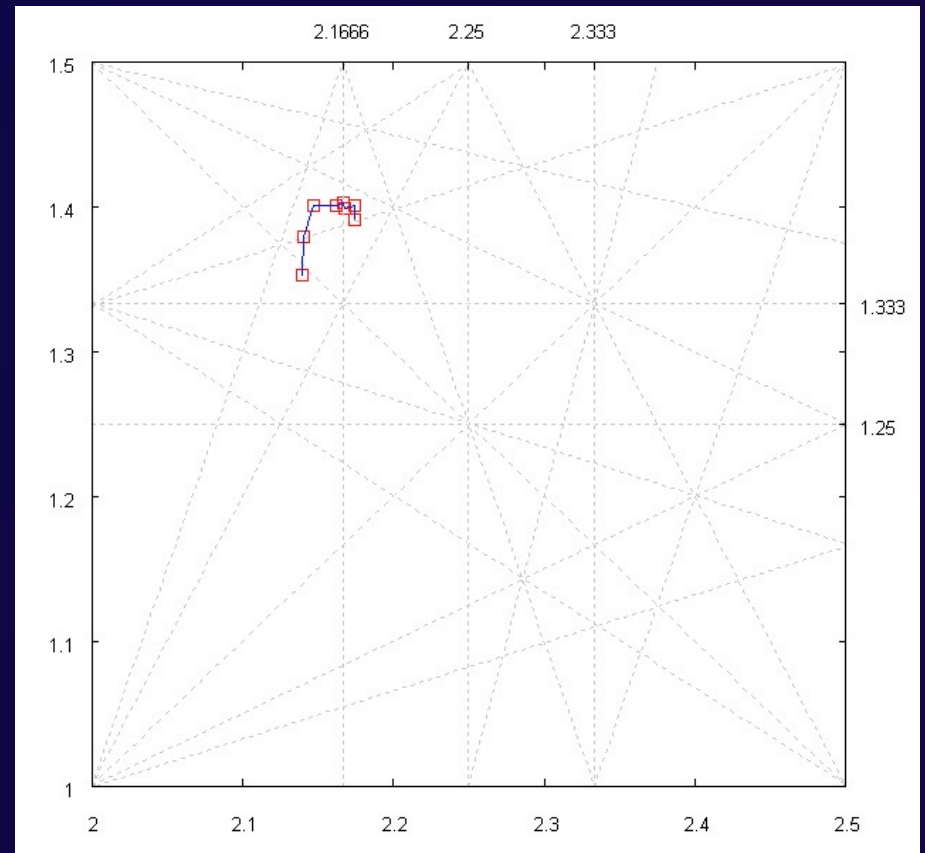

measurement

# Beam injection to the booster

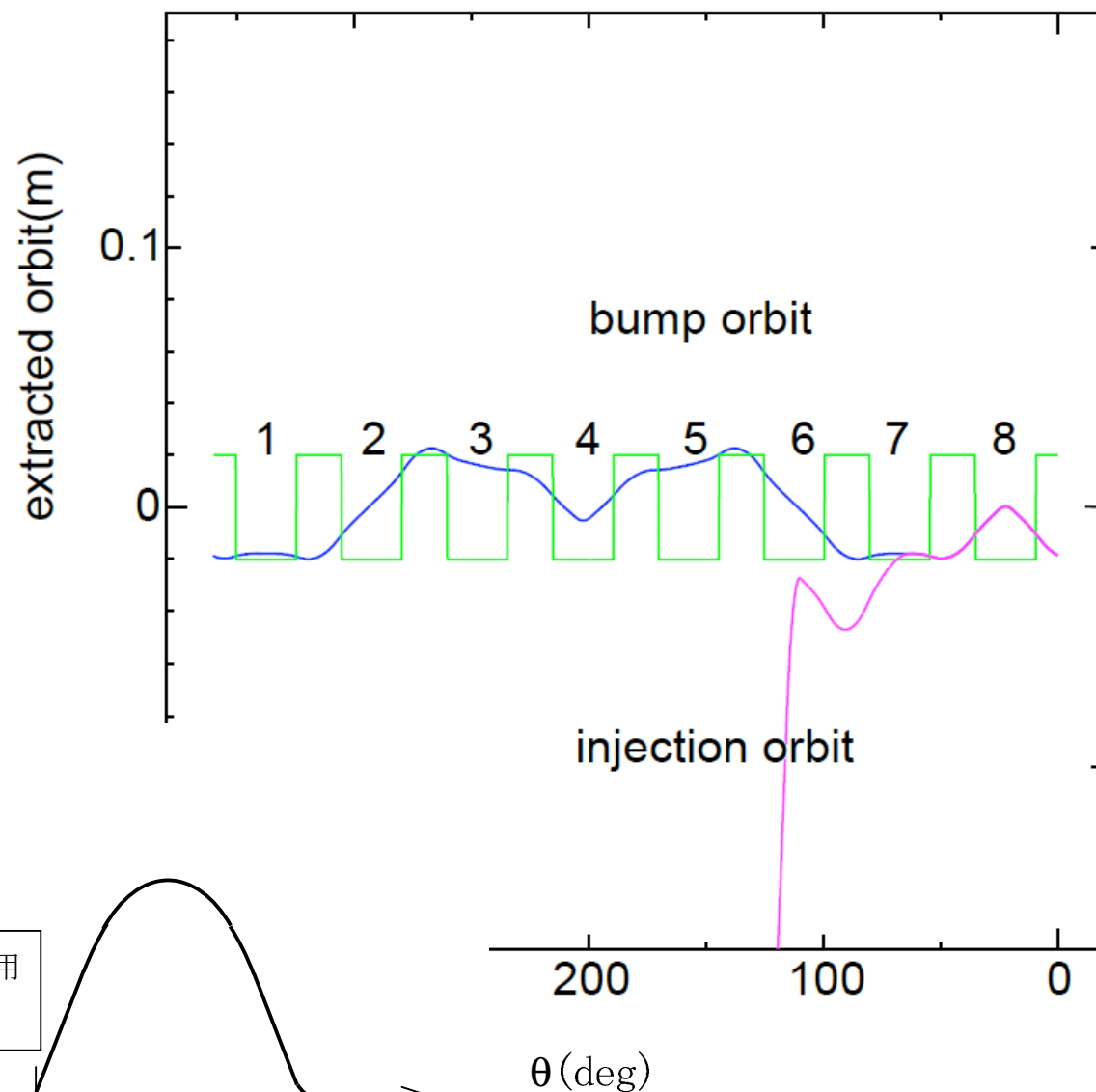
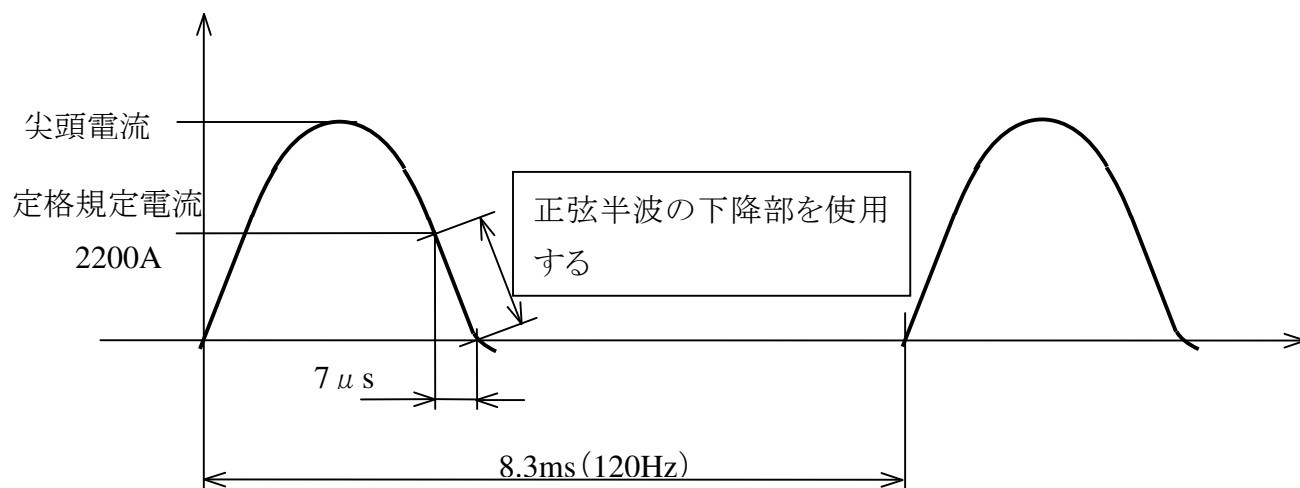

# Bunch monitor signal at the injection

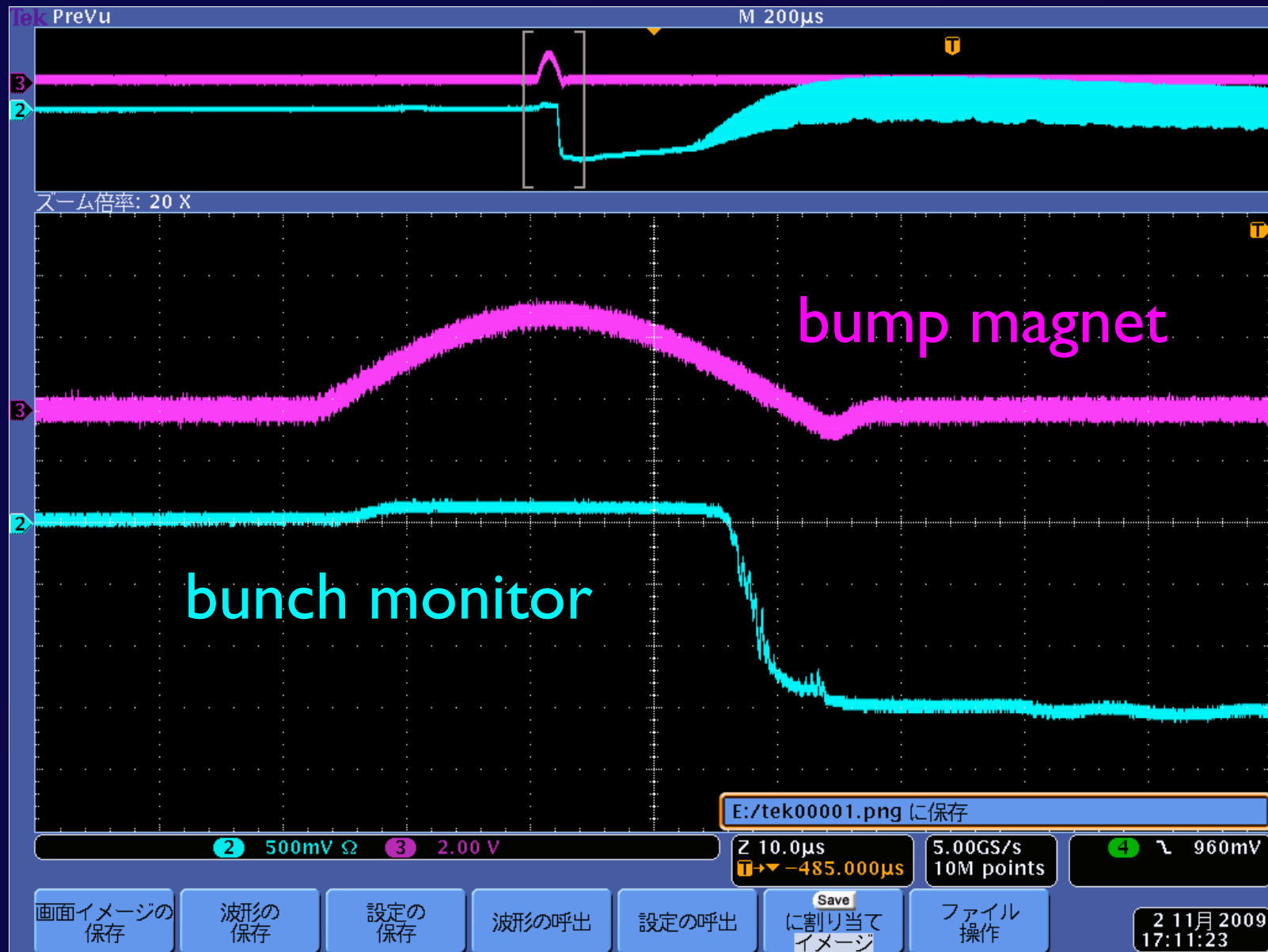

# extraction orbit

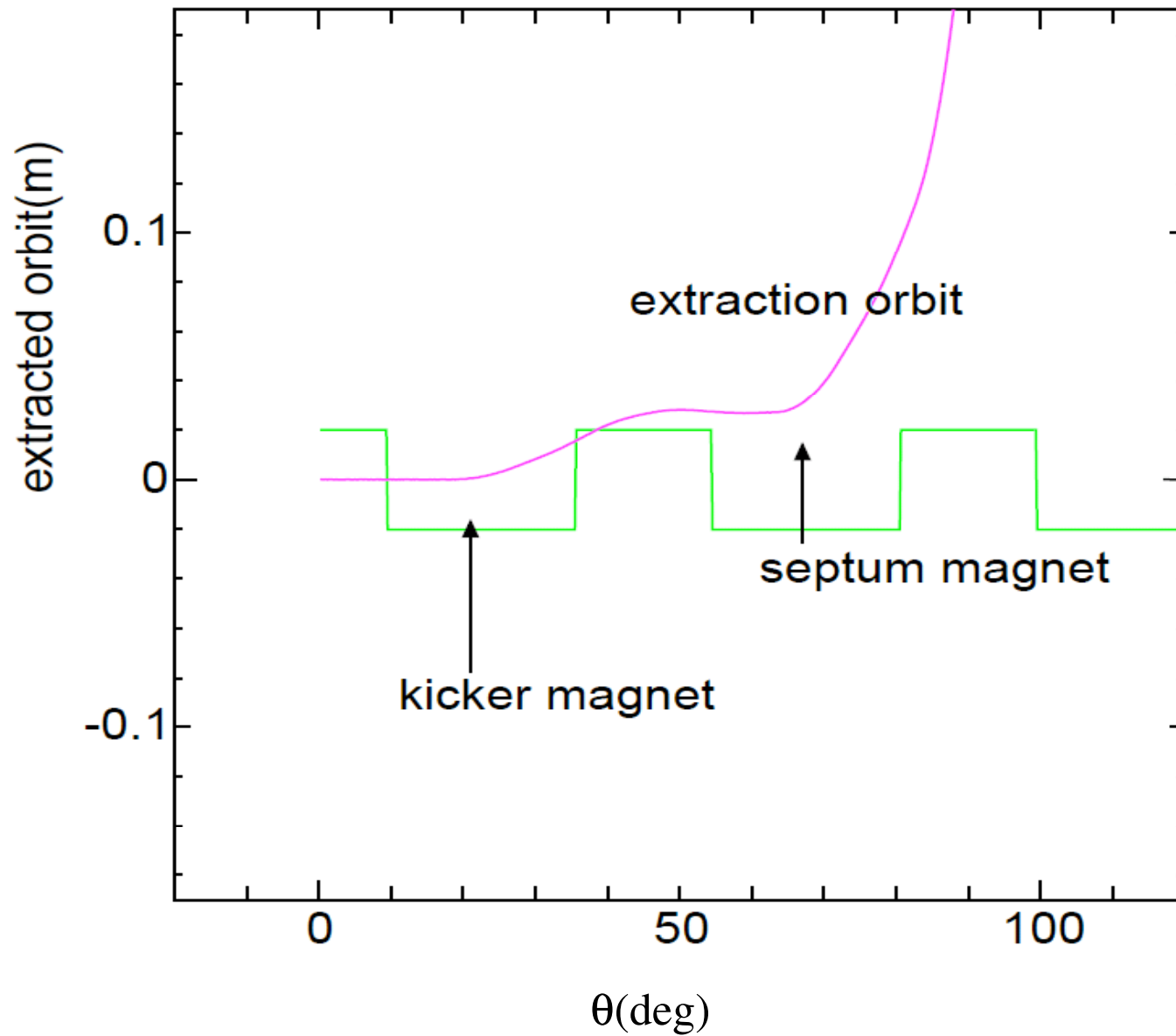

# booster bunch monitor signal

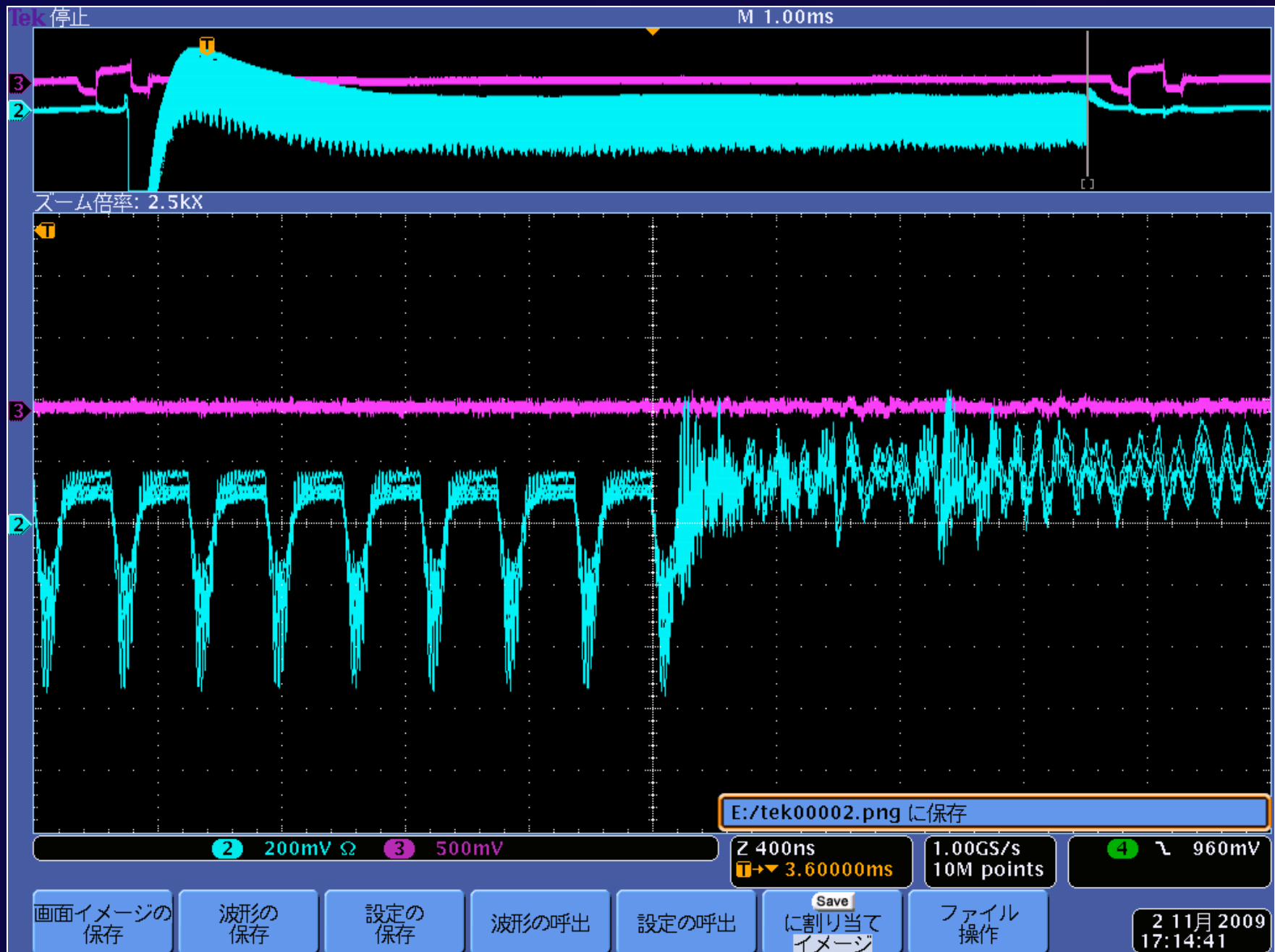

# Main Ring

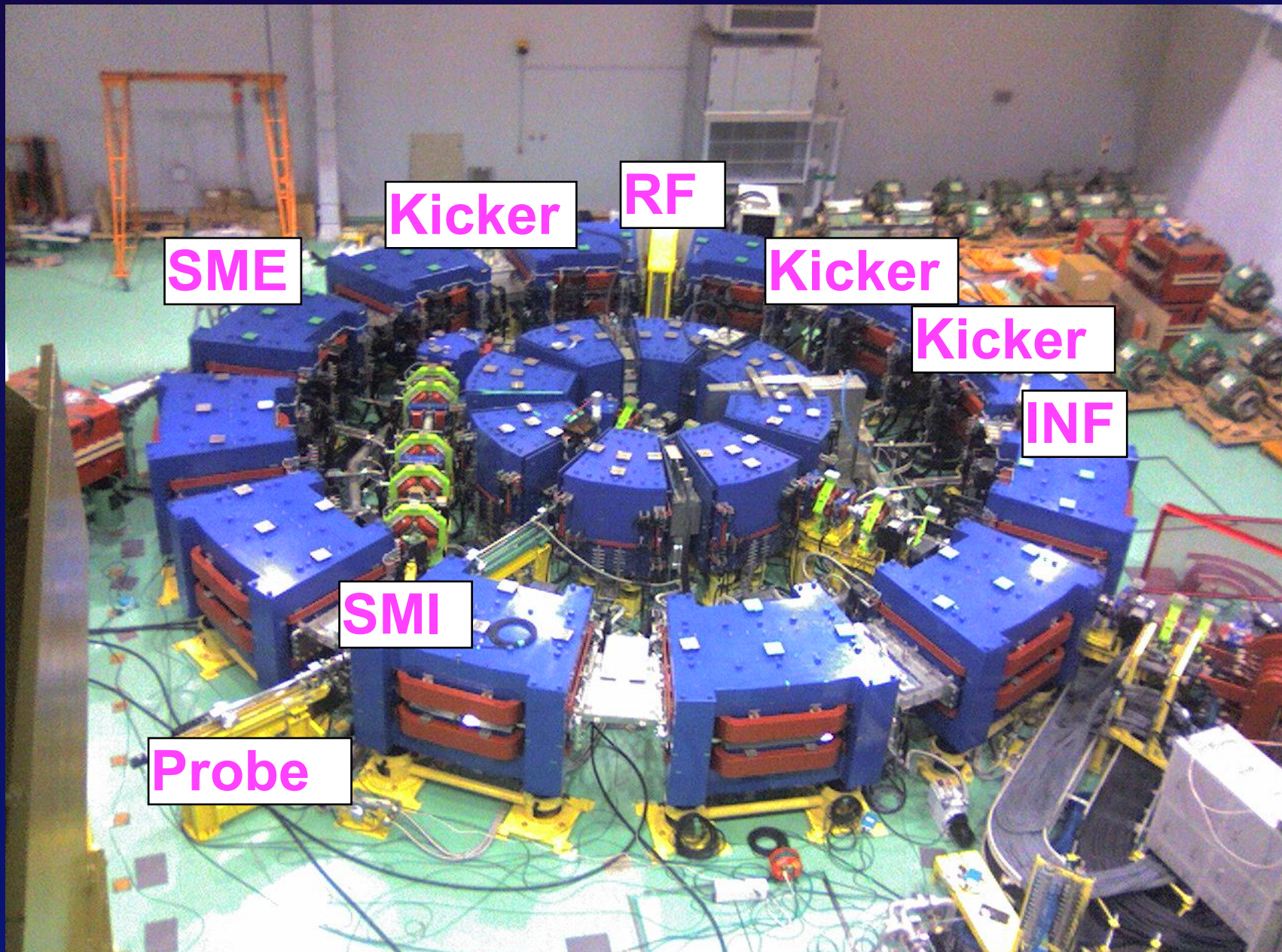

# Injection Orbit

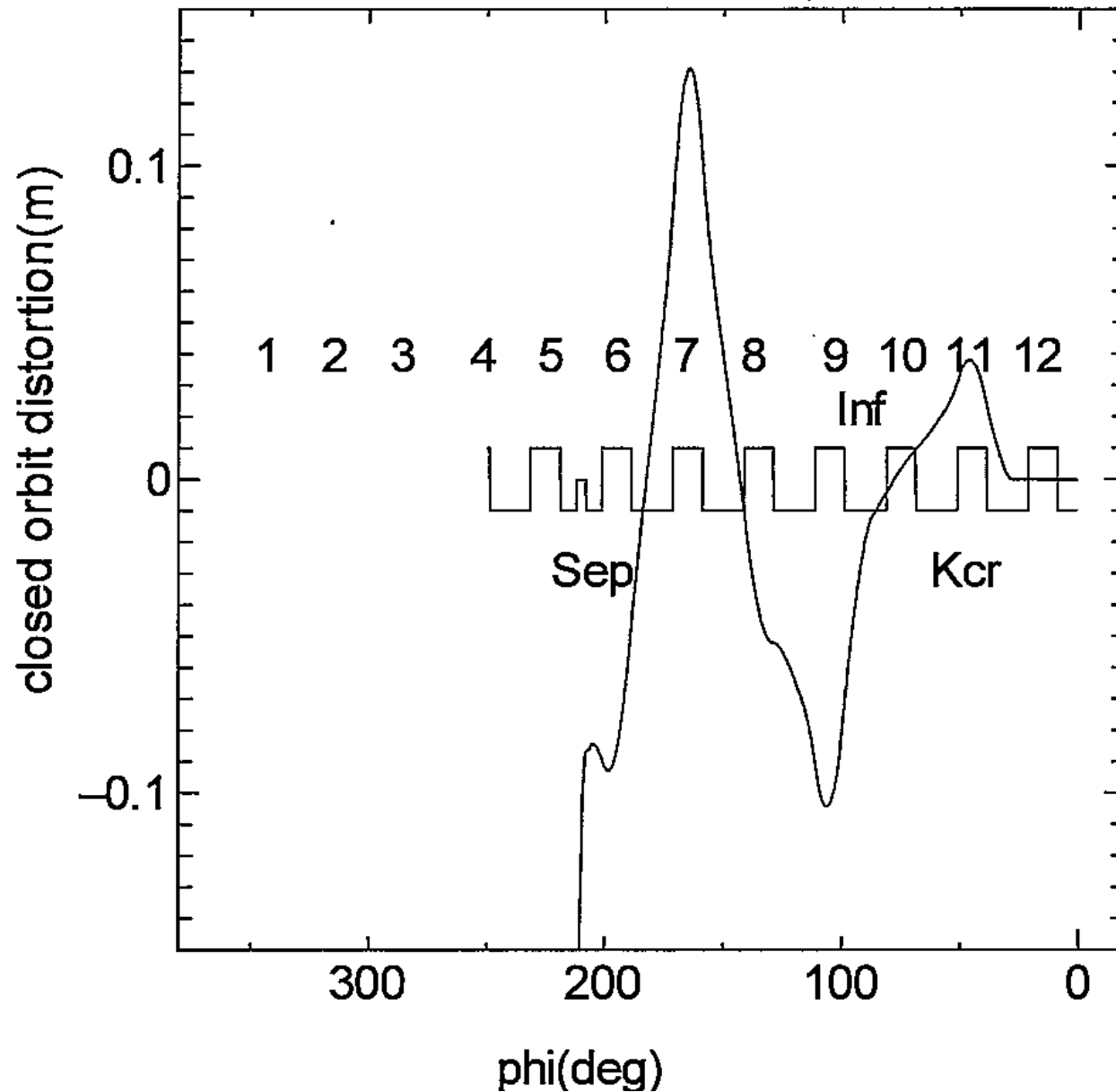

# Turn separation at the inflector and the septum magnet

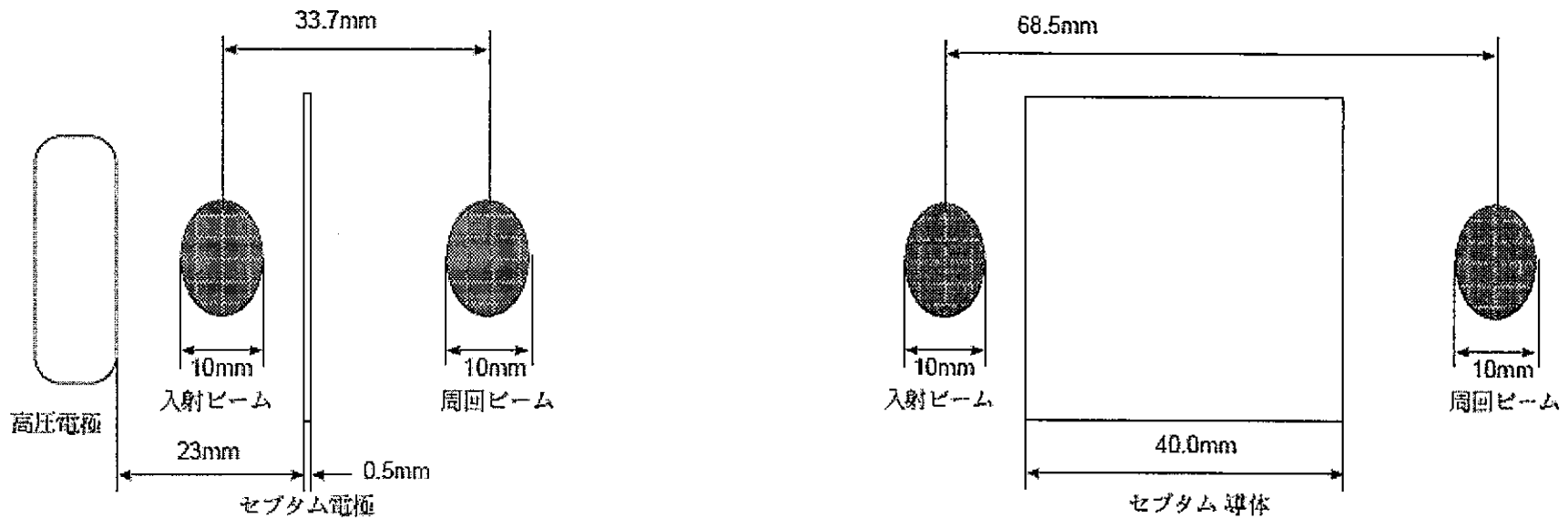

# BMBT



injection septum  
magnet

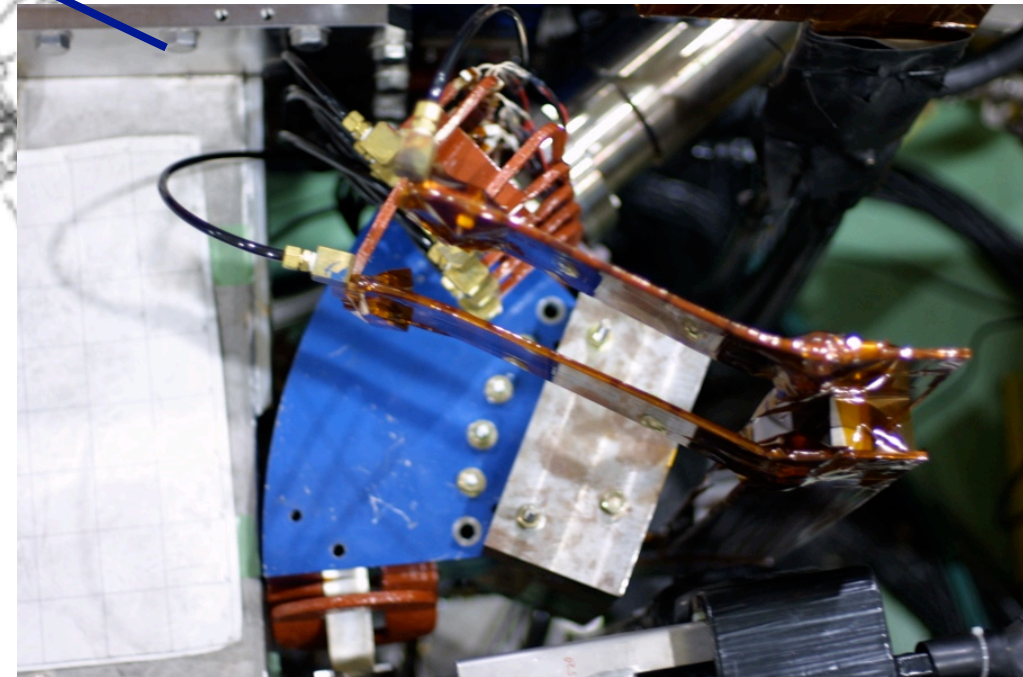

# Do not use magnetic stuff even for a base

Test\_07-12-18

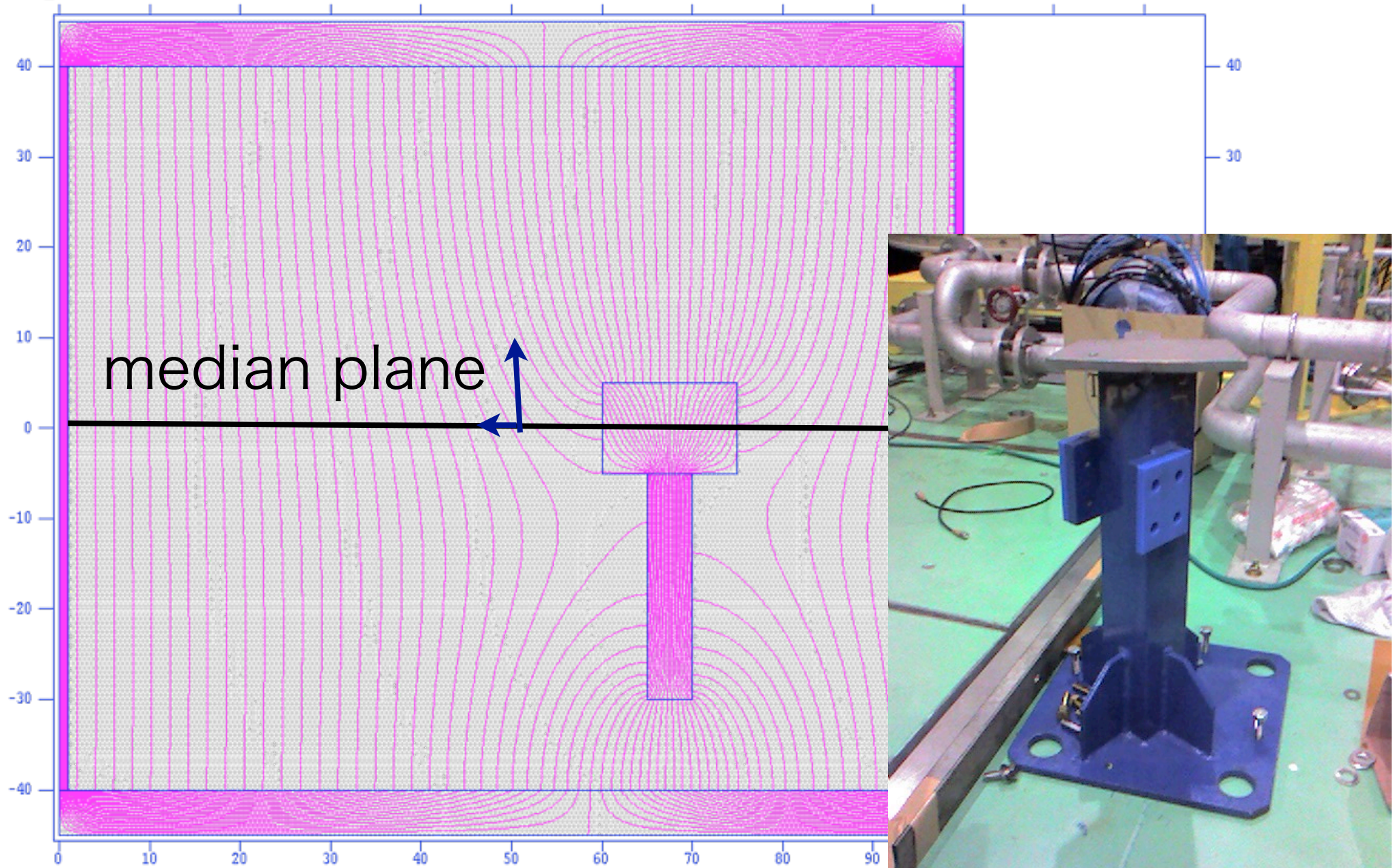

# Bunch monitor signal at the injection

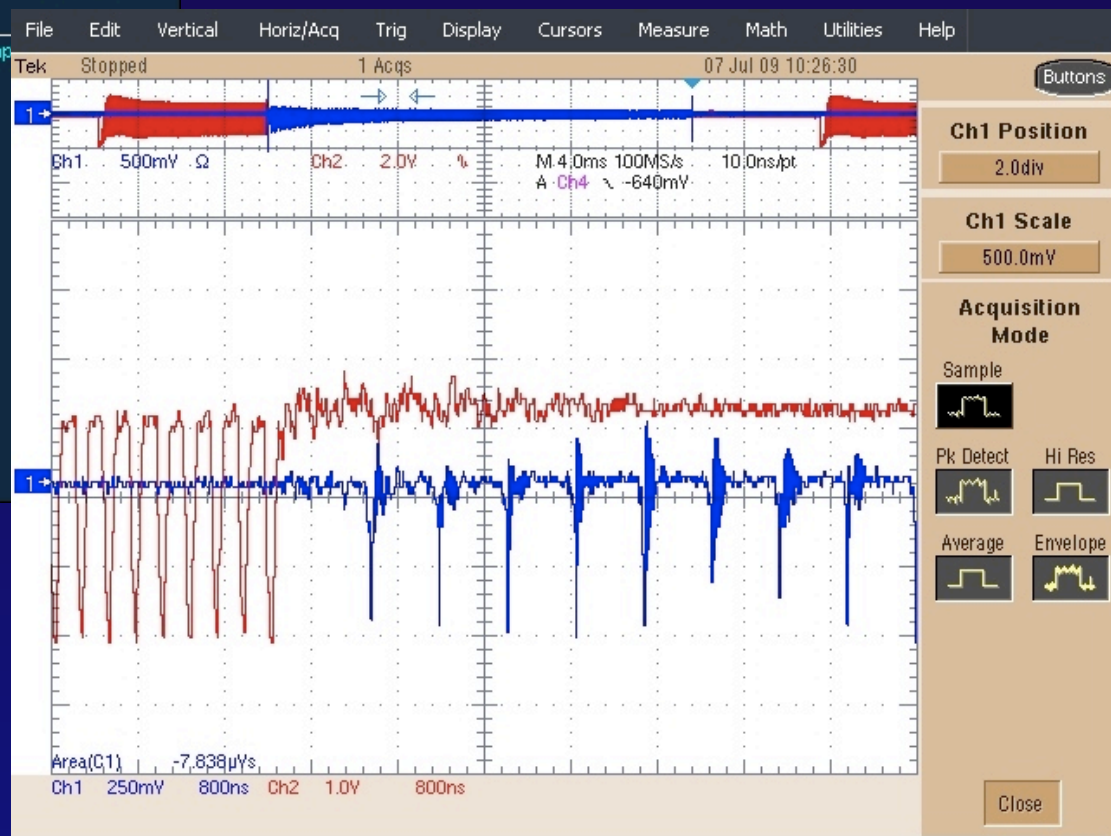
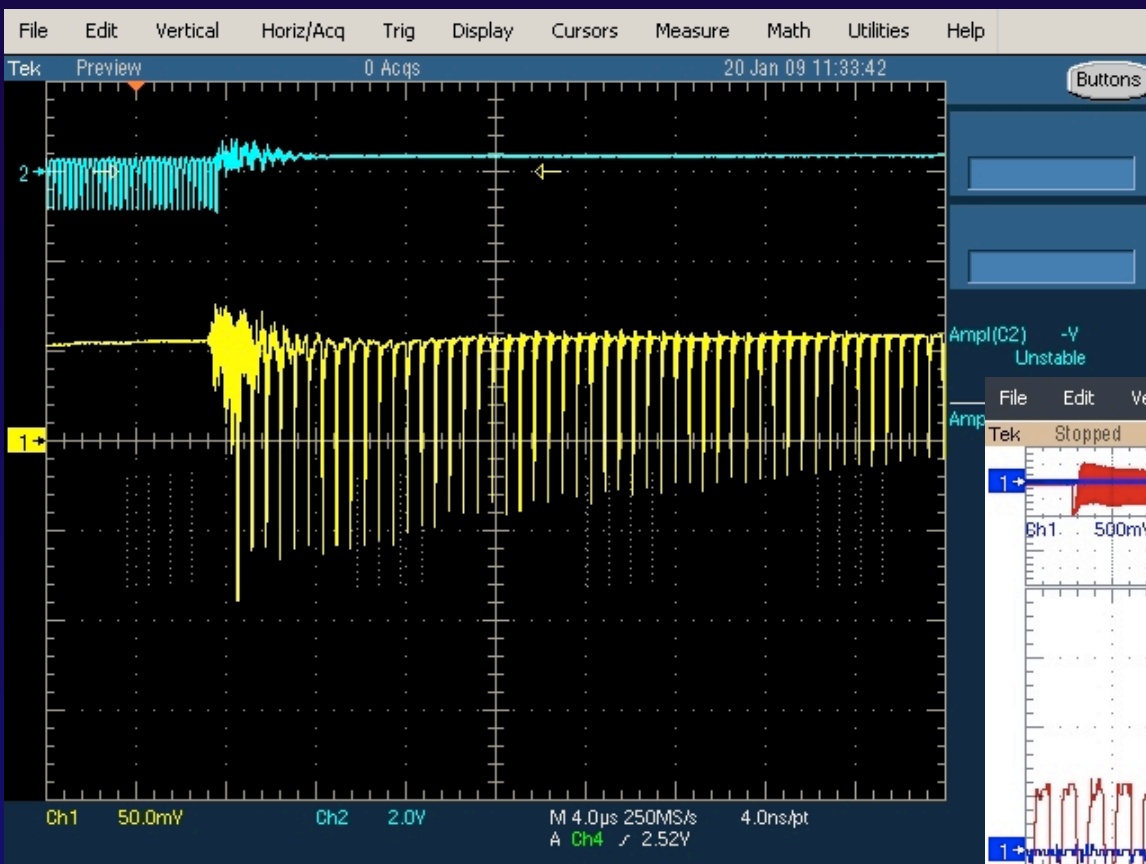

# Main ring operating point

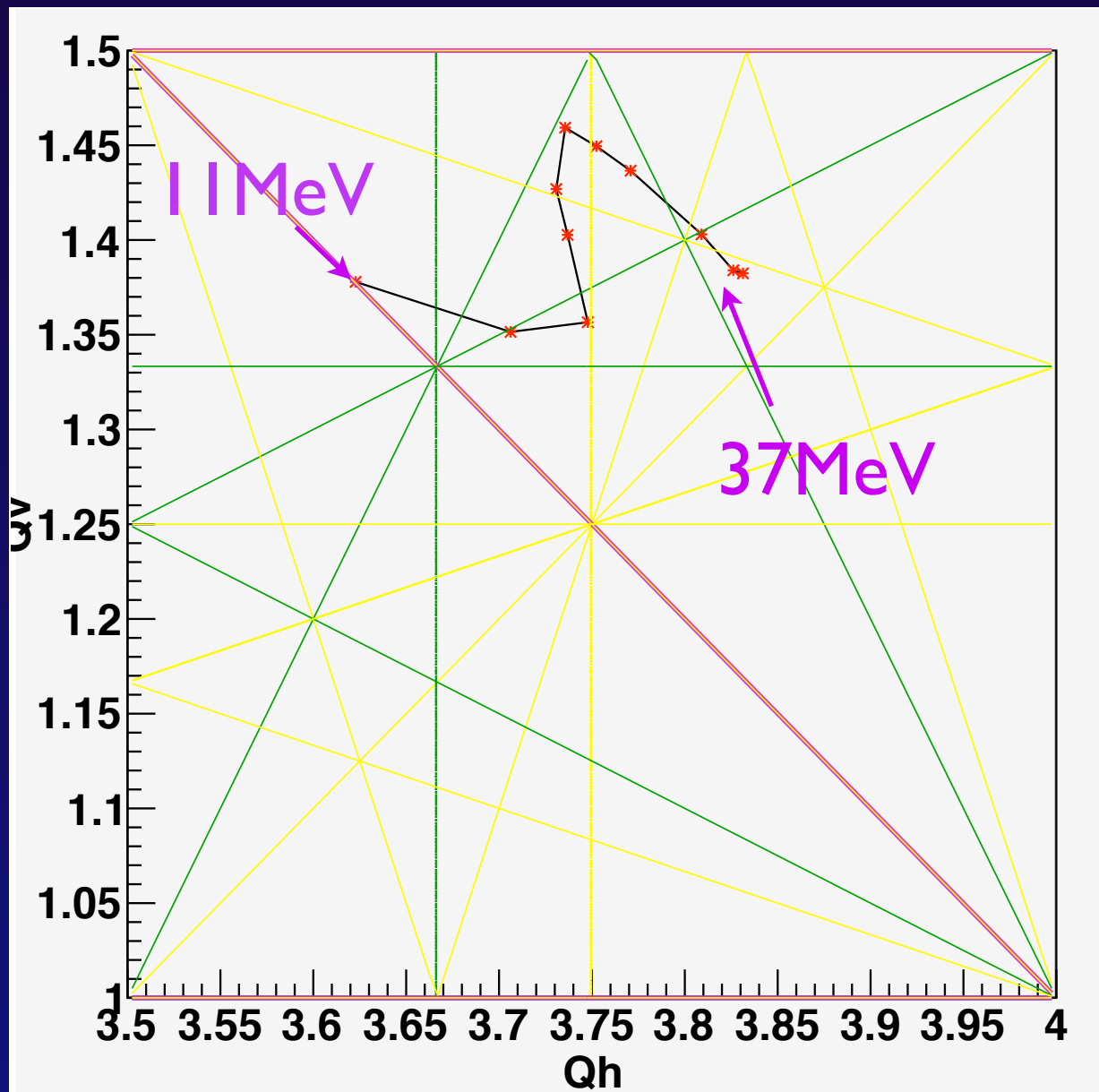

# extraction orbit

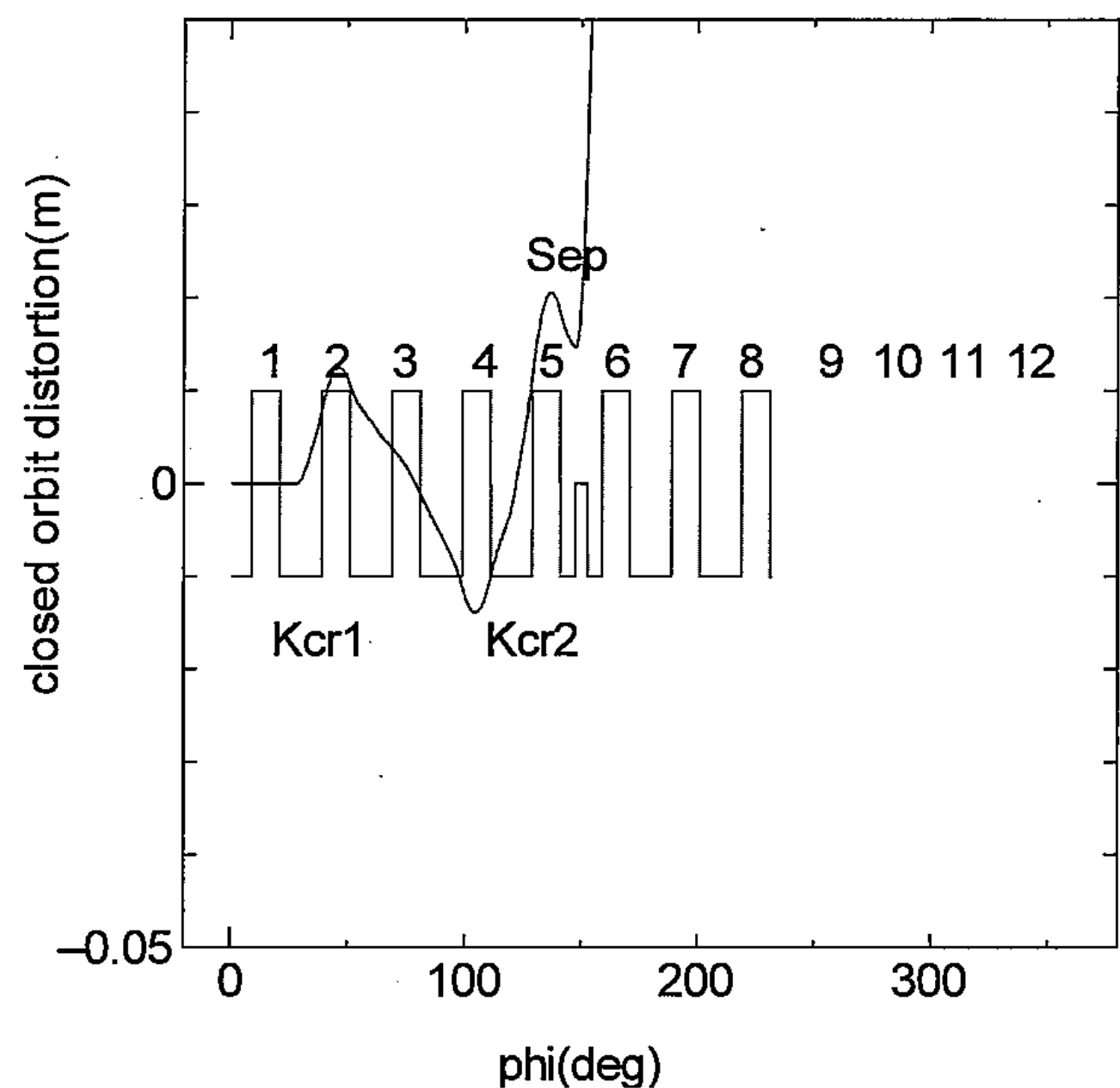

# Extraction kicker and septum

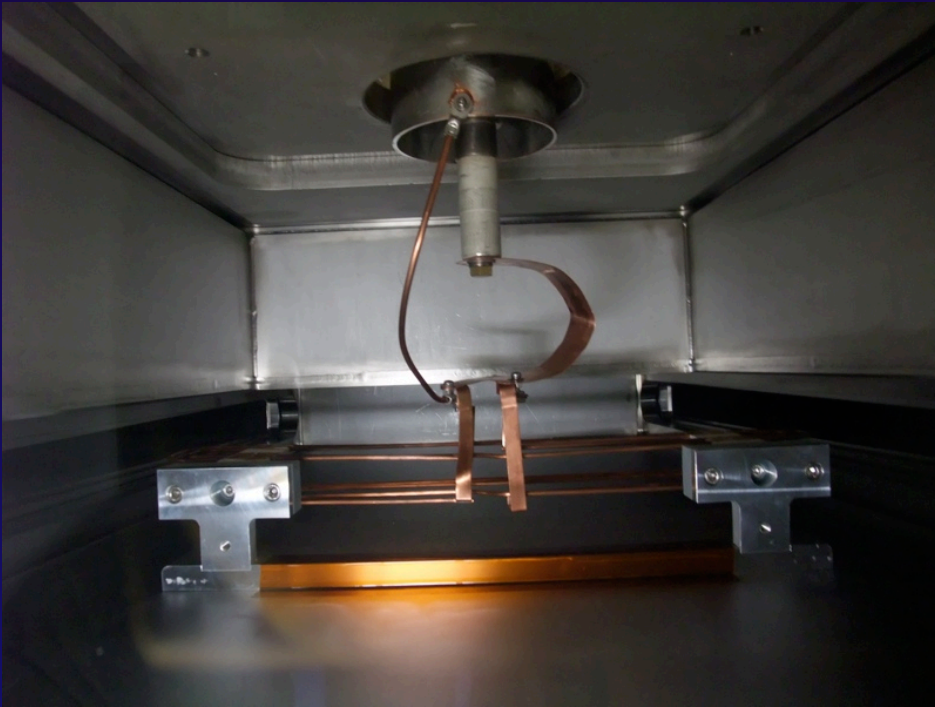

air core kicker  
4-turn coil

## Eddy current type septum

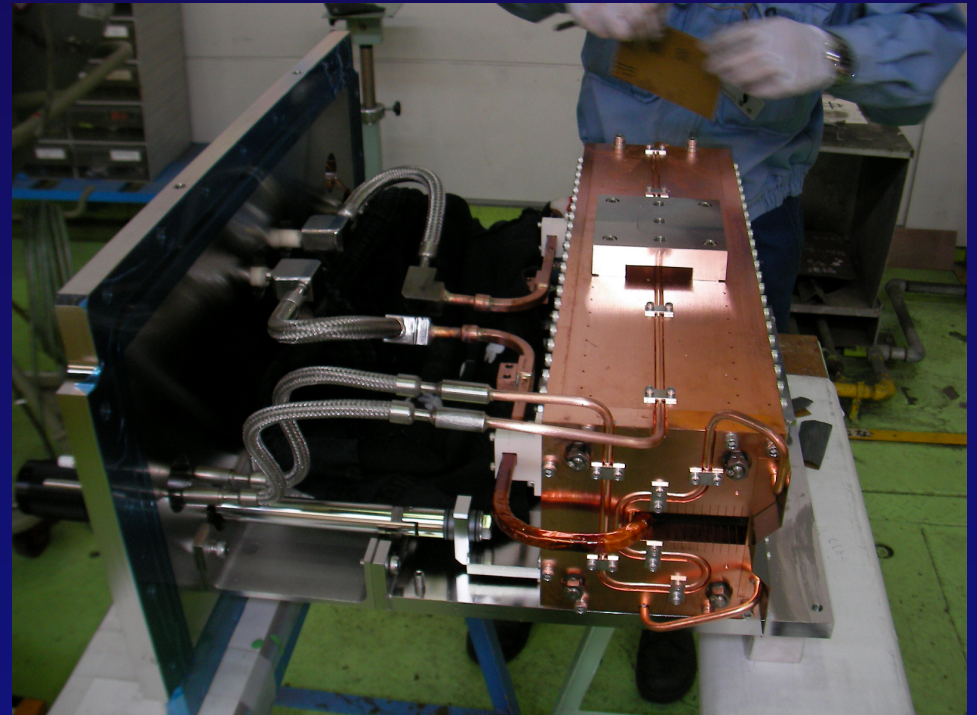

# extracted beam

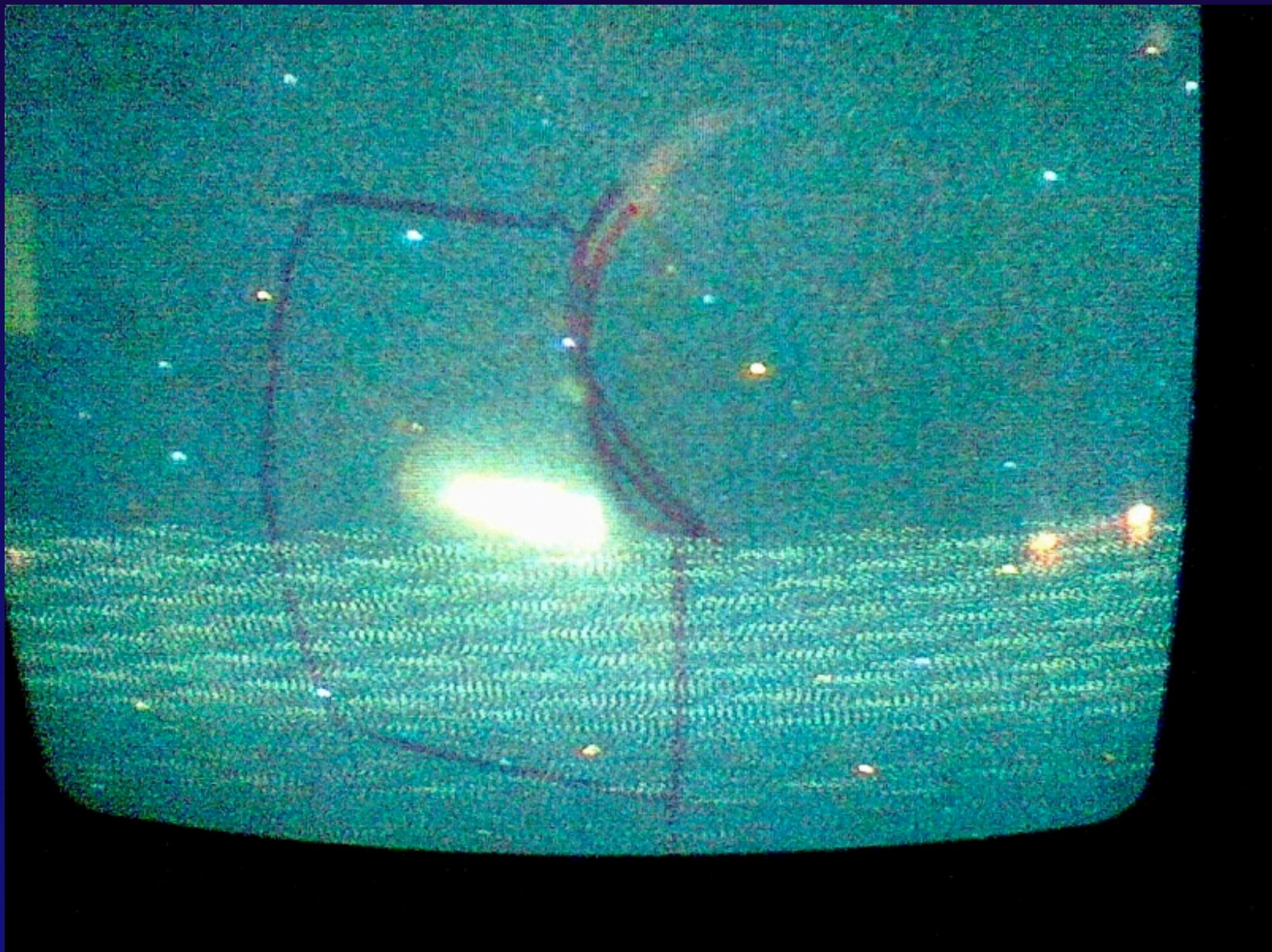

# Pulse shape of extraction kickers

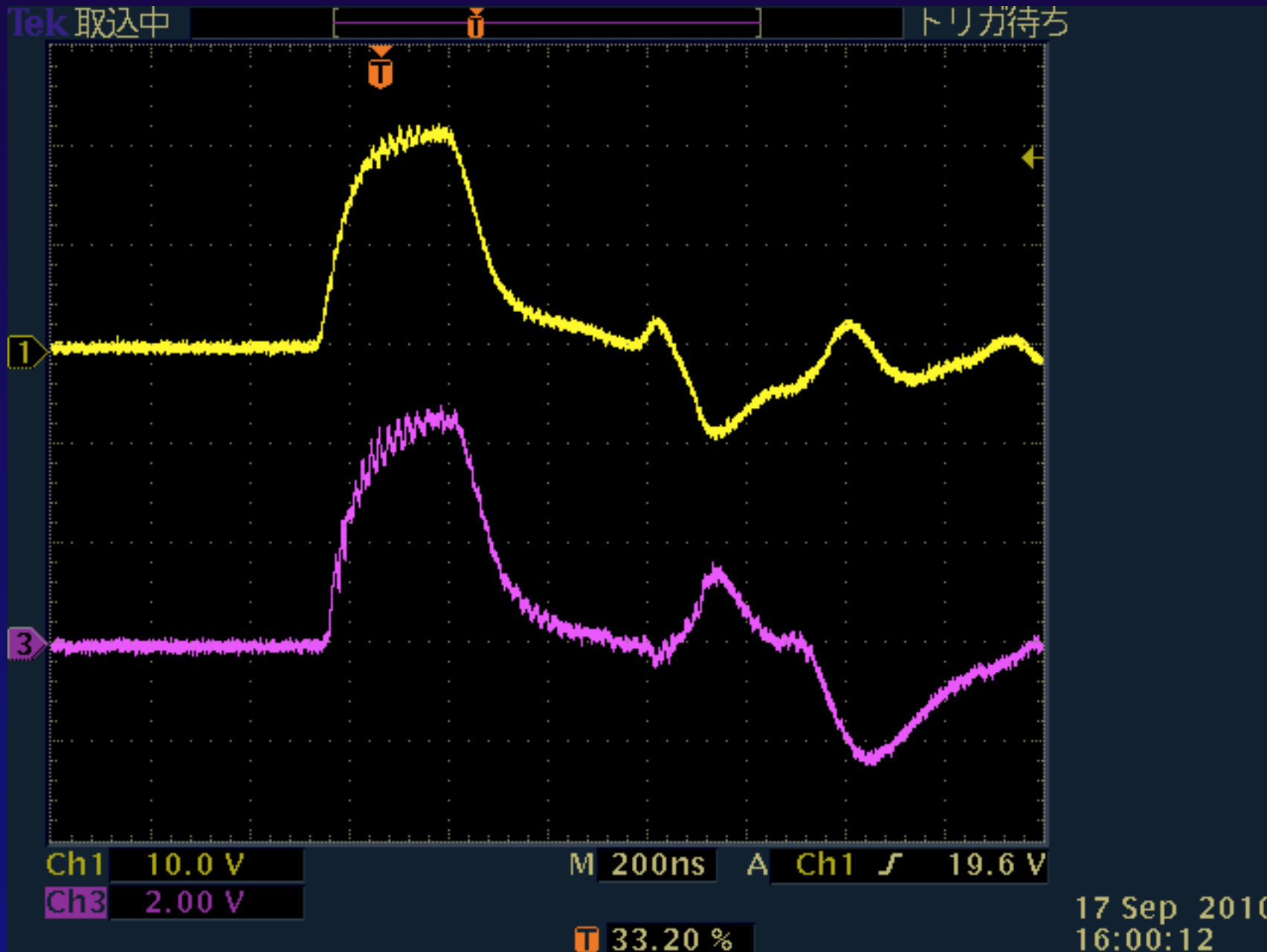

# Pulse shape of extraction septum



# Bunch monitor signal thru acceleration

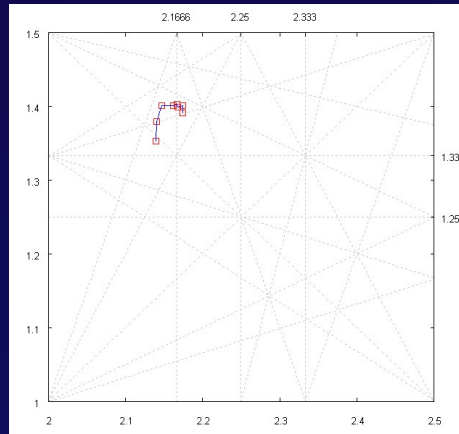
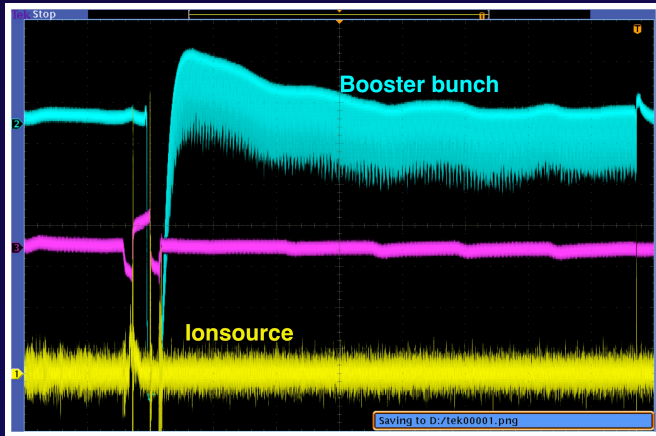

No beam loss  
 $E=11.5\text{MeV}$   
 $I=1.5\text{nA}$

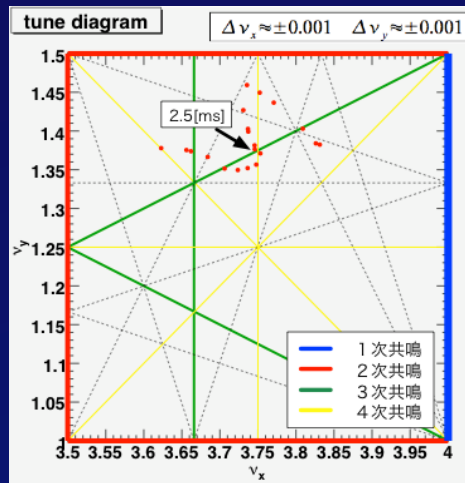
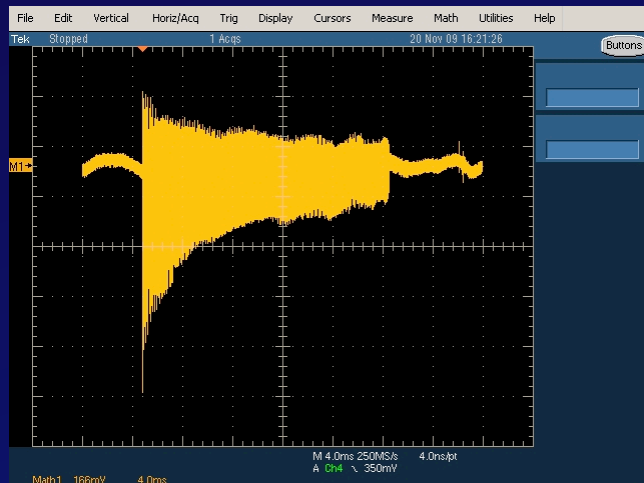

$E=100\text{MeV}$   
 $I=>0.1\text{nA}$   
 (limited by  
 radiation safety)

Rapid beam loss caused by resonance  
 $Q_x - 2Q_y = 1$  at 2.5ms. → Field correction  
 Slow beam loss ← longitudinal

# Accelerator Performance

- Injector

- Capability of variable energy has been demonstrated

- Booster

- Stable beam performance has been obtained

- Main Ring

- Significant beam loss is observed at 4ms from injection
  - ▶ Mismatch of rf bucket → increase rf voltage
  - ▶ Transverse resonance → tune adjustment ( F/D ratio, additional core)

# Contents

- Feature of ADSR
- ADSR studies in KURRI
- Design and Performance of FFAG Complex
- **ADSR Experiments in KURRI**
- Future plans of FFAG Complex
- Summary

# ADSR Experiment Setup

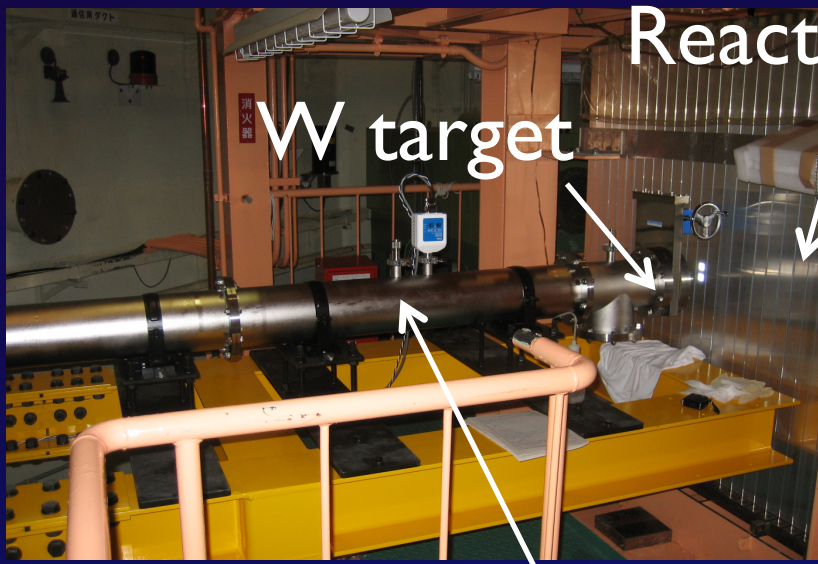

Beam transport line

## ◆ Conditions

- FFAG Accelerator :  
100 MeV Protons  
30 Hz repetition rate  
~a few pA intensity  
Tungsten target  
(80mm diameter,  
10mm thickness)

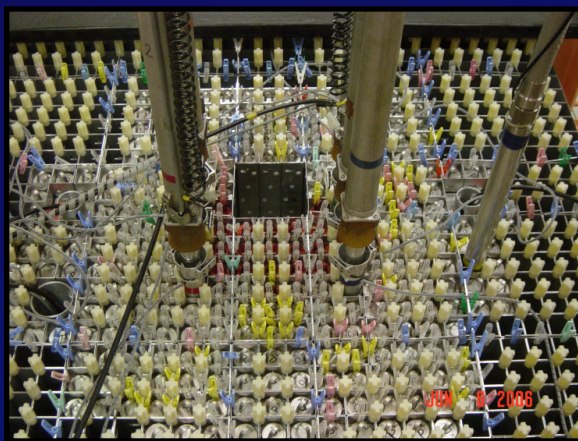

Subcritical fuel system

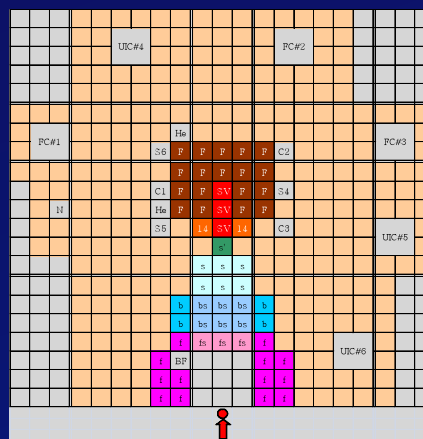

- KUCA A-Core :  
93% enriched uranium  
Polyethylene moderator/reflector  
C1~C3 control rods fully inserted

# World's First ADSR Experiment (March 4, 2009)

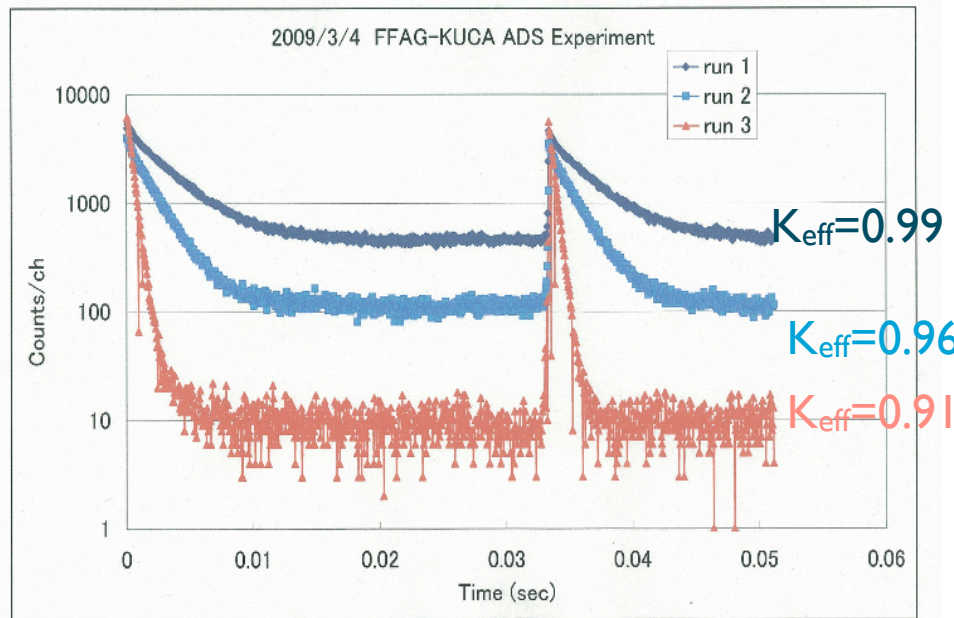

Two components in the neutron counting rate:  
the fast component decaying exponentially and  
the slow component caused by delayed neutrons  
almost constant in time.

The presence of the delayed neutrons indicates  
that neutrons generated through nuclear fission  
reaction inside the fuel system; it tends to have  
higher level with higher  $k_{eff}$  which means  
shallower subcriticality of the fuel system.

# Thorium-loaded ADSR Experiment (March 3, 2010)

## ◆ Proton Injection in Thorium Core

- FFAG Accelerator :

100 MeV Protons

30 Hz repetition rate

~30-50 pA intensity

Tungsten target

(80mm diameter, 10mm thick)

- KUCA A-Core with Th :

Natural thorium metal fuel

No moderator or Graphite moderator



# Verificaiton of Th Fission Reaction

## ◆ Th Plate Measurement by HFGe Dectector ( Th plate Dim. : 2" x 2" x 1/4")

- 22 isotopes with 5% fission yield & gamma-ray emission were selected
- The existence of only Sr-92 was found with very small peak
  - **Very difficult** to find the evidence of thorium fission reaction

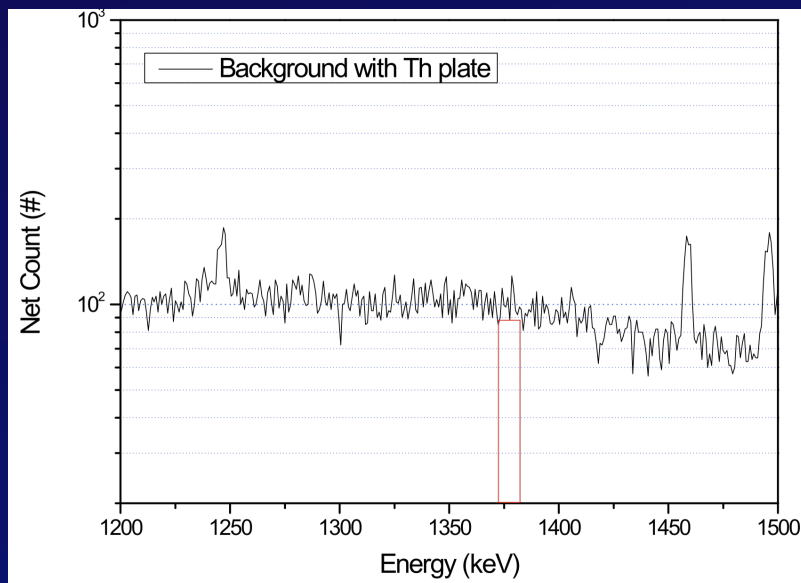

Count without Thorium Fuel Irradiation

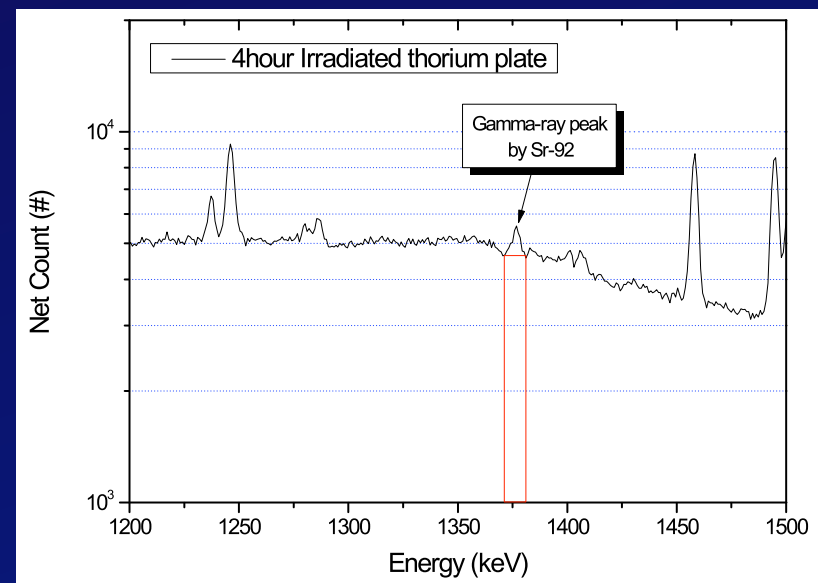

Gamma peak by Sr-92 after Th Irradiation

# Contents

- Feature of ADSR
- ADSR studies in KURRI
- Design and Performance of FFAG Complex
- ADSR Experiments in KURRI
- Future plans of FFAG Complex
- Summary

# Future Plans

Recently in KURRI, a high intensity pulsed neutron source is desired not only for ADSR studies but for research using high intensity neutrons.

Using FFAG system as a proton driver for the neutron source, two major upgrade paths are considered:

- the intensity enhancement by changing the injector system;
- the energy upgrade up to 700MeV to enlarge the number of spallation neutrons.

# H- injection

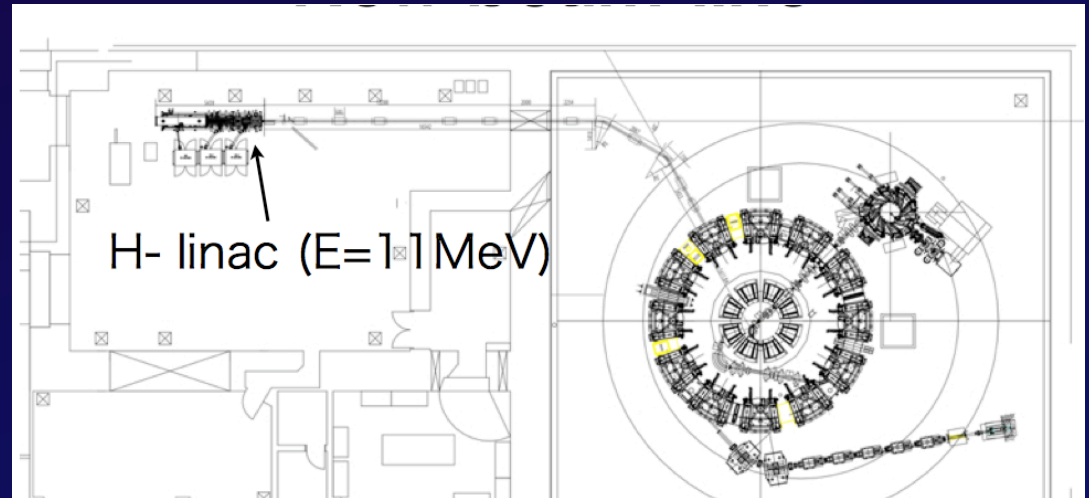
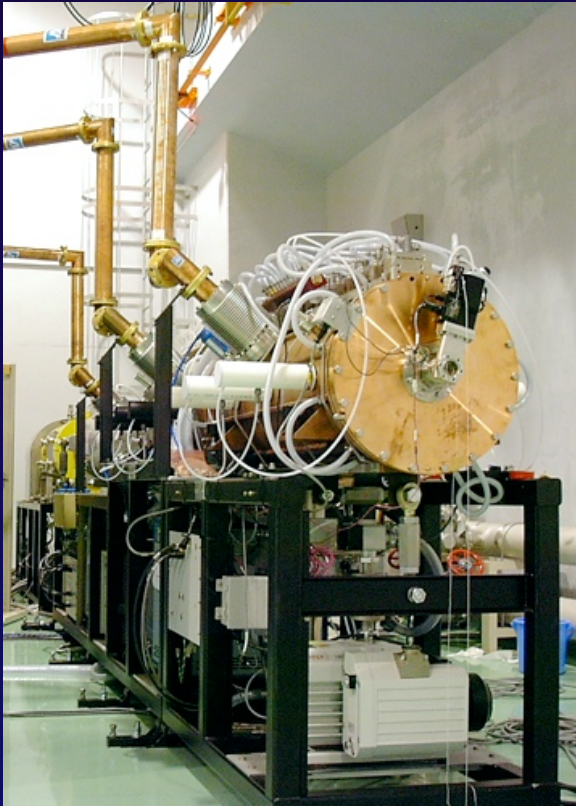

In an ordinary multi-turn injection of proton beam, accumulated beam intensity is limited by the transverse acceptance at the inflector. However charge changing H- injection scheme can get rid of such a limitation. The space charge limit of the accumulated proton beam is estimated **120 nA** at a repetition rate of **100 Hz**.

For the injector of this scheme, **ERIT injector system** composed of RFQ and DTL can be used; it is installed in the same building.

The linac accelerates H-beam up to **11 MeV** which is about the same as the injection energy of the main ring.

The beam line will be constructed in the summer of 2010, and the beam commissioning is planned to be **done by the end of 2010**.

Ion : H-  $E_{\text{ext}}$  : 11 MeV

Beam Pulse width(MAX) : 100  $\mu\text{s}$

Peak beam current : > 5 mA

→  $3.1 \times 10^{12}$  [ppp] Rep. rate : 1 Hz ~

200 Hz Average beam current : > 100  $\mu\text{A}$

$$\Delta B/B=0 \quad -2 \leq \theta_{\text{foil}} \leq +1$$

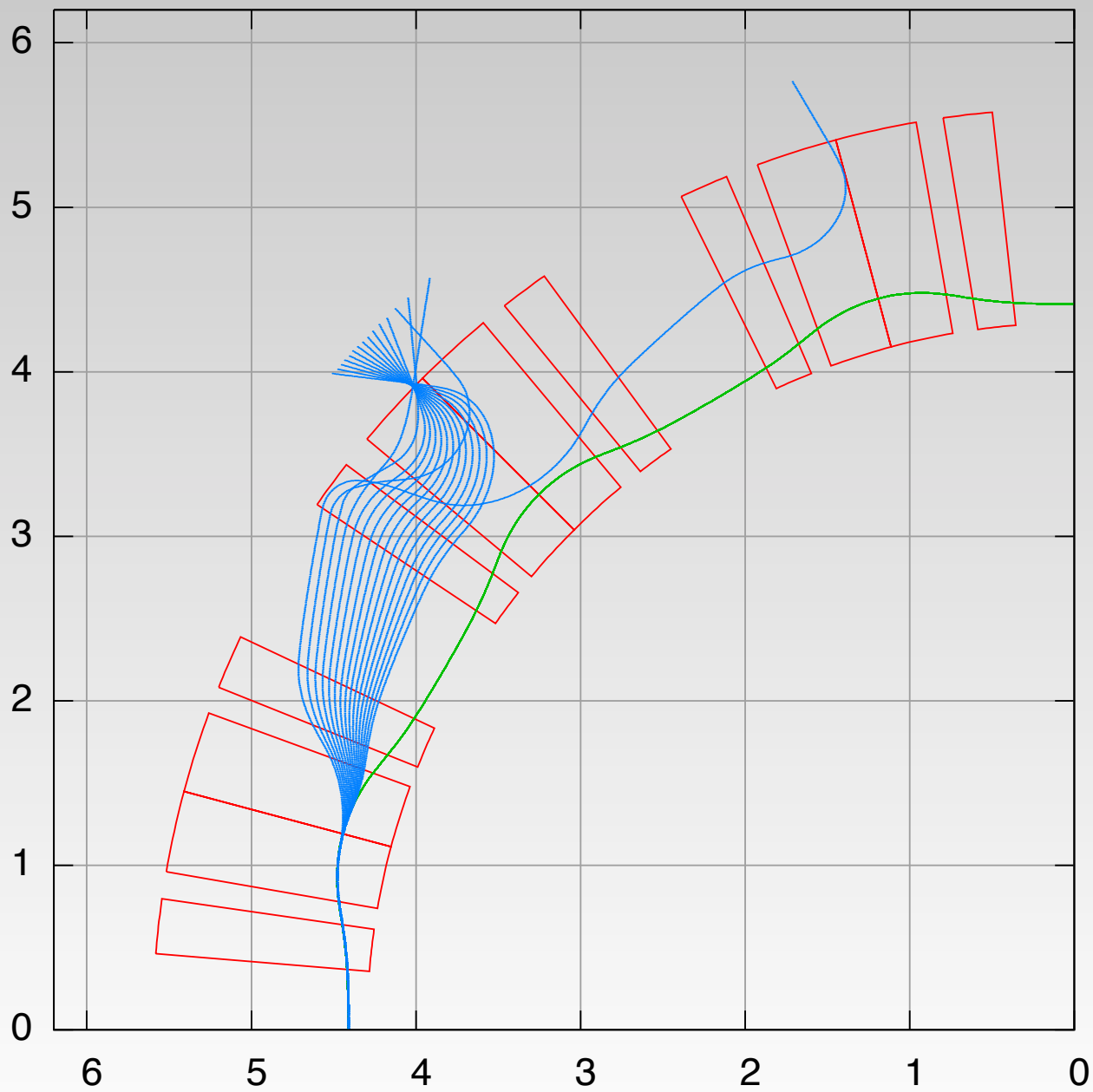

# Reference orbit of the injected beam

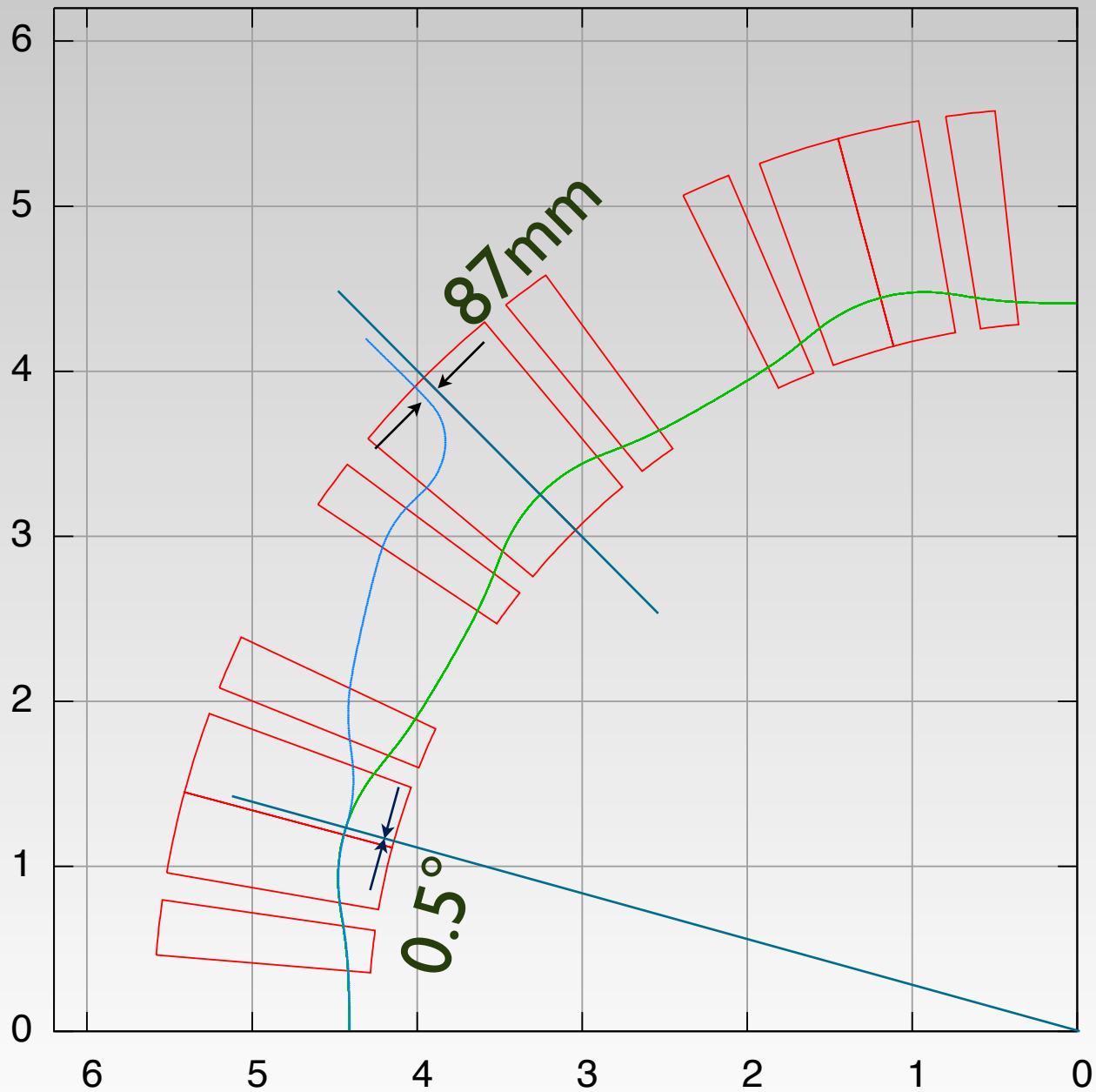

# 700MeV FFAG RING

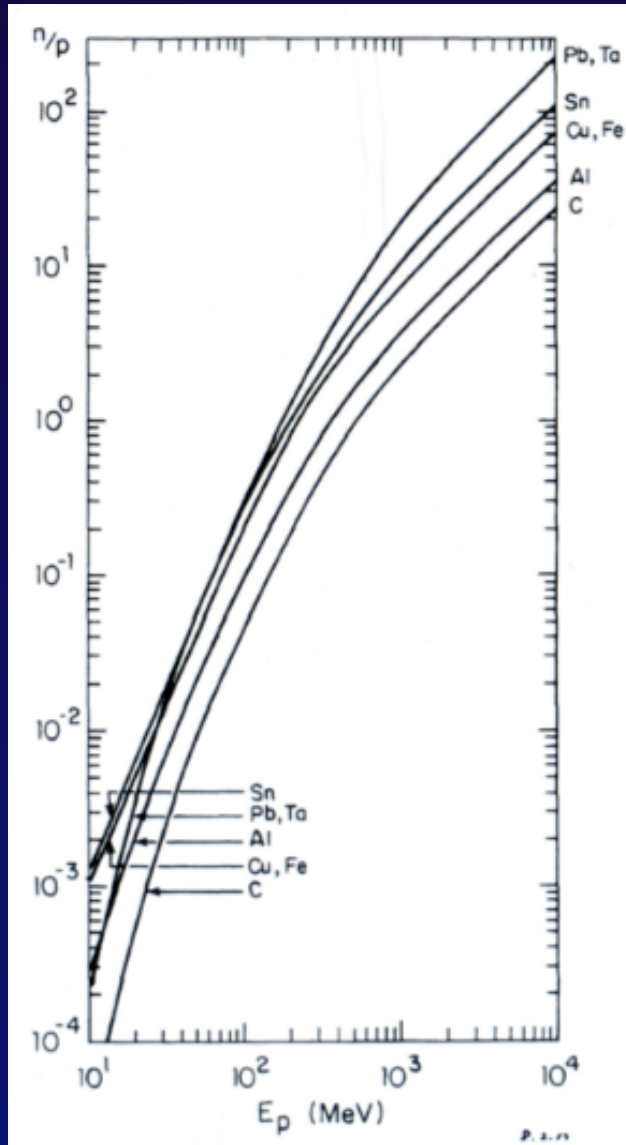

Neutron yield vs proton energy

Number of neutrons produced through the nuclear spallation process is strongly dependent on the beam energy of the primary protons. If the beam energy is increased from 100MeV to 700MeV, the number of neutrons corresponding to single primary proton is **increased by a factor of 30.**

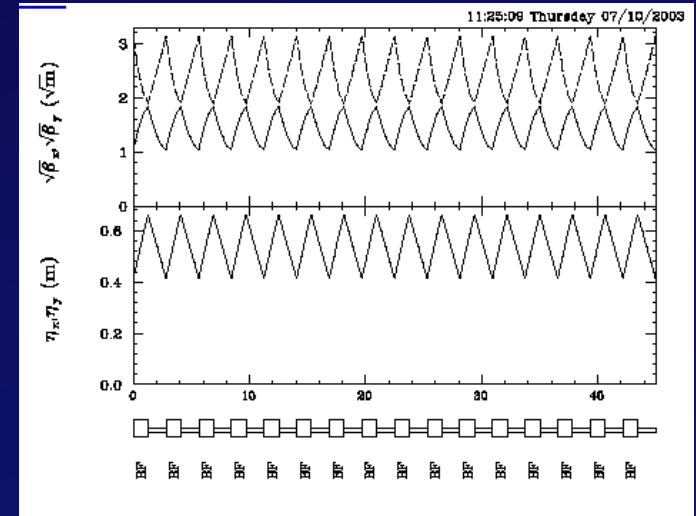

Lattice functions of 700MeV ring

## Parameters of 700MeV ring

Lattice	16-cell spiral
Field index $k$	12
Energy	150 - 700 MeV
Average orbit radii	6.6 - 7.2 m
Magnetic field	1.5 T



# Machine schedule in KURRI

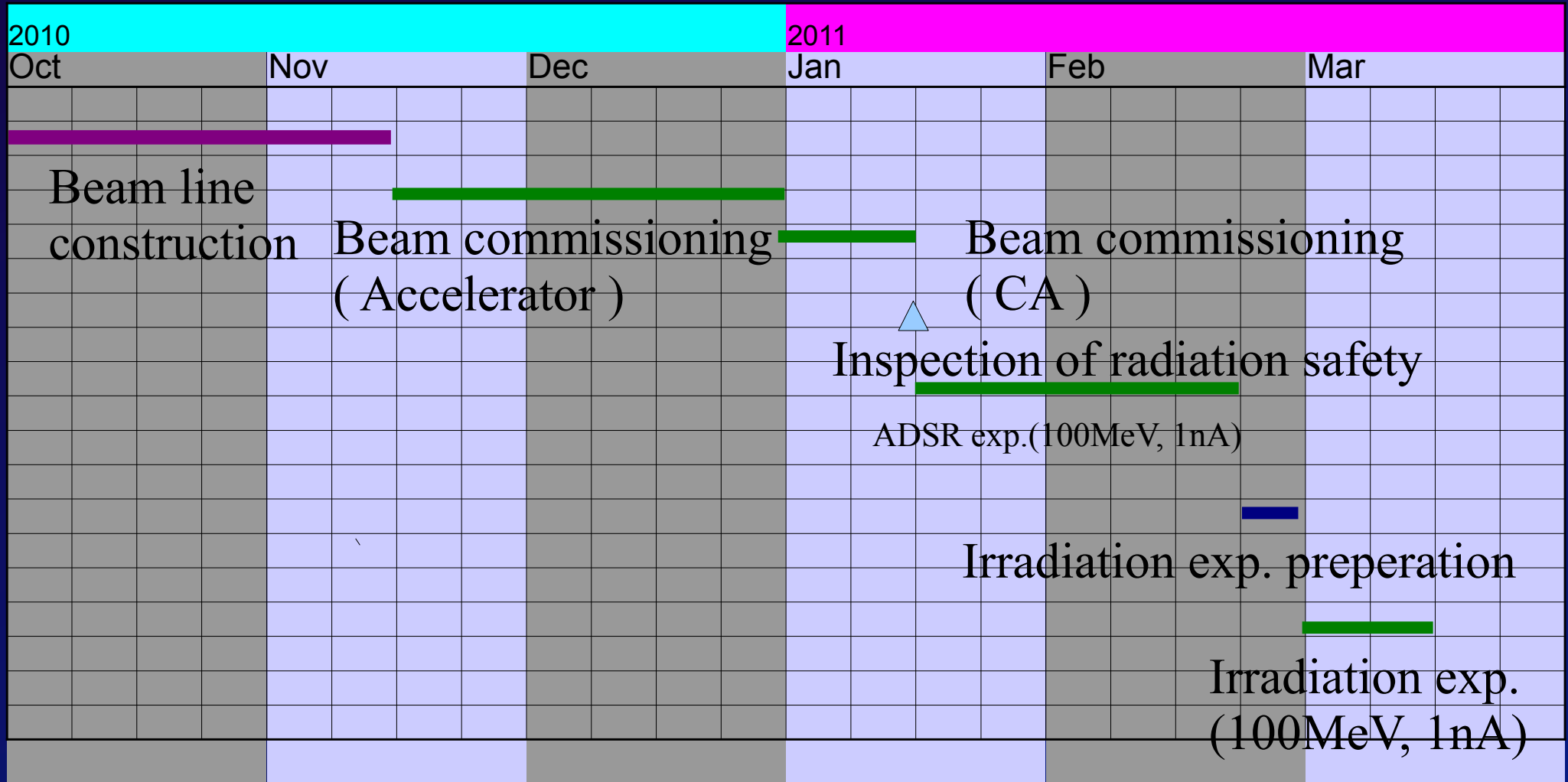

# Summary

1. In KURRI, the FFAG accelerator complex for the ADSR study has been constructed.
2. 100 MeV proton beam from the main ring has been delivered to the sub-critical core in KUCA. World's first ADSR experiment has been successfully started on March 4, 2009.
3. In these experiments, we have obtained evidence of the chain reaction induced by the spallation neutrons produced by the high energy proton beam.
4. Not only for higher performance for the ADSR experiments but for the pulsed neutron source, intensity upgrade program using H<sup>-</sup> injection for present main ring has been started.
5. In addition to the existing FFAG accelerator complex, a 700MeV spiral FFAG ring is now under consideration.

Thank you  
for your Attention