



FFAG



Non-scaling FFAG Designs for ADSR and Ion Therapy

C. Johnstone

Fermilab/Particle Accelerator Corporation

FFAG10

KURRI

Japan

10/25 – 10/31/ 2010



Quick Guide to Fixed-Fielding Alternating Gradient FFAGs

- Simplest Dynamical Definition:
 - FFAG is ~ a cyclotron with a gradient; beam confinement is via:
 - Strong alternating-gradient (AG) focusing, both planes: **radial sector FFAG**
 - normal/reversed gradients alternate (like a synchrotron)
 - Gradient focusing in horizontal, edge focusing in vertical: **spiral sector FFAG**
 - vertical envelope control is through edge focusing (like a cyclotron)
 - the normal gradient increases edge focusing with radius /momentum (unlike a cyclotron)
 - A cyclotron can be considered the lowest-order FFAG
- Types of FFAGs:
 - **Scaling:**
 - B field follows a scaling law as a function of radius - r^k (k a constant;) present-day scaling FFAGs: Y. Mori, Kyoto University Research Reactor Institute
 - **Nonscaling:**
 - Linear (quadrupole) gradient; beam parameters generally vary with energy (EMMA FFAG, Daresbury Laboratory, first nonscaling FFAG)
 - Nonlinear-gradient; beam parameters such as machine tune can be fixed (as in a synchrotron)



FFAG

FFAGs and their Variations

Scaling FFAGs (spiral or radial-sector) are characterized by geometrically similar orbits of increasing radius, imposing a constant tune (field and derivative gradient scale identically with r). Magnetic field follows the law $B \propto r^k$, with r as the radius, and k as the constant field index.

$$B = B_0 \left(\frac{r}{r_0} \right)^k = B_0 \left(1 + \frac{k}{r_0} x + \frac{k(k-1)}{2! r_0^2} x^2 + \dots \right)$$

Field expansion: k determines multipole order;
 Comments: the lower the k value, the more slowly field increases with r and the larger the horizontal aperture, but the more linear the field composition and dynamics.

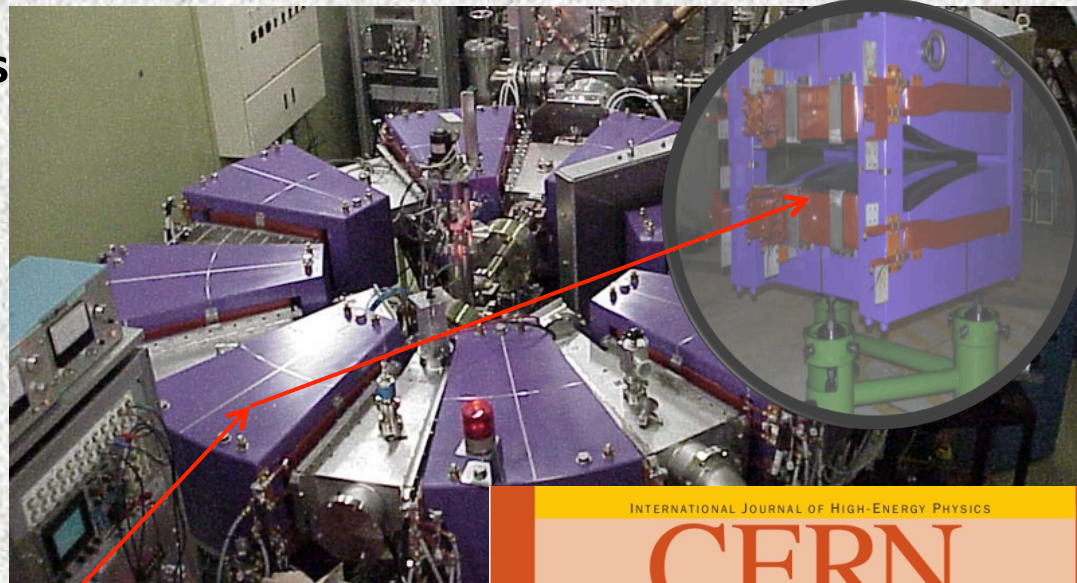

Spiral Sector: example: more compact; positive bend field only. Vertical focusing controlled by edge crossing angle.

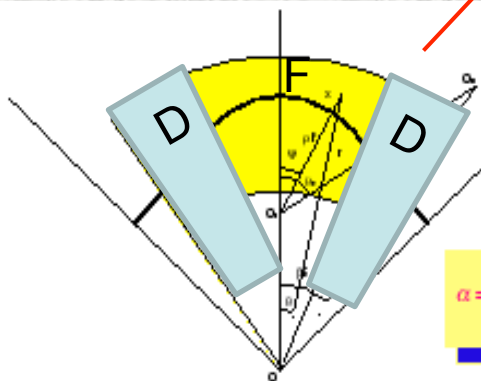

Radial Sector: example: This is a triplet DFD cell; there are also FDF, FODO and doublets. In a radial sector the D is the negative of the F field profile, but shorter.

$$\alpha = \frac{1}{k+1} : \text{momentum compaction factor}$$

INTERNATIONAL JOURNAL OF HIGH-ENERGY PHYSICS

CERN COURIER

VOLUME 48 NUMBER 7 SEPTEMBER 2008

ANR

RACCAM

A route to rapid acceleration

CERN
LHC gets onto the starting blocks p5

LHC FOCUS
Nobel expectations at Lindau meeting p29

ENERGY
Chris Jewell-Smith looks to the future p33



FFAG

Linear nonscaling FFAGs for rapid acceleration

Linear-field, nonscaling FFAGs.

Ultra-compact magnet aperture, proposed and developed for High Energy Physics (Neutrino Factories and Muon Colliders), relaxes optical parameters and aims only for stable acceleration. In general they are not suitable for an accelerator with a modest acceleration system and accelerate only over a factor of 2-3 range in momentum.

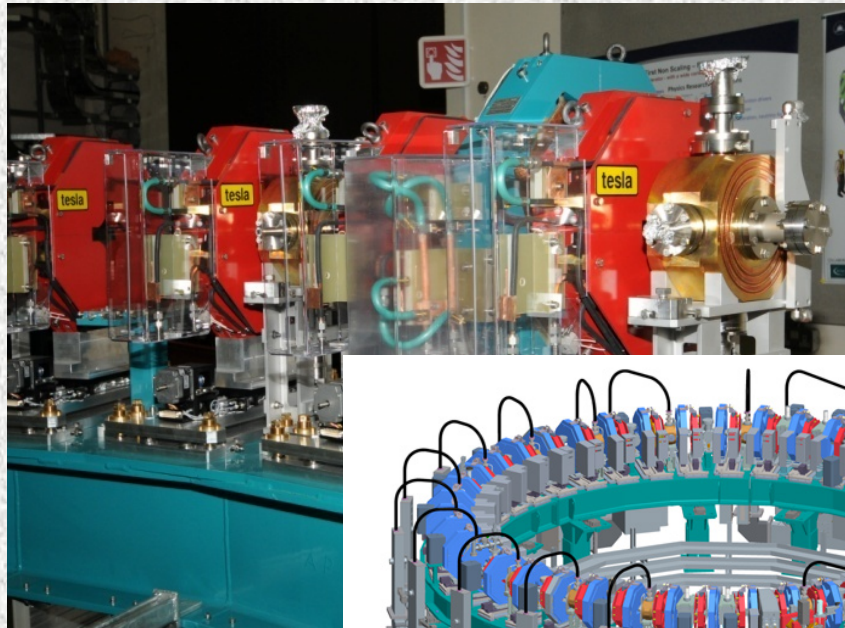

EMMA – world’s first nonscaling FFAG, @Daresbury Laboratory, commissioning, late December, ‘09

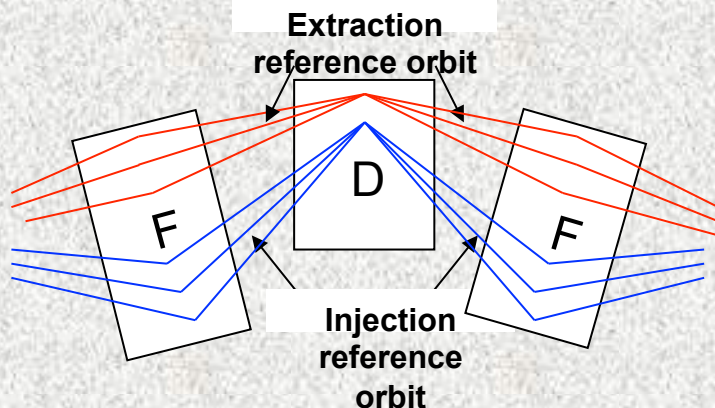
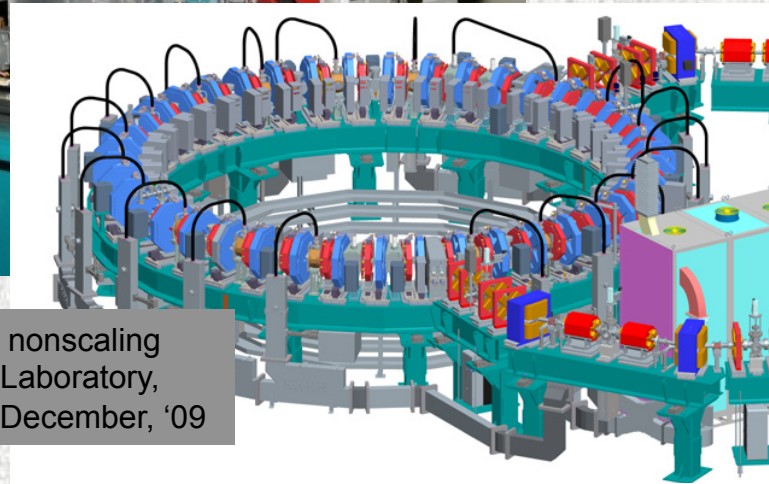

Cartoon of orbit compaction: nonsimilar orbits, nonconstant tune, resonance crossing

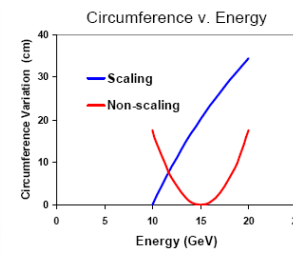
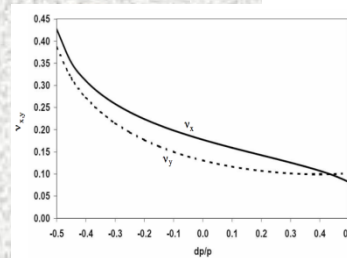

$$C(p) = C(p_m) + \frac{12\pi^2}{e^2 q^2 N L_{FD}} (p - p_m)^2$$

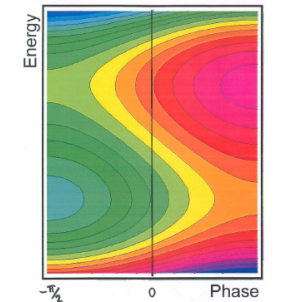

Characteristics– tune sweep/unit cell, parabolic pathlength on momentum (small radial apertures); serpentine (rapid) acceleration – beam “phase-slips”, crossing the peak 3 times, accelerating between rf buckets



FFAG

Tune-stable nonscaling FFAGs for slow acceleration

Tune-stable, nonscaling FFAGs

•Tune is strongest indicator of stable particle motion – allowing particles execute periodic motion eventually returning to the same transverse position relative to a reference orbit. Constraining the tune can be sufficient to design a stable machine.

•Release of other linear optical parameter allows flexibility and optimization both in cost and complexity of the accelerator design; i.e. simpler magnets, strong vertical focusing, for example

•*Tune Stable Nonscaling FFAGs have either linear or nonlinear field profiles and/or edge contours*

Two lattice approaches

- 1) Machida version - which uses a scaling law truncated at decapole, rectangular magnets , (not discussed here, see PAMELA project) and
- 2) Johnstone version – The most general form of a radial sector : allowing independent, unconstrained field and edge profiles between two combined-function magnets.

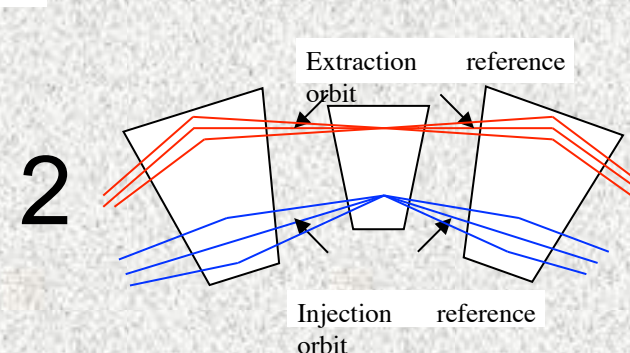
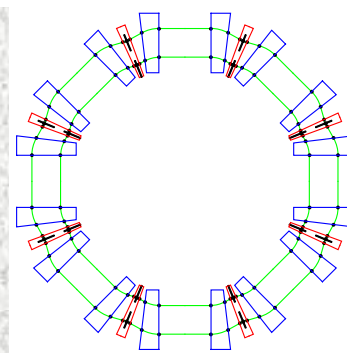
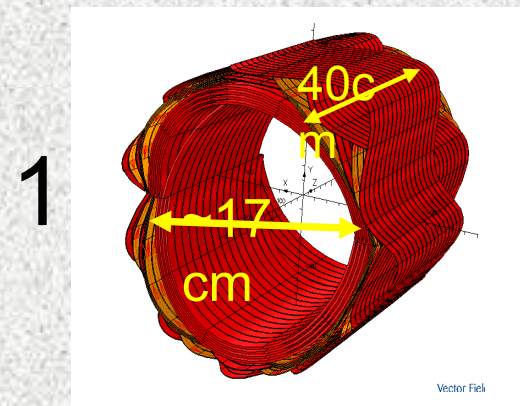
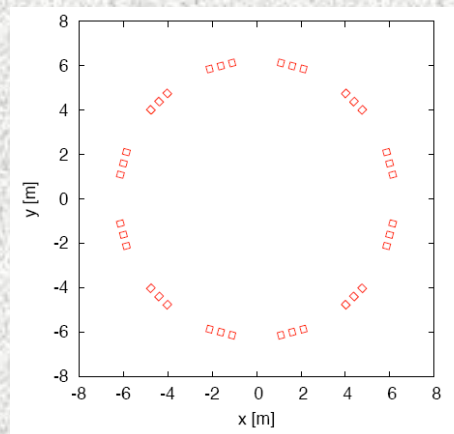



FFAG

Principles of Beam Transverse Focusing: a short review

1. Centripetal focusing (*used in Cyclotrons + FFAGs*) :

- Pathlength variation in dipole body field, bend plane only
- Horizontally focusing or defocusing for FFAGs with reverse bends (radial sector).

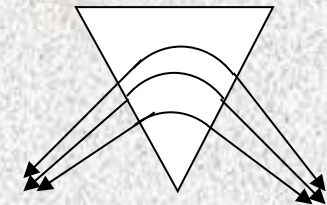

2. Edge focusing (*used in Cyclotrons + FFAGs*)* :

- Quadrupole-like: focusing horizontally, defocusing vertically, or vice versa, or no focusing depending sign of the B field and on entrance angle (defined relative to the normal to the magnet edge).

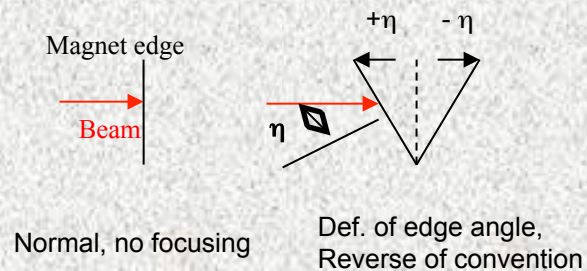

3. Field -gradient focusing (*used in Synchrotrons + FFAGs*)

- Body gradient, fields components > dipole; AG envelope focusing:

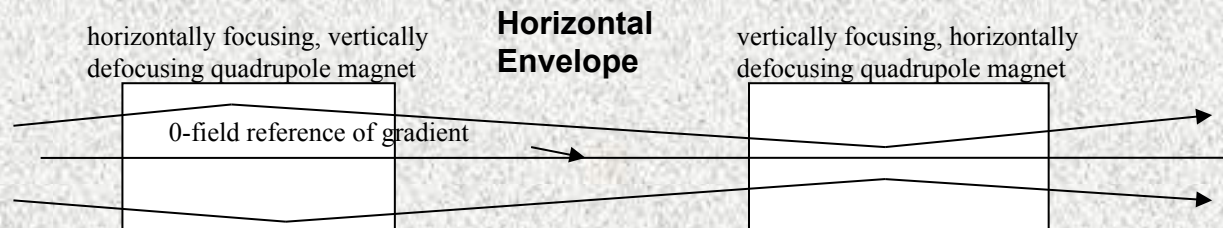



FFAG

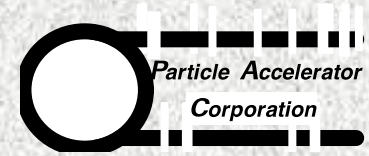

Basic Structure of FFAGs

With strong focusing why are FFAGs stable over a large range in momentum (unlike a synchrotron which can stably circulate a dp/p of only a percent in a fixed magnetic field)

- Completely periodic – like a cyclotron
 - Periodicity permits closed geometry and repetitive, adiabatic optical solutions over a tremendous range in momentum;
 - Strong focusing allows “long” straights to be integrated in the unit cell; unlike a cyclotron
 - Generally no specialized insertions (difficult to match over different momenta)
- All lattices are simple, single lens structures based on the FODO cell
 - max and min alternate in opposing planes - even the so-called doublet and triplet FFAGs are FODO-like.
 - Single lens structures are optically stable over a large range in momentum.
 - No telescope-based FFAGs.
- Short cells; short focal lengths.
 - The stronger and shorter the cell; the more adiabatic the optical functions, and the larger the stable momentum range.
 - Use of Combined Function magnets minimize unit cell length and optimize dynamic range



Thin lens transverse focusing terms

- The relevant strength terms, therefore, in an arbitrary-order multipole CF magnet used in a FFAG are:
 - For the horizontal, the three terms are

$$1/f_F = \overset{\text{synchrotron}}{\underbrace{k_F l}} + \overset{\text{cyclotron}}{\underbrace{\frac{\vartheta}{\rho_F} + \frac{\eta}{\rho_F}}}$$

with ϑ is the sector bend angle, η the edge angle (edge angle is assume small so tangent is approximated), length, l , is the F half - magnet length and k_F is the "local" gradient for an arbitrary order field.

- For the vertical only the quadrupole gradient, $k_D l$, and the edge term are available
- The different focusing terms can be varied independently to optimize machine parameters such as footprint, aperture, and tune in a FFAG



FFAG

To summarize beam envelope control (in the thin Lens Limit):

1. Centripetal (*Cyclotrons + FFAGs*) :

- bend plane only, horizontally defocusing or focusing
 - Strength $\propto \theta/\rho$ (bend angle/bend radius of dipole field component on reference orbit)

2. Edge focusing (*Cyclotrons + FFAGs*) :

- Horizontally focusing / vertically defocusing, vice versa, or no focusing depending on field at entrance and entrance angle
 - Strength $\propto \tan \eta/\rho$, (or $\sim \eta/\rho$ for reasonably small edge-crossing angles)

3. Gradient focusing (*Synchrotrons + FFAGs*) :

- Body gradient, fields components $>$ dipole:

$$B = a + bx + cx^2 + dx^3 + \dots \quad \Rightarrow \quad B' = b + 2cx + 3dx^2 + \dots$$

- Linear field expansion, constant gradient
 - » **Synchrotrons + linear-field nonscaling FFAGs (muon accelerators)**
- Nonlinear field expansion up to order k, magnitude of gradient increases with r or energy:
 - » **Scaling FFAGs**
- Arbitrary nonlinear field expansion, magnitude of gradient increases with r or energy:
 - » **Nonlinear Non-scaling FFAGs**

Edge crossing angles are kept deliberately small in large multi-cell synchrotron rings. This term becomes increasingly important for and causes problems in small synchrotron rings.



FFAG

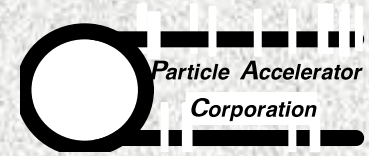

More on gradient/edge-focusing

- Understanding the powerful interplay between gradient and edge focusing is critical to understanding the potential of FFAGs
 - In cyclotrons,
 - horizontal envelope control is through the centripetal term
 - Centripetal term increases with radius/pathlength/momentum in the cyclotron magnets
 - Vertical envelope control is through edge focusing / field shaping at the magnet edges
 - proportional to the constant dipole field; more difficult to increase, much weaker than horizontal focusing in cyclotrons
 - In FFAGs,
 - the gradient increases both the horizontal (centripetal) and vertical (edge focusing) with radius/momentum
 - This last point is very important for FFAGs because it allows the field, orbit location, and important machine parameters such as tune to be more independent and strongly controlled than in cyclotrons



FFAG

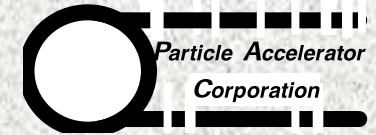

Progression of the NS FFAG Design

- **Linear (constant gradient)**
 - Rectangular magnets EMMA machine at Daresbury Laboratory
 - Non-constant machine tune, significant investment in high-power rf
 - EMMA has 19 rf cavities in a 42-cell ring.
 - Maximum acceleration range: factor of 4 (practically 2-3)
- **Linear (constant) gradient + edge contour**
 - Edge contour on magnets to stabilize tune
 - Increase of momentum range to a factor of 6
- **Nonlinear gradient + edge contour**
 - Arbitrary order combined with magnet edge contour
 - Ultra-constant tune
 - Slow acceleration supported - low-power, but swept-frequency rf system
 - Increase of momentum range as high as 44 in a more compact footprint
- **Nonlinear gradient – isochronous**
 - Ultra-constant tune
 - Gradient/magnet shape adjusted for isochronous orbits - simple low-power fixed-frequency rf system



FFAG

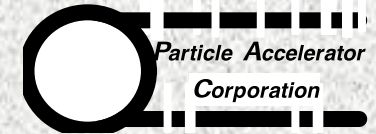

Example: Linear (constant) Gradient NS FFAG with rectangular magnets

- Unconstrained tune
- Resonance crossing: valid for rapid acceleration
- Ideal for secondary, short-lived particles (muons, short-lived isotopes)
- Highly compact orbits
- Linear Dynamics, largest acceptance of any accelerator

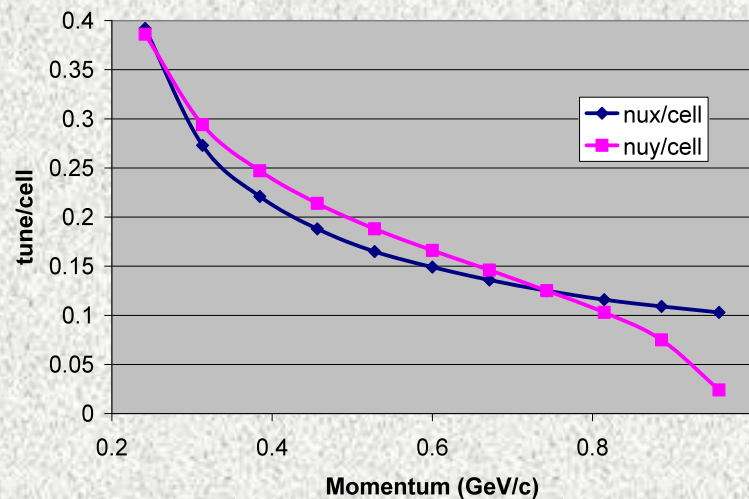

tune variations in a nonscaling FFAG

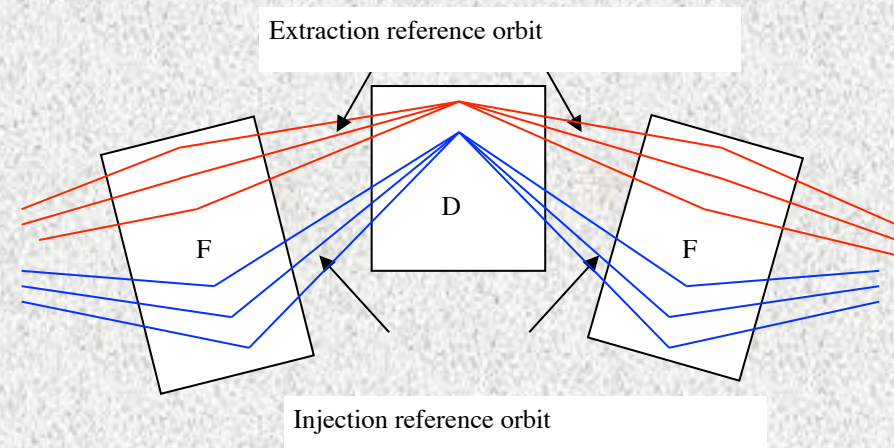

1½ cell of a nonscaling, linear-field FFAG for muon acceleration showing the compression of orbits in particular in the center magnet.



FFAG

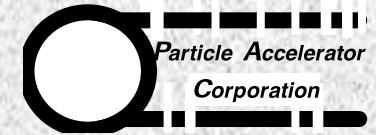

EMMA: The first NS FFAG

- 10-20 MeV electron prototype (for multi-GeV muons)
 - Design and energy provides a test of rapid acceleration; i.e. multi-GeV muon accelerators
 - Enormous predicted acceptance $\sim 30,000\pi$ mm-mr
 - 42 cells, 19 1.3 GHz rf cavities, 10-turn acceleration
 - Resonance crossing
 - Serpentine acceleration
 - Slow acceleration for resonance studies
 - Commissioning started in May, 2010

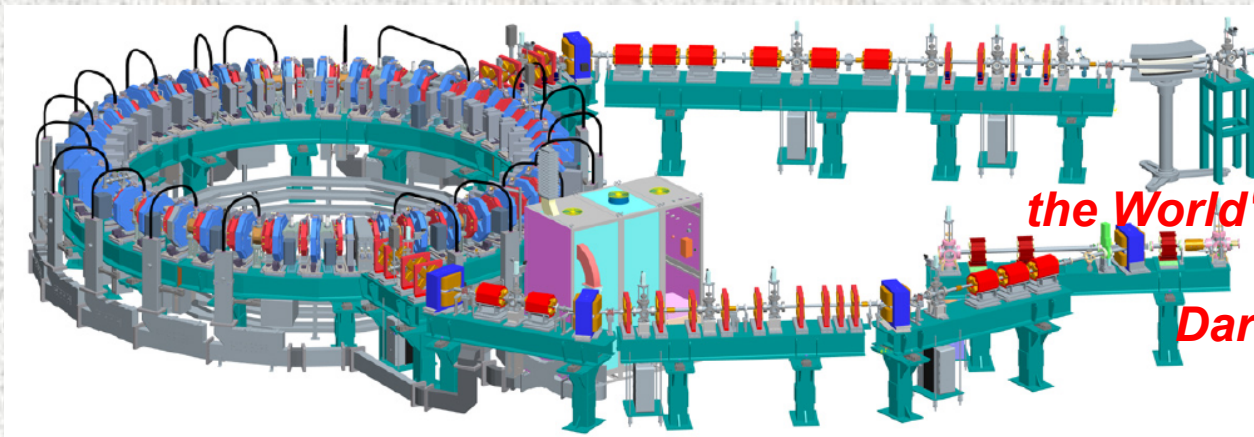

EMMA
the World's First Non-Scaling FFAG
Accelerator
Daresbury, Laboratory



FFAG

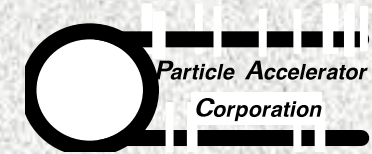

Challenge: Adapting the linear-field, nonscaling FFAG for slow acceleration (medical accelerator)

Considerations

- **Tune** is strongest indicator of **stable** particle motion
 - allows particles in the beam to execute periodic motion relative to a reference orbit
- Constraining the tune can be sufficient to design a stable machine.
- Other design parameters can be released to optimize, for example, cost, complexity and size of the accelerator;



FFAG

Controlling Tune in a linear-field nonscaling FFAG

- Unlike a synchrotron, reference orbits in a fixed-field accelerator always move radially outward with energy.
- Using this property, tune can be controlled in a linear-gradient FFAG by *shaping the edges* of the magnets.
- All three focusing terms are impacted by the edge contour and can be used to manipulate the machine tune in the horizontal:
 - Gradient
 - weak and edge focusing
- Two terms are available for tune control in the vertical,
 - gradient and edge

$$1/f_F = k_F l + \frac{\vartheta}{\rho_F} + \frac{\eta}{\rho_F}$$

$$1/f_V = k_V l + \frac{\eta}{\rho_V}$$

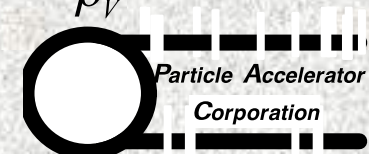



FFAG

Applying an edge contour to a linear-gradient magnet to control tune

- The new approach here is to make use of a gradient and an edge angle on the linear-gradient magnet to enhance not only the integrated strength, but also weak (centripetal), and edge focusing as a function of radius and therefore momentum.
- Contributions from the different strength terms vary with radial position in the F and D magnets – the edge crossing angle actually changes with energy (nonsimilar orbits). The increase in strength of both terms tracks the increase in momentum and stabilizes the tune:

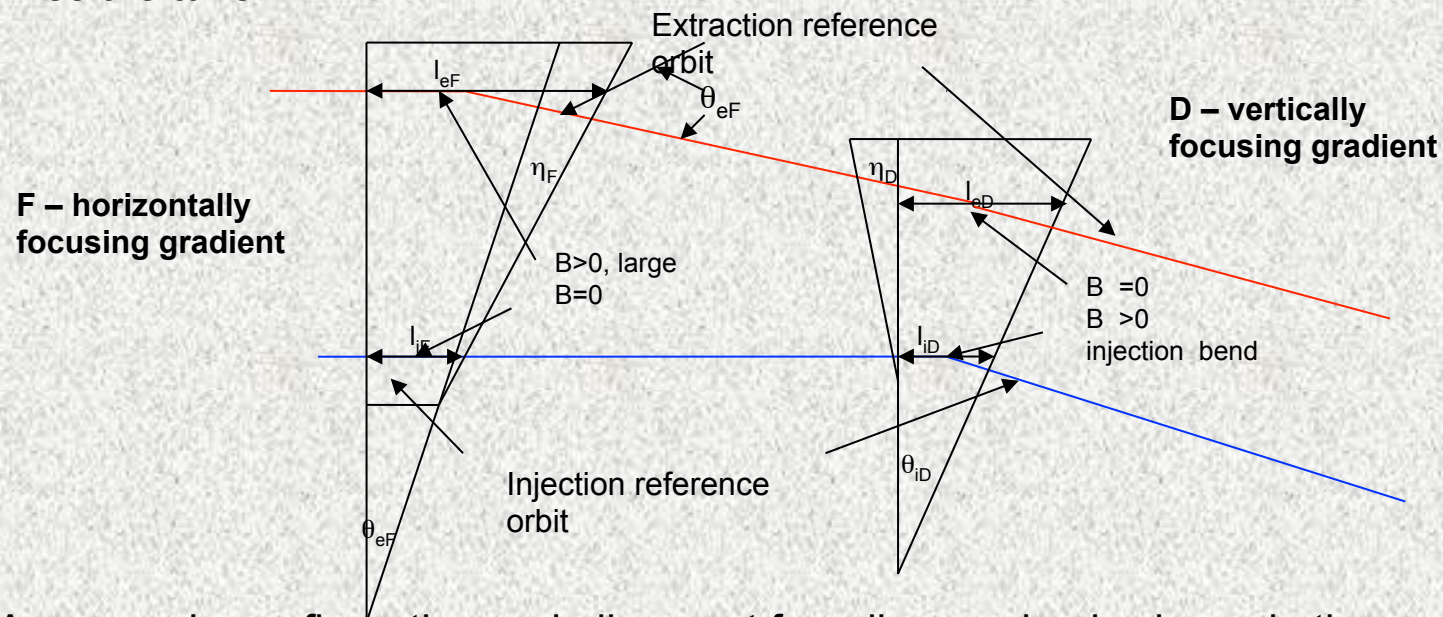

- An example configuration and alignment for a linear edge is shown in the diagram which shows the optics of a *half-cell*.



FFAG

Tune Stability in a linear-gradient nonscaling FFAG with an edge contour

- Linear-fields, constant gradient F and D magnets
- Magnets are shaped with a linear edge contour with only tune constrained
- Dramatic improvement in tune stability – to over a factor of 6 in momentum

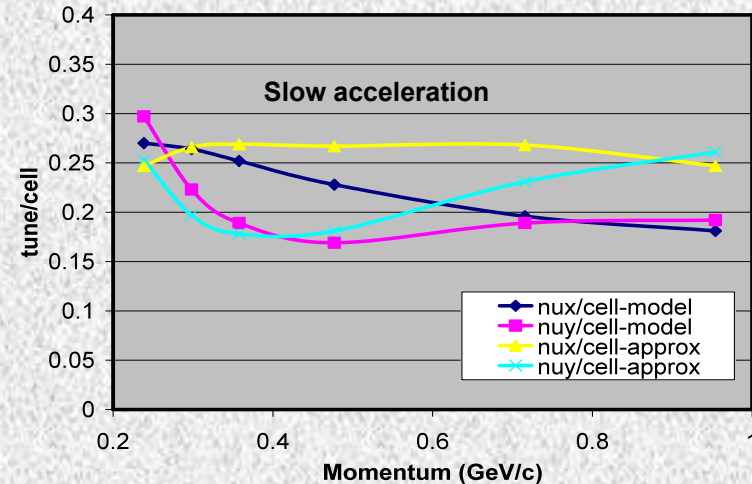
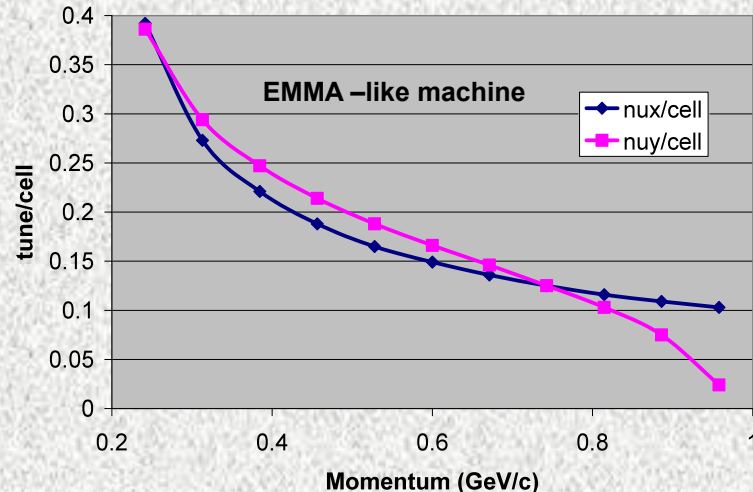

Control of tune variations in a nonscaling FFAG with a constant gradient

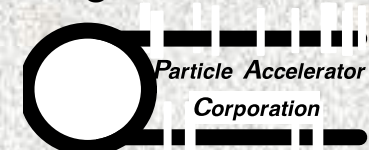



FFAG

The Next Step –

Applying a Nonlinear Gradient to the Nonscaling FFAG

- Compact machines; i.e. footprint, aperture and tune control required higher-order, tailored field profiles
- An arbitrary field expansion has been exceptionally successful
 - Order of magnitude increase in momentum range over initial NS concept
 - an acceleration range of a factor of 44 has been achieved.
 - Large Dynamic Acceptance in predominately nonlinear fields
 - Strong focusing, 90° cell tunes (or higher) achieved in both horizontal and vertical well into the relativistic regime
- Isochronous orbits have been achieved in a nonscaling FFAG by applying an nonlinear gradient and edge contour
- *Isochronous implies CW operation and simple rf systems*

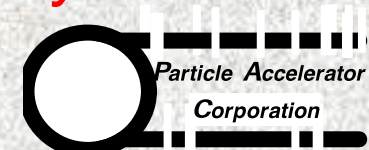



FFAG

The significance of CW Accelerators

- A CW accelerator implies:
 - Fixed magnetic fields
 - 50 Hz is the ~ practical technical limit for pulsed magnet systems
 - Stored power and expense of pulsed supplies can be commercially prohibitive
 - The simplicity of fixed-frequency rf
 - the rotational frequency of orbits is a constant at all energies
- Consequences of non-isochronous orbits
 - Beam is pulsed at the rf sweep rate, not continuous
 - Swept-frequency rf (rf timing is changed to match the revolution time of the beam – the synchrotron and synchro-cyclotron)
 - 50-100 Hz sweep rate for rf frequencies \geq tens of MHz
 - KHz sweep rate for broad-band rf (\sim MHz)
 - slow acceleration, high power consumption





FFAG

The Isochronous Condition

- Dipole fields, i.e. cyclotrons, maintain isochronicity at nonrelativistic energies - that is, at nonrelativistic energies velocity is proportional to momentum and path length is proportional to momentum in a constant B field, therefore path length is proportional to velocity.
- Isochronism can be imposed on the orbits in FFAGs into nonrelativistic energies by requiring the path length remain proportional to velocity, which has an increasingly nonlinear dependence on momentum. The average B field which determines path length as a function of momentum must increase nonlinearly in this energy regime according to:

$$\bar{R}_{extraction} - \bar{R}_{injection} = Aperture$$

$$\bar{R}_{injection} = \frac{\beta_{injection}}{\beta_{extraction}} \bar{R}_{extraction}$$

$$\left(1 - \frac{\beta_{injection}}{\beta_{extraction}}\right) \bar{R}_{extraction} = Aperture$$

*Note that in the nonrelativistic regime, β_{inj} can be $\ll \beta_{ext}$ and aperture \cong machine radius, at relativistic energies, aperture \ll machine radius

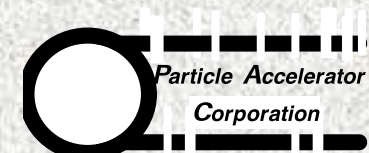



FFAG

Relativistic Isochronous NS FFAGs -

- NS FFAG can retain isochronicity even at relativistic energies
 - Isochronous orbits are proportional to velocity
 - Orbital path length, however, follows the B field proportional momentum not velocity
 - At relativistic energies, momentum is an increasingly nonlinear function of velocity
 - Arbitrary nonlinear field expansion/edge angle can constrain the tune and the orbit/momentum to be proportional to velocity
 - Nonlinear gradient provides very strong focusing at high energy in both planes, unlike the cyclotron

Cyclotron limit
~ 1 GeV protons

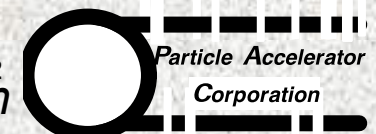
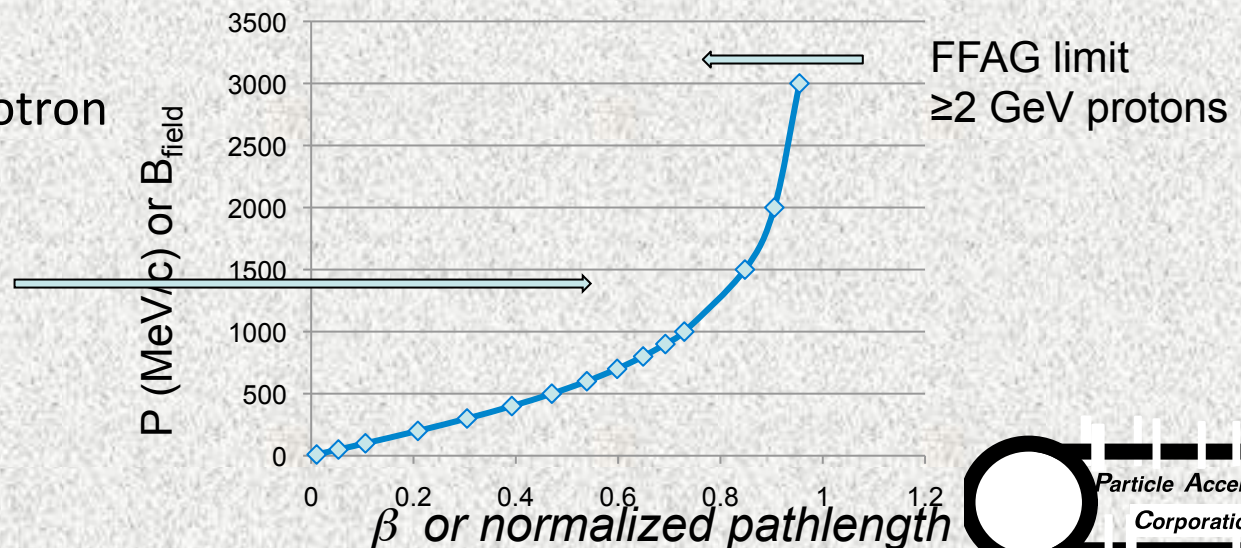



FFAG

Summary of Nonscaling FFAG properties

- By utilizing all conventional modes of transverse focusing for beam and machine parameter control the FFAG can be a powerful hybrid of the cyclotron and synchrotron
 - The FFAG has the potential to combine the best features of the synchrotron and cyclotron
 - **Strong focusing allows synchrotron-like straights – and therefore the low losses associated with synchrotrons especially at extraction**
 - Variable energy extraction – elimination of degraders (to be discussed further)
 - **The simplicity of fixed magnetic fields rather than pulsed operation**
 - Very recently - the simplicity of *fixed-frequency* rather than swept-frequency rf systems; producing reliable, continuous, cyclotron-like beam
- ➔
- **The low operational overhead and simplicity of the cyclotron**

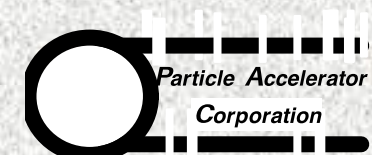



FFAG

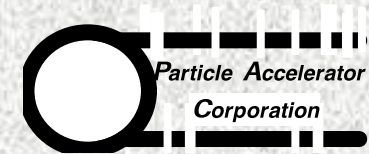

The Simulation Challenges

New accelerator prototypes are often simulated with conventional tracking codes,

- these codes do not provide much flexibility in the field description and are limited to low order in the dynamics.*
- This limitation is inadequate to demonstrate performance in the presence of strong nonlinearities due to edge fields and other high-order effects appear.*
- This is particularly true for the FFAGs where edge crossing and strong bends, or “small-ring” effects can dominate the optics. In the muon FFAGs, the large beam emittances preclude the use of codes which do not include kinematical (or angle) effects in the Hamiltonian. which implies that codes which fully describe the kinematics are necessary .*

The current number of supported design and optimization codes that can adequately describe the complex field and magnet contours for both the scaling and nonscaling FFAG variants is limited to the cyclotron code **CYCLOPS** [1], and the field-map code **ZGOUBI** [2], and recently **COSY INFINITY**[3]

1. R Baartman et al. CYCLOPS. Technical report.
2. F. Meot. The ray-tracing code ZGOUBI. Nuclear Instruments and Methods A, 427:353–356, 1999 and F. Lemuet and F. Meot. Developments in the ray-tracing code ZGOUBI for 6-d mul-titurn tracking in FFAG rings, 2005.
3. M. Berz and K. Makino. COSY INFINITY Version 9.0 beam physics manual. Technical Report MSUHEP-060804, Department of Physics and Astronomy, Michigan State University, East Lansing, MI 48824, 2006. See also <http://cosyinfinity.org>.



FFAG

Recent Advances in Lattice Design and Optimization

- *A powerful new methodology has been pioneered for all fixed-field accelerator optics design (FFAGs and cyclotrons) using control theory and optimizers to develop executable design scripts. These procedures allowed global exploration of all important machine parameters in a simplified lattice.*
- *WITH THIS METHODOLOGY, the stable machine tune for FFAGs, for example, was expanded over an acceleration range of 3 up to 6 in momentum with linear fields and up to 44 with nonlinear fields and this included optimization of complex edge contours, footprint, and magnetic components.*
- *Full evaluation of the simple starting lattice, however, required new advanced simulation tools not existing in current accelerator codes. Such tools have been developed by P.A.C. and implemented as an add-on (FACT) to COSY INFINITY. The FACT (FFAG And Cyclotron Tools) fully develop and expand the complex field and edge profiles to accurately predict and optimize machine performance. An exact, 3D field expansion in polar coordinates is one of the output formats which can be used by other codes.*
- *Starting points from the design scripts are directly imported into and modeled in COSY INFINITY using FACT software.*

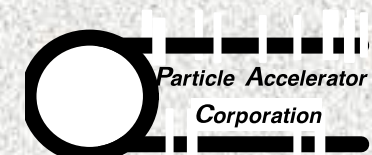



FFAG

Description of New Tools in COSY INFINITY for Fixed-field Accelerators

- Modern extensions of the transfer map-based philosophy as implemented in the arbitrary order code COSY INFINITY remedy the limitations in order and in the accuracy of the dynamics.
 - However, standard configurations based on pre-selected field elements like combined function magnets with edge angles, are not sufficient to describe in full detail the richness of the nonlinearities that can arise in the fields.
 - New tools which accurately describe complex fixed fields and edge configurations have been developed and tested in COSY INFINITY
- Equally important is the ability to perform extended design optimization, and move away from the current standard of local optimization based on starting conditions that are carefully chosen by educated guesses of the designer, and manually adjusted should the resulting local optimization fail.
 - Recent significant advances in global optimization as illustrated by the various different directions of cutting edge research including genetic optimization, domain and conquer approaches, and verified methods have led to a state of the art in optimization that need to be tapped into in order to simplify and improve the design and optimization procedures.
 - This and incorporation of a modern user interface to facilitate use of the code is in progress.





FFAG Example of dynamics studies of fixed-field accelerators using new tools in COSY

- Below is a sample FFAG having sixfold symmetry, with focusing stemming from an azimuthal field variation expressed as a single Fourier mode as well as edge focusing. The system is studied to various orders of out-of-plane expansion with the results for orders three and five shown below (typical of a conventional out-of-plane expansion in codes like Cyclops).

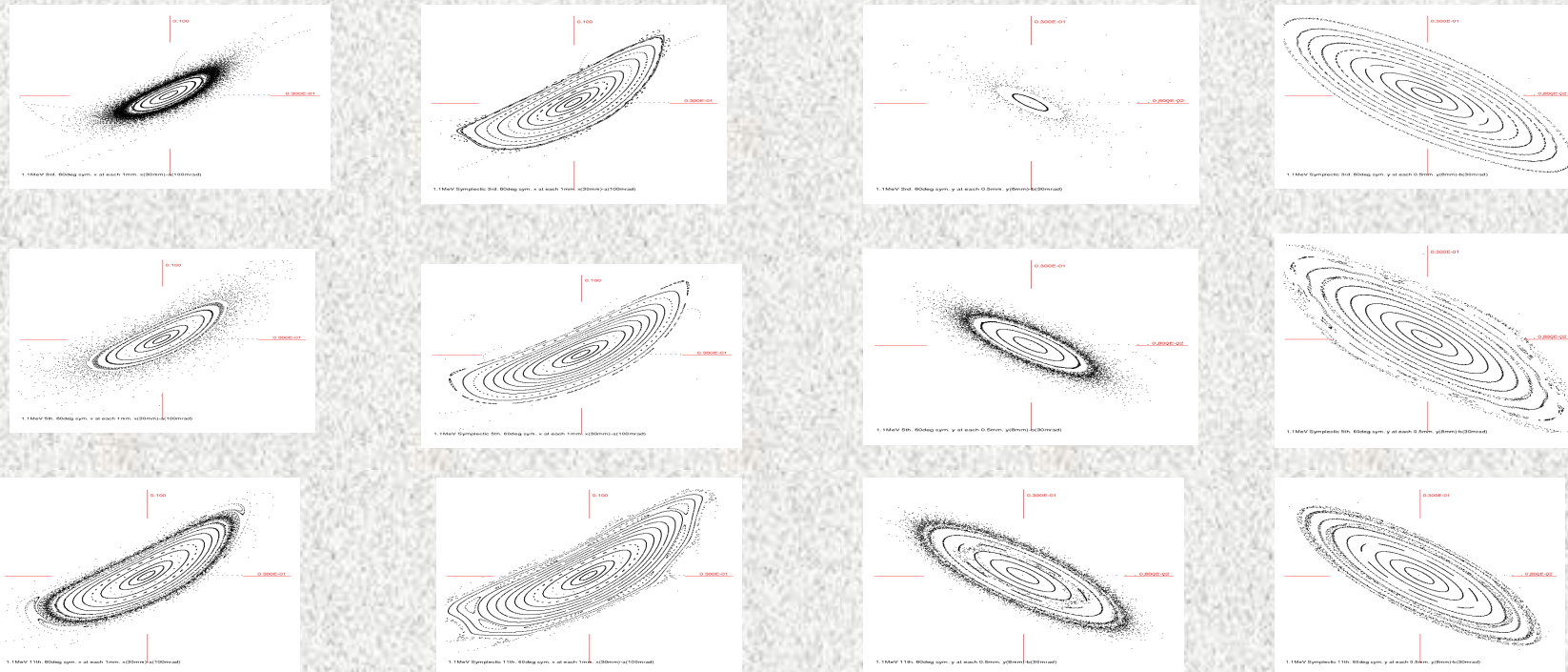

Tracking in a model non-scaling six-fold symmetric FFAG for horizontal (left pairs) and vertical (right, pairs) with 3rd (top), 5th (middle), and 11th (bottom) order out of plane expansion, with focusing from an azimuthal field variation expressed as a single Fourier mode as well as edge focusing. With (left) and without (right) Expo symplectification is shown.



FFAG

Advanced Modeling Simulations in COSY INFINITY

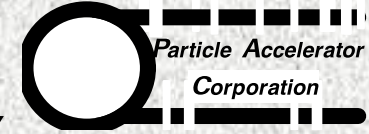

- As conventional accelerator codes provide too-little flexibility in field description and are limited to low order in the dynamics, new tools were developed for the study and analysis of FFAG dynamics based on transfer map techniques unique to the code COSY INFINITY.
- Arbitrary shapes, field content, contours
- Various methods of describing complex fields and components are now supported including representation in radius-dependent Fourier modes, complex magnet edge contours, as well as the capability to interject calculated or measured field data from a magnet design code or actual components.

HARD EDGE

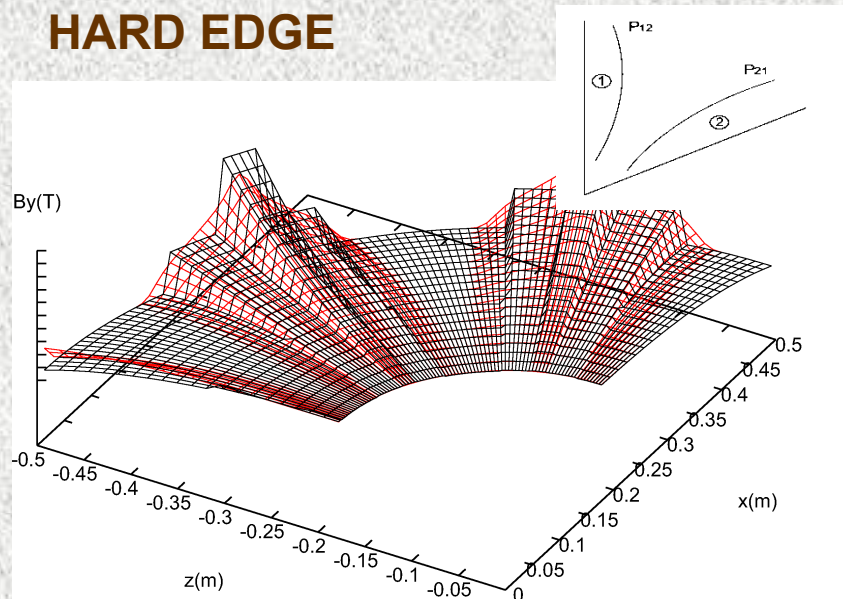

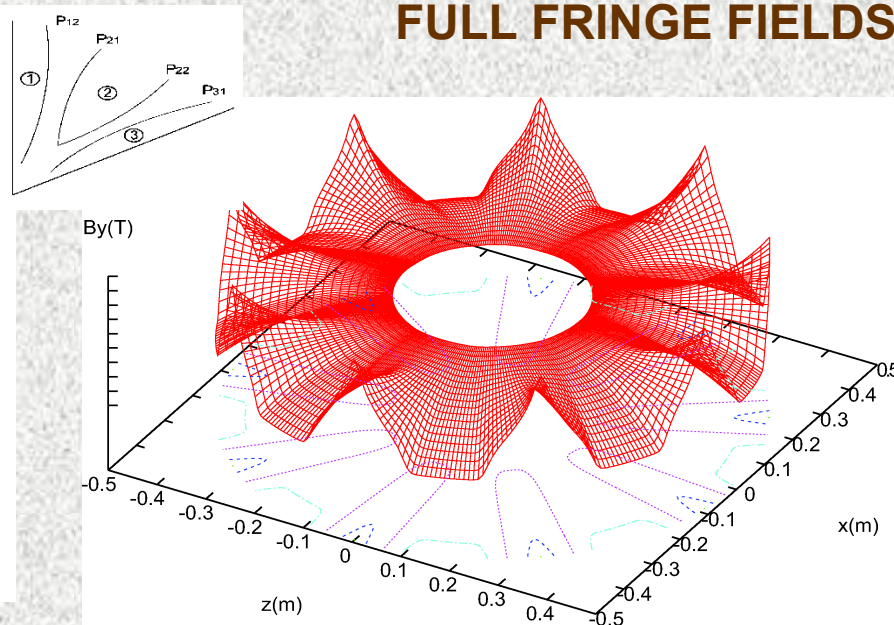

FULL FRINGE FIELDS





FFAG

Step-by-step design of FFAGs and Cyclotrons: more details

- For a starting design, equations of motion (without the angle or kinematical term in the Hamiltonian) are solved in terms of variables which describe the fields and physical parameters of the magnetic components;
- 
- Physical and technical requirements are automated directly into this initial design search and optimization such as field strength or footprint limits, component lengths, edge contours, and inter-magnet straights.
- 
- The output of the design parameter search is imported directly into COSY INFINITY for dynamics, and final optimization about this initial design point
 - COSY INFINITY also generates a realistic 3D field map (with contours and end fields) in polar coordinates from the initial design specifications which can be imported into field-tracking codes such as CYCLOPS and ZGOUBI

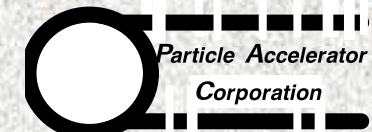



FFAG

Advanced design and simulation of an Isochronous 250-1000 MeV Nonscaling FFAG

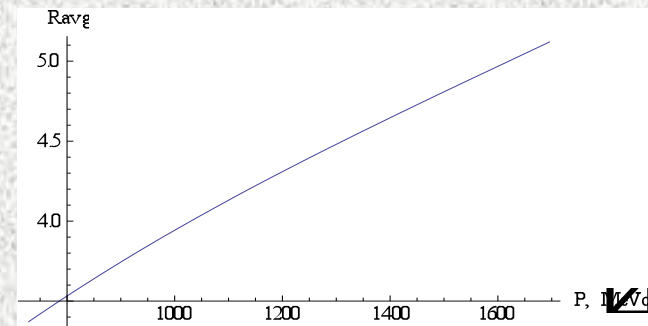
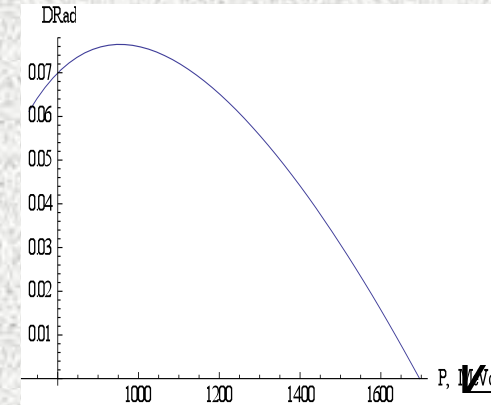
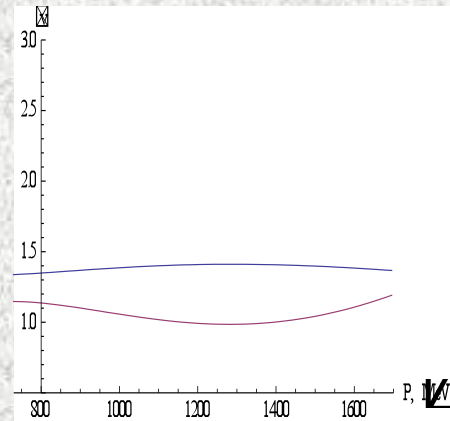
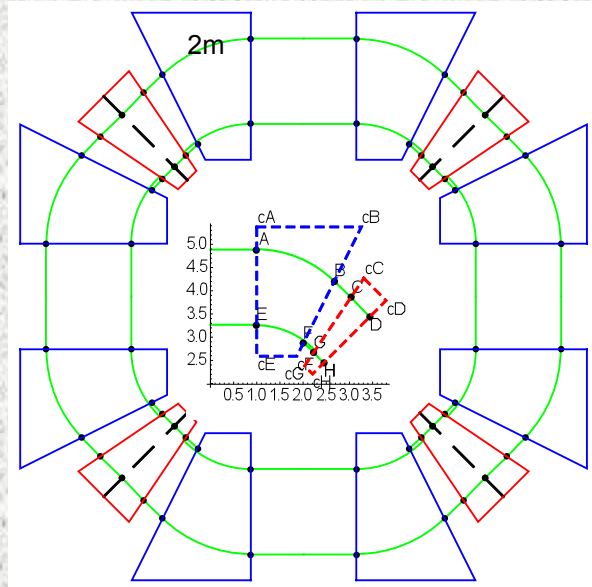

General Parameters of an initial 0. 250 – 1 GeV non-scaling, near-isochronous FFAG lattice design

Parameter	250 MeV	585 MeV	1000 MeV
Avg. Radius (m)	3.419	4.307	5.030
Cell ν_x / ν_y (2π rad)	0.380/0.237	0.400/0.149	0.383/0.242
Ring.	1.520/0.948	1.600/0.596	1.532/0.968
Field F/D (T)	1.62/-0.14	2.06/-0.31	2.35/-0.42
Magnet Size F/D Inj	1.17/0.38	1.59/0.79	1.94/1.14

Clockwise: *Matemtica*: Ring tune, deviation from isochronous orbit (%), and radius vs. momentum

- Comments and further work
 - Tracking results indicate $\sim 50-100\pi$ mm-mr; relatively insensitive to errors
 - Low losses

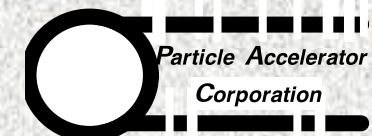



FFAG

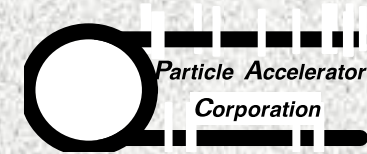

Field Map and Tracking: 250-1000 MeV Proton Driver

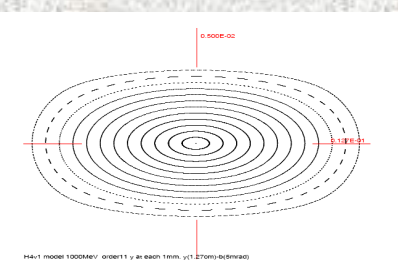
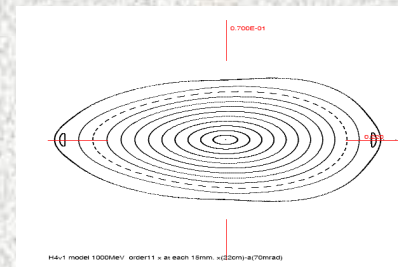
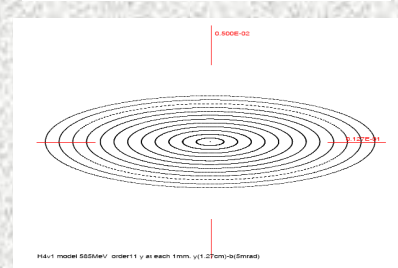
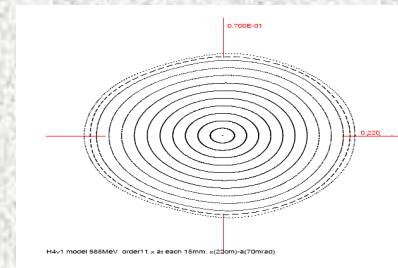
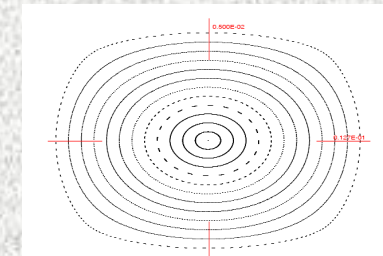
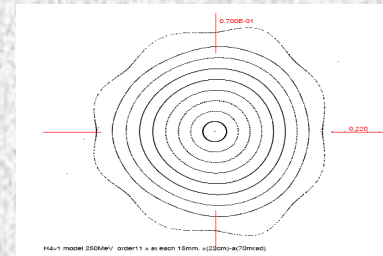
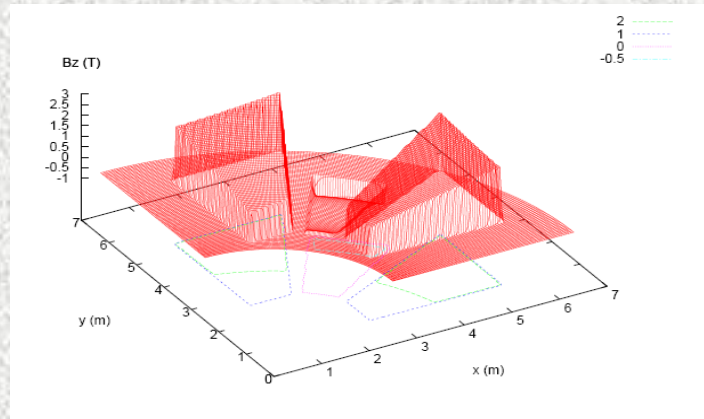

- Immediate large DA aperture:
 - 50-100 mm-mr without correction
 - 0.1-1% error tolerance –typical magnet tolerances
- Final isochronous optimization will be performed using advanced optimizers in COSY

Dynamic aperture at 250, 585, and 1000 MeV – step size is 15 mm in the horizontal (left) and 1 mm in the vertical (right).



FFAG

1-GeV Proton Driver Modeled in CYCLOPS: fine mesh and fringe fields (Y.N Ray and M. Craddock, TRIUMF)

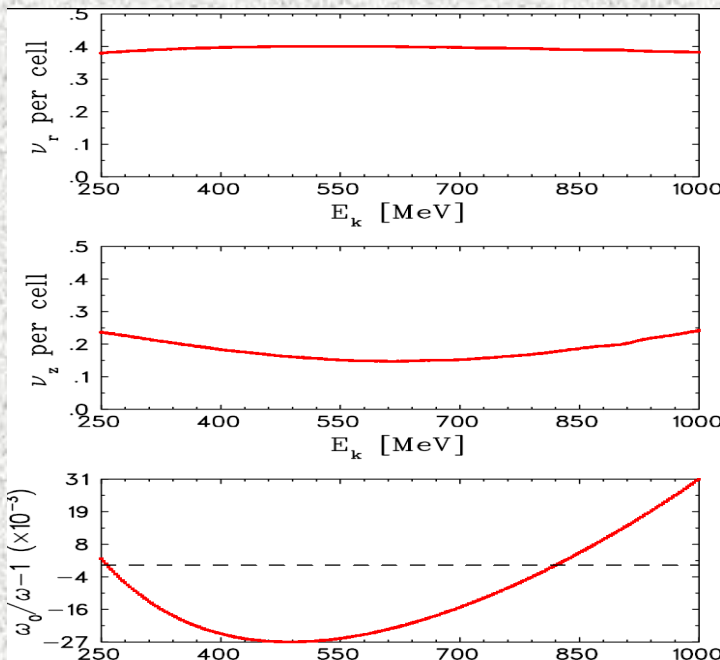
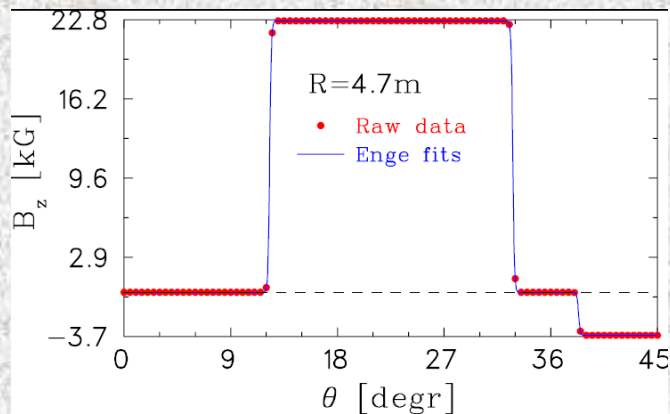

- B field with Enge function fall off
- tune per cell (radial, horizontal)
- tune/cell (z, vertical)
- frequency change, isochronous to +/- 3% using simple hard-edge model: progress will require the advanced codes; agrees with COSY results



FFAG

Application: Accelerator-Driven Subcritical Reactor

- Advantages

- Injection through a lower-energy H^- ring or 250-MeV H^- linac
 - CW operation for high power output
 - Compact footprint (especially compared to a 1 GeV linac)
- The simplicity of fixed-frequency rf system
 - Swept-frequency rf is required for a synchrotron or synchro-cyclotron
 - Isochronous cyclotron is large machine
- Low losses
 - With strong focusing losses are comparable to a synchrotron
 - Critical for successful high-intensity operation (10 MW)
- Strong focusing – strong vertical tunes
 - Mitigate impact of space charge
 - Promote increased stability at high intensities

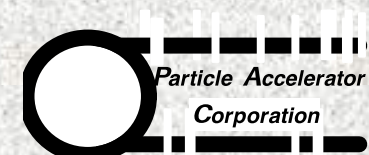



FFAG

Example: lower-energy isochronous FFAG – preliminary 150-250 MeV SC Proton Ring

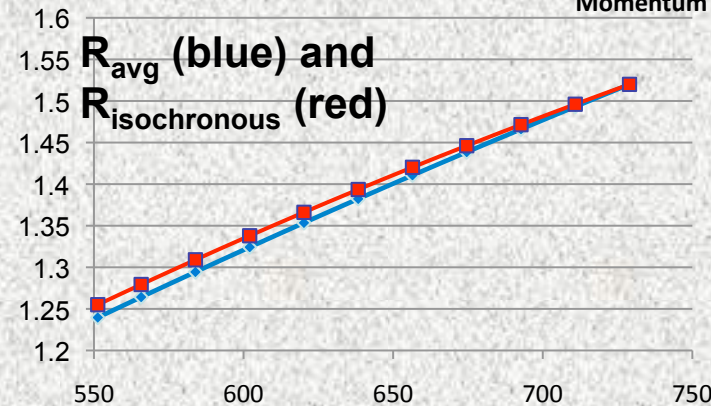
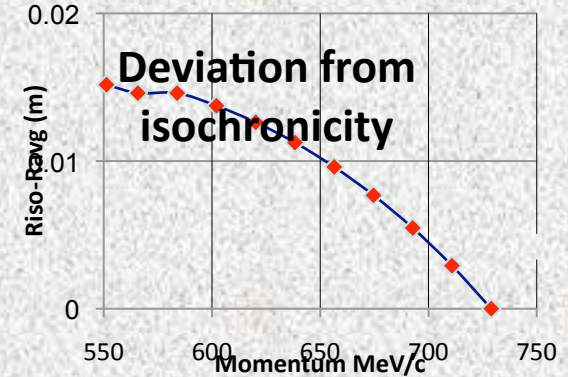
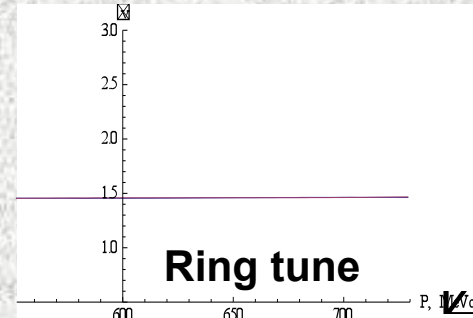
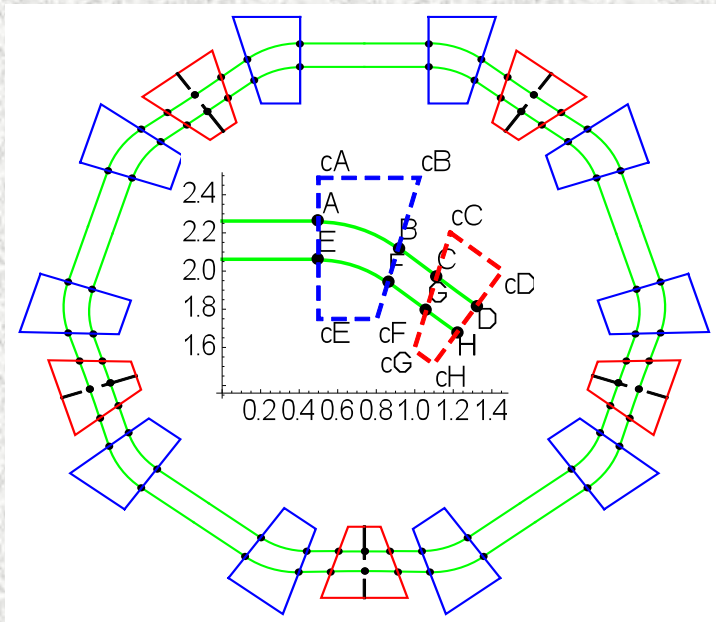

- Comments

- Peak field 3.5T @extraction in F;
- small 25 cm aperture
- Low losses

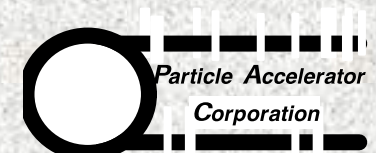



FFAG

Application: One stage in a Medical Therapy Accelerator

- Advantages
 - Near-relativistic energies and for a FFAG
 - Implies reduced component apertures
 - Reduced cost for SC components
 - SC implies smaller footprint
 - Supports CW acceleration
 - Multiple straights
 - Supports multiple rf systems
 - Therefore multi-ion acceleration (not necessarily isochronous or CW)
- Lower-field version could serve as an upstream accelerator for ADS by accelerating H^-

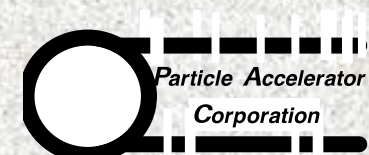



FFAG

Dual Accelerator Patient Model

Below is a model-based treatment using 70 MeV as a lower limit since many nozzles (or energy degraders) only work in the 70 to 250 MeV range. (Lower energies can be obtained by plastic range shifters placed close to the skin and aperture, for example with breast, pediatric patients, and parotid tumors in the jaw.)

- Site Percentage Energy Range (MeV)
- Lung 9% 70 - 170
- Breast 3% 70 - 140
- CNS 15% 70 - 150 (central nervous system, i.e., base of skull & tumors around spinal vertebrae)
- Rectum 2% 70- 170 (also cervical cancers may be a few % in this energy range)
- Pediatric 8% 70 - 150
- Head &
Neck 15% 70 - 150
- Prostate 45% 200-250
- Other 2%

This fits nicely with a dual energy accelerator system where $E \leq 150$ MeV can be used for roughly 50% of the patients. At PSI all patients were treated with $E < 180$ MeV excluding prostates. Raising the energy to 170 would not be difficult and make the SC outer ring aperture and operation even more efficient.



FFAG

Preliminary Isochronous 18-150 MeV H- NS FFAG

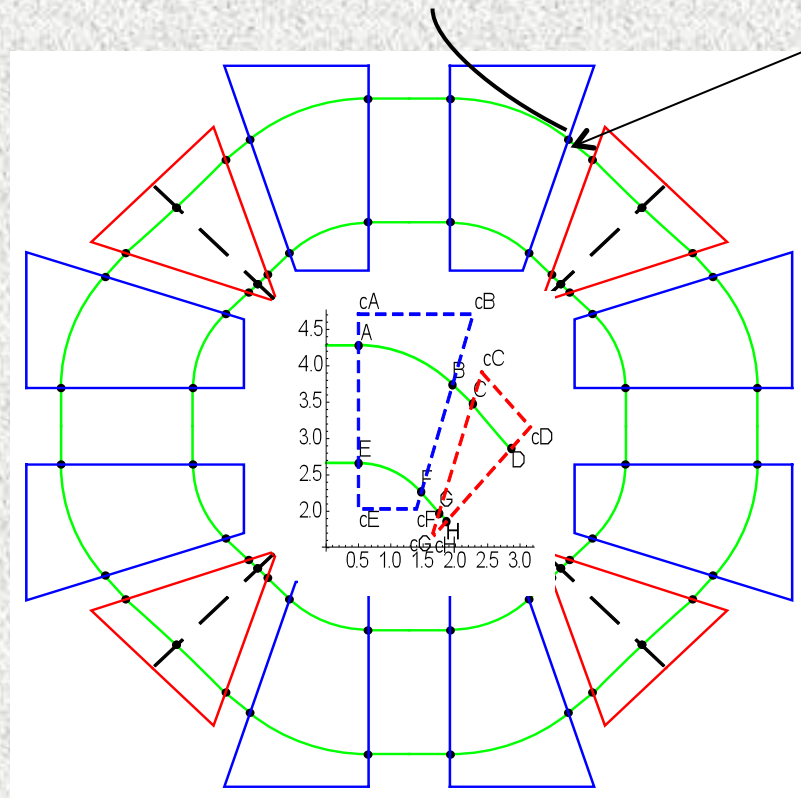

Stripping wire H- → proton

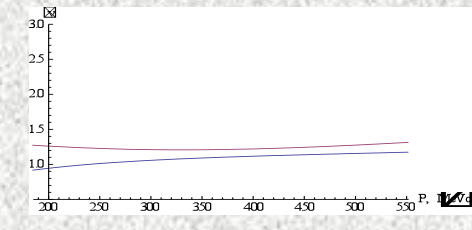
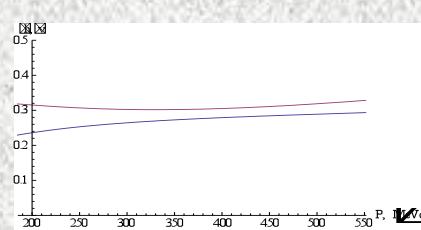

Tune per cell and ring tune. Extended fringe field will split tunes

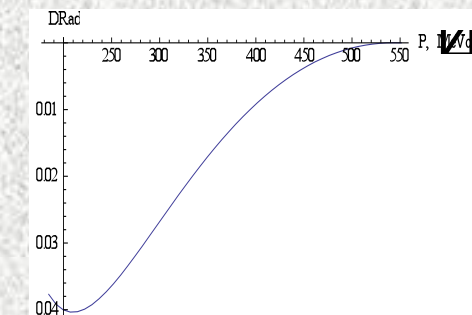
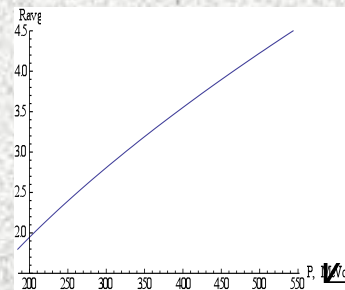

Average radius vs momentum and deviation in % from isochronous average radius

- Comments and further work
 - Peak field 0.8T @extraction in F can take this design to 180 MeV
 - Increase compactness: 3-sector or no reverse bends, low losses – reduced shielding



FFAG "PAMELA" Machine for Hadron Therapy: 30-250 MeV Proton FFAG (non-isochronous)

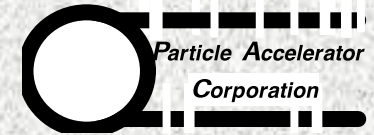

initial lattice parameters compared with full field description and model in **COSY INFINITY**

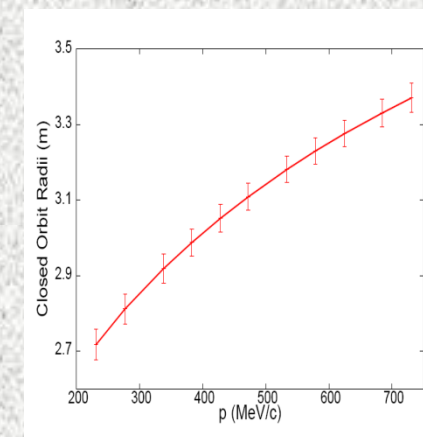
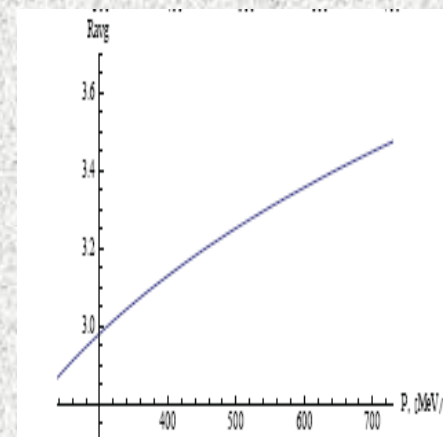
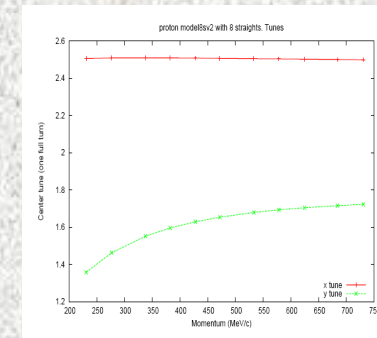
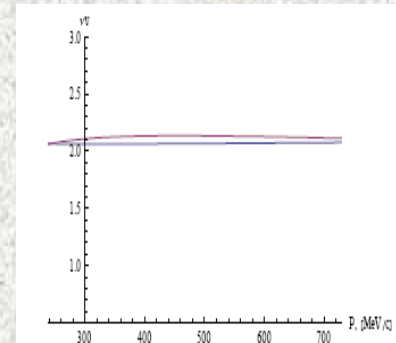
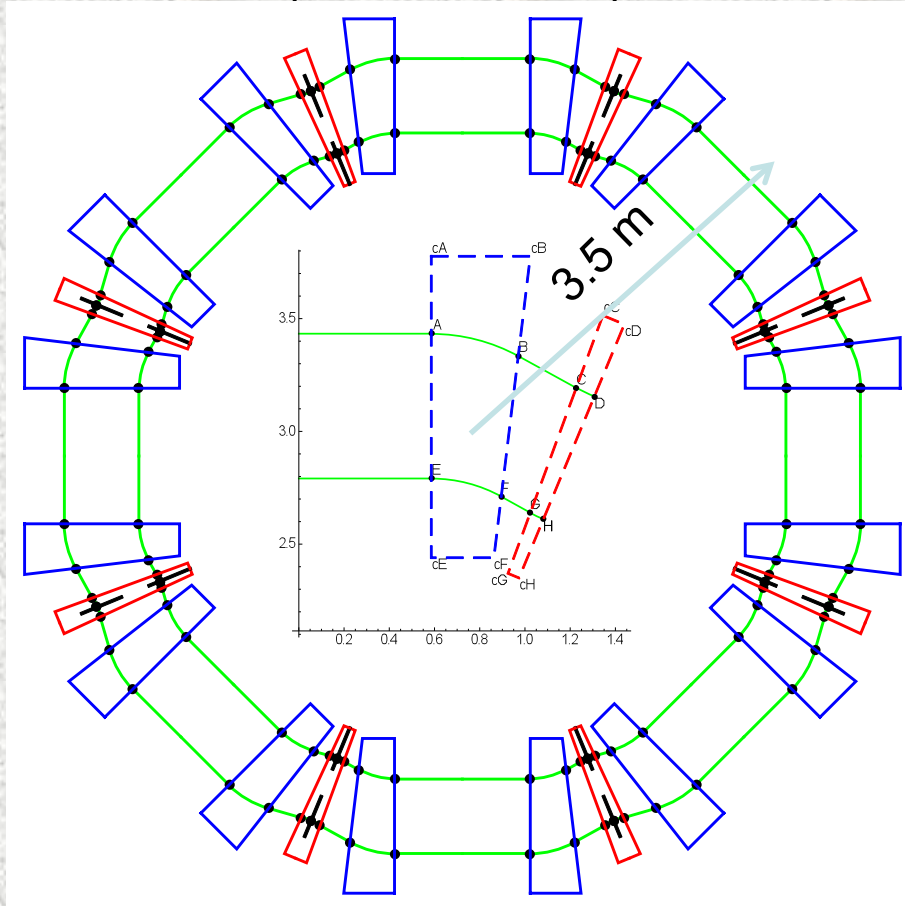

Strong tune splitting horz/vert due to actual extent of fringe field, but radial dependence (i.e. avg field) is well reproduced



FFAG

COSY INFINITY results and DA

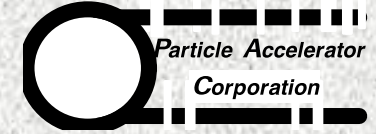

General Parameters of the triplet 30-250 MeV nonscaling FFAG design.

General Parameters of the triplet 30-250 MeV nonscaling FFAG design after tune optimization in COSY – only tune variations are affected.

Parameter	Unit	Injection	Extraction
Energy Range	MeV	30	250
Tune/cell (ν_x / ν_y)	2π -rad	0.31 / 0.16	0.31 / 0.21
Ring tune (ν_x / ν_y)		2.51/1.28	2.51/1.66
Average Radius	m	2.75	3.39
No. cells		8	
Long Straight	m	1.17	1.17
Peak Field	T		
F		1.21	3.13
D		-1.37	-3.41
Magnet Lengths	m		
F		0.646	0.803
D		0.129	0.176
Apertures	m		
F		0.63	
D		0.55	

Parameter	Unit	Injection	Extraction
Energy Range	MeV	30	250
Tune/cell (ν_x / ν_y)	2π -rad	0.31 / 0.22	0.31 / 0.19
Ring tune (ν_x / ν_y)		2.48/1.75	2.48/1.55
Average Radius	m	2.75	3.39
No. cells		8	
Long Straight	m	1.17	1.17
Peak Field	T		
F		1.21	3.13
D		-1.37	-3.41
Magnet Lengths	m		
F		0.646	0.803
D		0.129	0.176
Apertures	m		
F		0.63	
D		0.55	

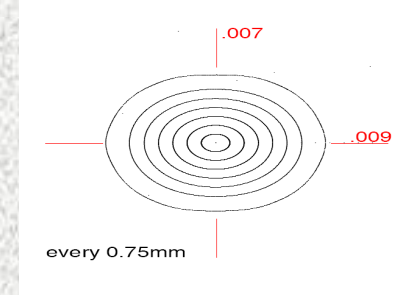
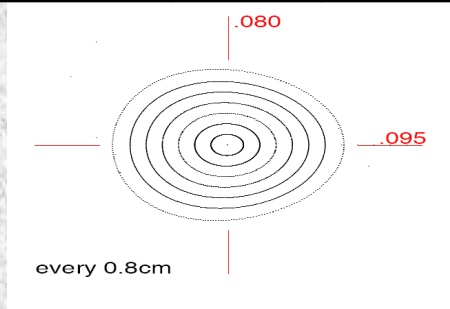

Dynamic aperture a midpoint, 112 MeV., horizontal (left), vertical (right) DA at all energies for both planes is extremely large.



FFAG

Application: Proton Therapy

- Advantages:
 - Variable energy – no degrader
 - Resonant or kicker-based extraction
 - Gate to respiration, for example
 - Long straight for low loss extraction
 - Multiple long straights
 - Supports multiple rf systems
 - Therefore multi-ion acceleration
 - Final ring for proton, but booster ring for carbon
 - Nest rings
 - Compact total footprint: as in KURRI facility

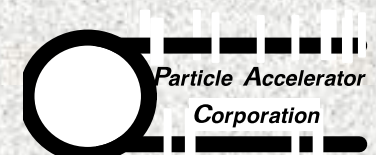



FFAG

Example: Nested FFAG rings for proton/carbon therapy



- Inner ring up to 250-MeV protons for therapy and serves as booster ring for heavier ions (carbon)
- Dual rf system for p+C in inner ring
- Outer ring supports 400 MeV/ μ carbon with longer (2m) straights
- Embedded rings for multi-ion cancer therapy make a compact accelerator chain

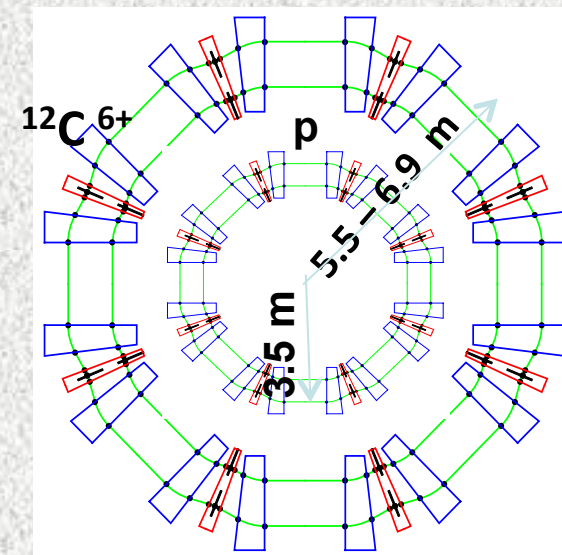
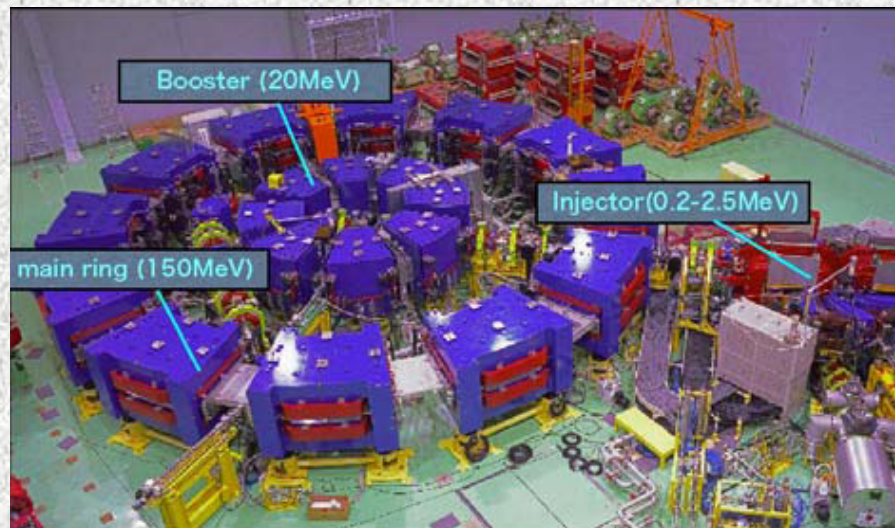



FFAG

Comparison of a sector cyclotron with a FFAG using advanced design and simulation tools

- Study of a low-energy cyclotron vs. FFAG equivalent designs:
 - 5 kG field at injection;
(For cyclotron implies a 5 kG field at all energies.)
 - 1T limit on the extraction field in the FFAG
 - ≥ 10 cm magnet @injection (to achieve 5 kG)
 - ≤ 5 cm between magnets at injection.
 - Same footprint: an ~ 0.9 m radius
 - No reverse bends in the FFAG
 - vertical focusing is through edge crossing.
 - 4 sectors both designs

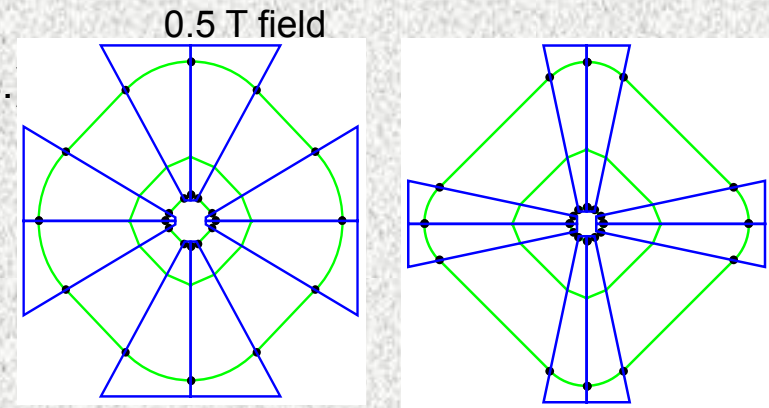

Low-energy cyclotron (left) and equivalent FFAG (right)

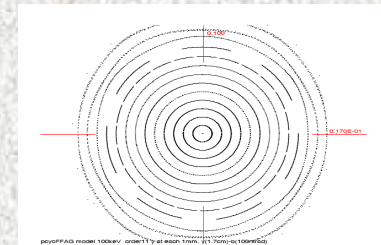
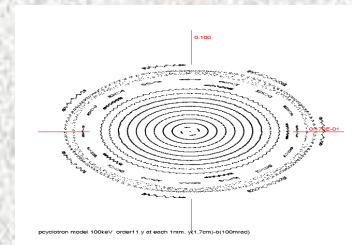
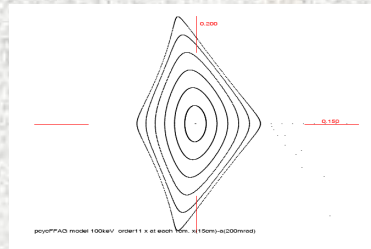
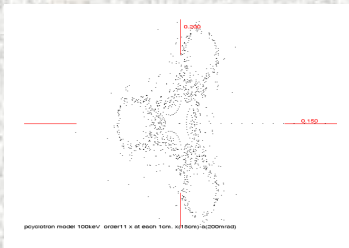

Subtleties in transverse dynamics of cyclotron and FFAG at 100 keV:
Horizontal cyclotron and FFAG (left pair) and vertical cyclotron and FFAG (right pair) as observed in advanced simulations



Example: 50 keV to 9 MeV Compact Electron Accelerator

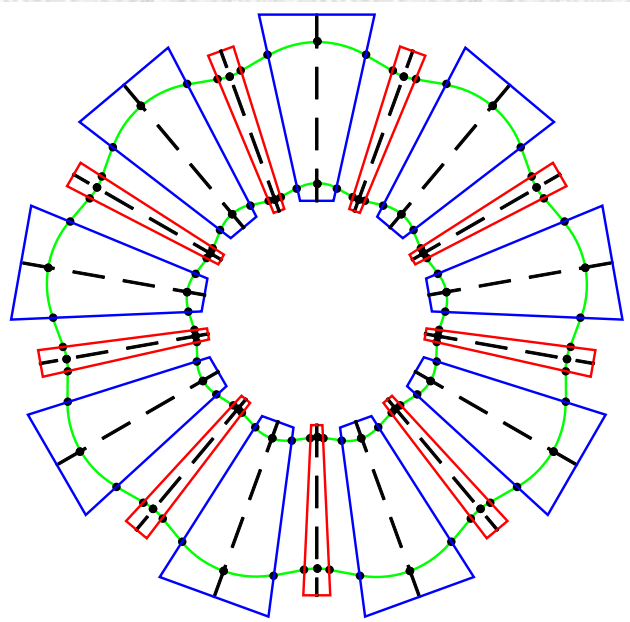

Mathematica® Full 9-MeV ring with injection and extraction orbits displayed.

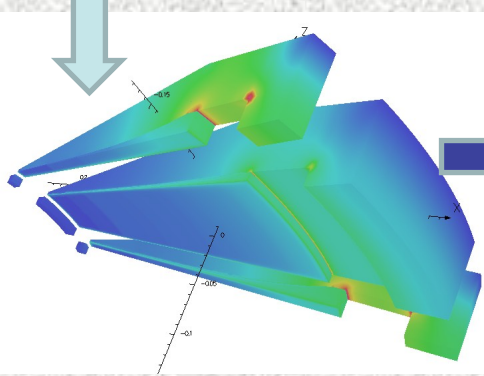

TOSCA Magnet Design and Field profiles.

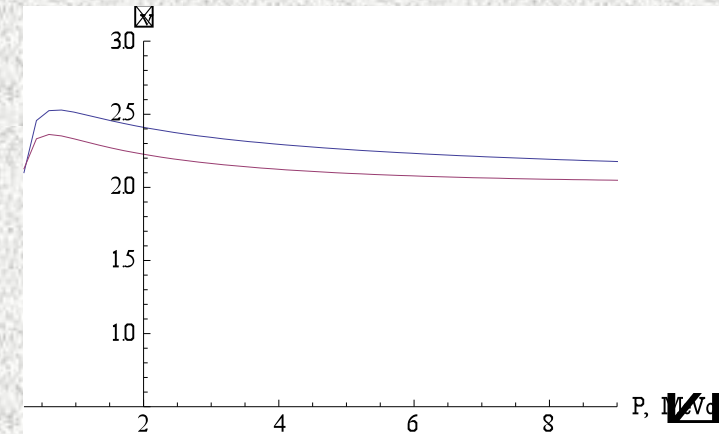
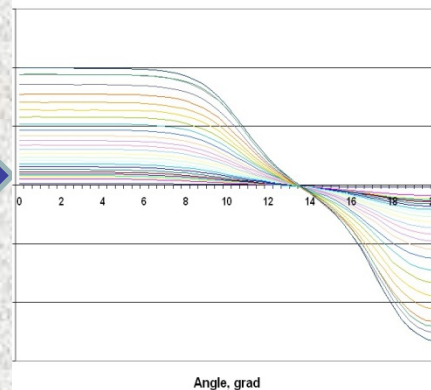

COMPARISON Tune Results:
hard edge vs. extended fringe field

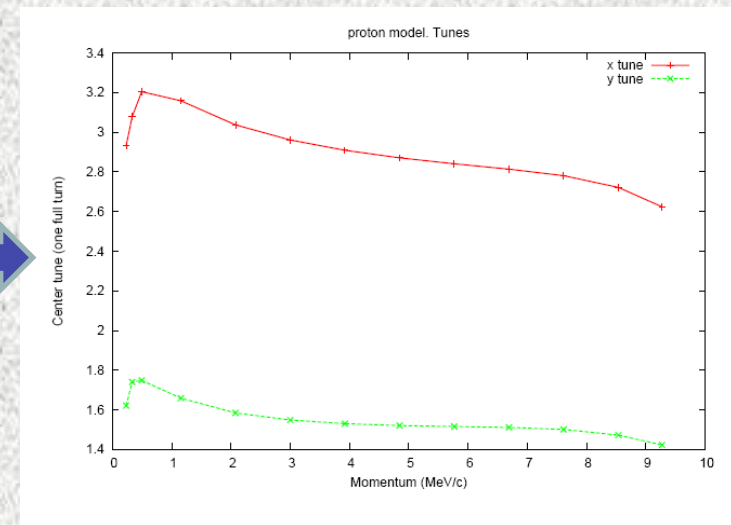

COSY INFINITY Tune Results



FFAG

COSY Results: Electron Ring

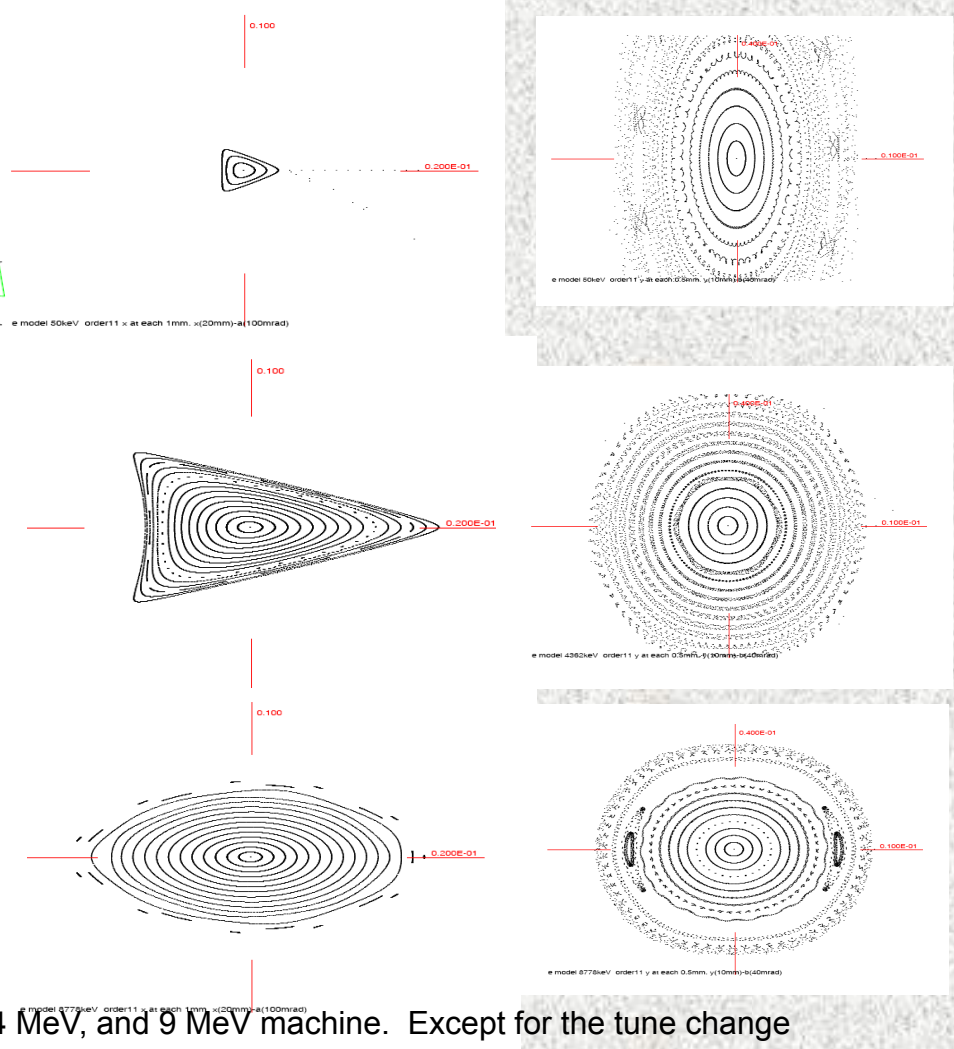
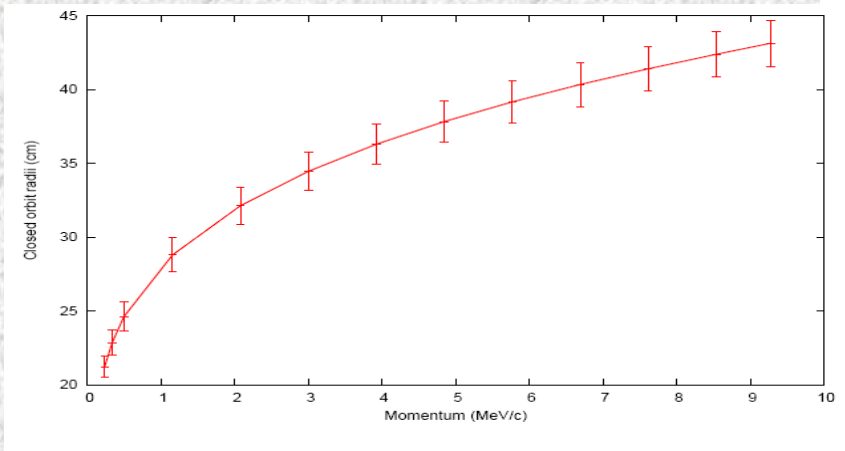
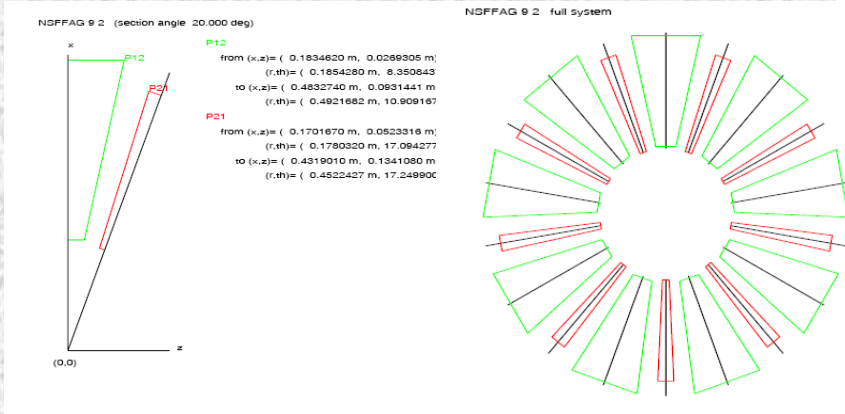

COSY results and tracking at 3 energies: 50 keV, 4.4 MeV, and 9 MeV machine. Except for the tune change required at horizontal injection, the DA is very large.



FFAG

General Comparative Comments

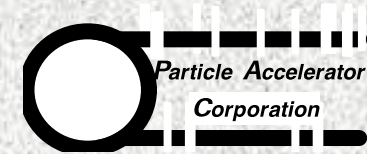

- Synchrotron duty cycle and beam control has improved significantly, however
 - Expert staff
 - Complex, expensive subsystems (swept-frequency rf and ramped magnets)
 - These factors tend to make them less attractive for many medical and commercial applications
- Cyclotron for many applications provide continuous beams
 - Single operator, simpler system to operate
 - Compactness leads to higher losses: proximity of high-energy orbits: little insertion space for a septum
 - Significant shielding required for the machine itself, energy degrading, collimation and energy selection: advantage in footprint is not as significant considering shielding requirements
- FFAG
 - No pulsed operation – simple operation like the cyclotron, can be CW
 - Synchrotron-like focusing and straights promote lower losses



FEAG

Summary of advantages based on advances in FFAG technology

- CW operation (into relativistic energies) with new isochronous lattices
 - Simplicity and lower cost of fixed-frequency rf
- Strong focusing in a fixed field accelerator has demonstrated
 - Large, stable dynamical acceptance
 - Lower losses, particularly with smaller beam envelopes in vertical
 - Support of multiple long straights
 - Lowered extraction losses
 - Mitigation of space charge effects (strong tune in vertical), higher bunch intensities
 - Resonant and kicker-based extraction (horizontal and vertical)
 - Variable energy without use or reduced use of a degrader
 - Improved beam transmission at low energies
 - Respiration gating can be kicker based
 - Reduced shielding requirements – reduced civil costs
- Nested Rings
 - Compact footprint even for a multi-ion facility

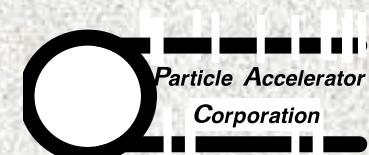



FFAG

Concluding Remarks

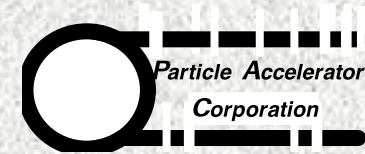

- FFAG designs are advancing rapidly internationally, particularly for medical and high-energy applications with an isochronous nonscaling FFAG now designed and verified
- The first demonstration of Accelerator Driven Subcritical Reactor was performed this year at KURRI using the FFAG.
- Embedded rings supporting a compact multi-ion therapy facility are an exciting new direction for FFAGs.
- Highly advanced design and simulation tools have been developed and tested for FFAGs and cyclotrons and are ready for public distribution

