

H- charge exchange injection into the 150 MeV FFAG

Kota Okabe (Fukui University)

Basic parameters for ADSR experiments at KURRI (1st stage)

- Reactor output power $\sim 10\text{W}$
- Neutron multiplication $< 100(\text{max.})$
- Beam power of FFAG $< 0.1\text{W}$
- Beam energy of FFAG $100 - 150\text{MeV}$
- Beam current of FFAG $< 1\text{nA}$

FFAG-Main Ring

Charge-exchange Injection System (2nd stage)

MR beam intensity upgrade $\sim 1 \mu\text{A}_o$

- Charge-exchange Injection method
- New Injection
 - FFAG-ERIT H-Linac(11 MeV) (used for FFAG-ERIT)
- Space charge limit
 - Main Ring $\sim 1 \times 10^{12}$ ppp ($6.3 \mu\text{A}@30\text{Hz}$)
- Research for Accelerator Physics (Space charge effects)

Layout of Accelerator in Innovation Laboratory

2009/09/17

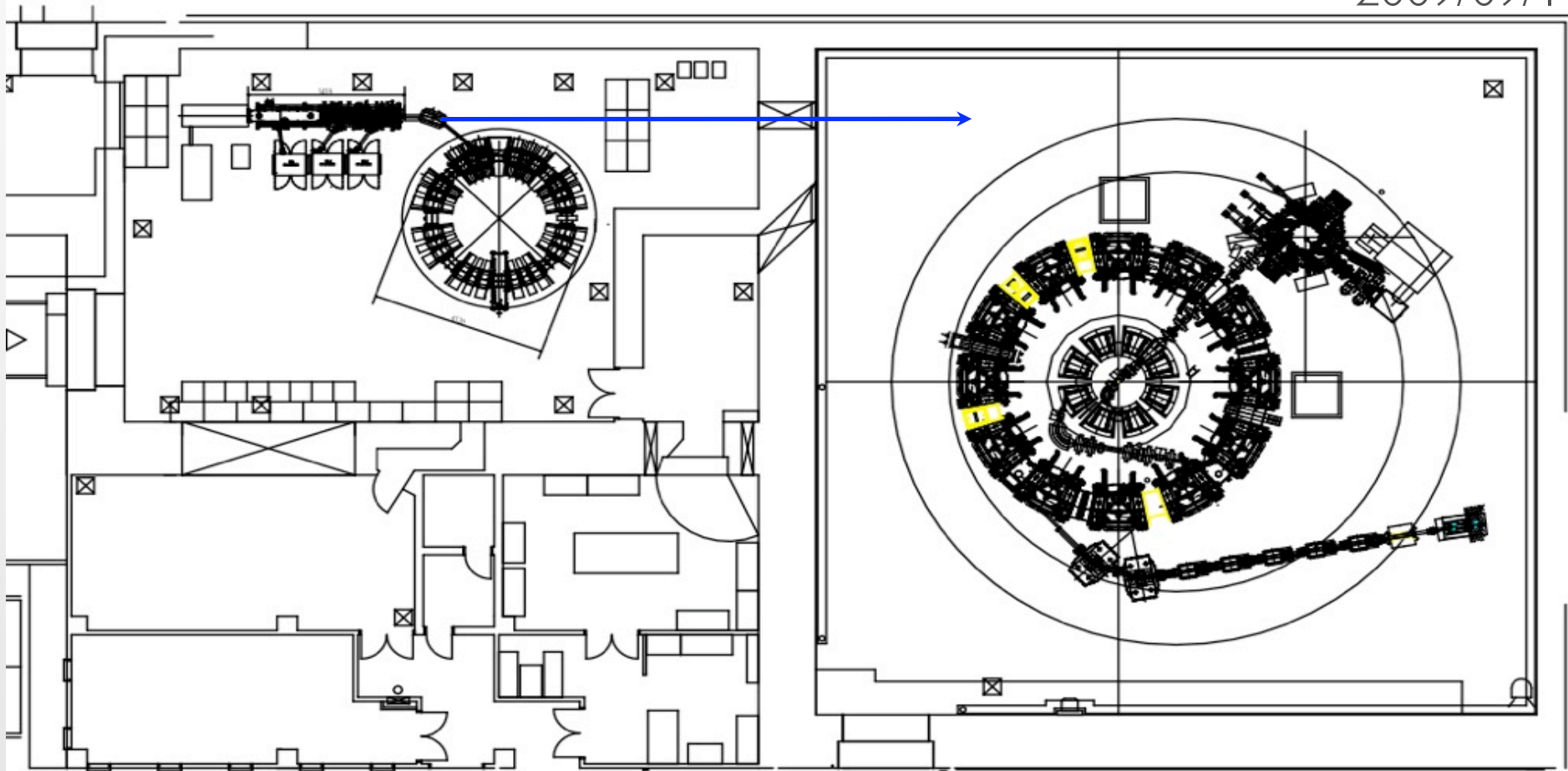

Contents (H⁻ Injection for the FFAG in KURRI)

- New injector system (H⁻ ion source, Linac)
- Beam transport line for beam injection
- Charge exchange injection for the FFAG-MainRing
 - Low energy H⁻ injection system
 - Stripping foil
 - Injection scheme
 - Energy loss and emittance growth
 - Off-center injection
 - How to escape the stripping foil after injection
- Beam study
- Some improvement of injection system
- Summary

New injector
(H⁻ ion source, Linac)

Spec of Linac + H⁻ Ion Source

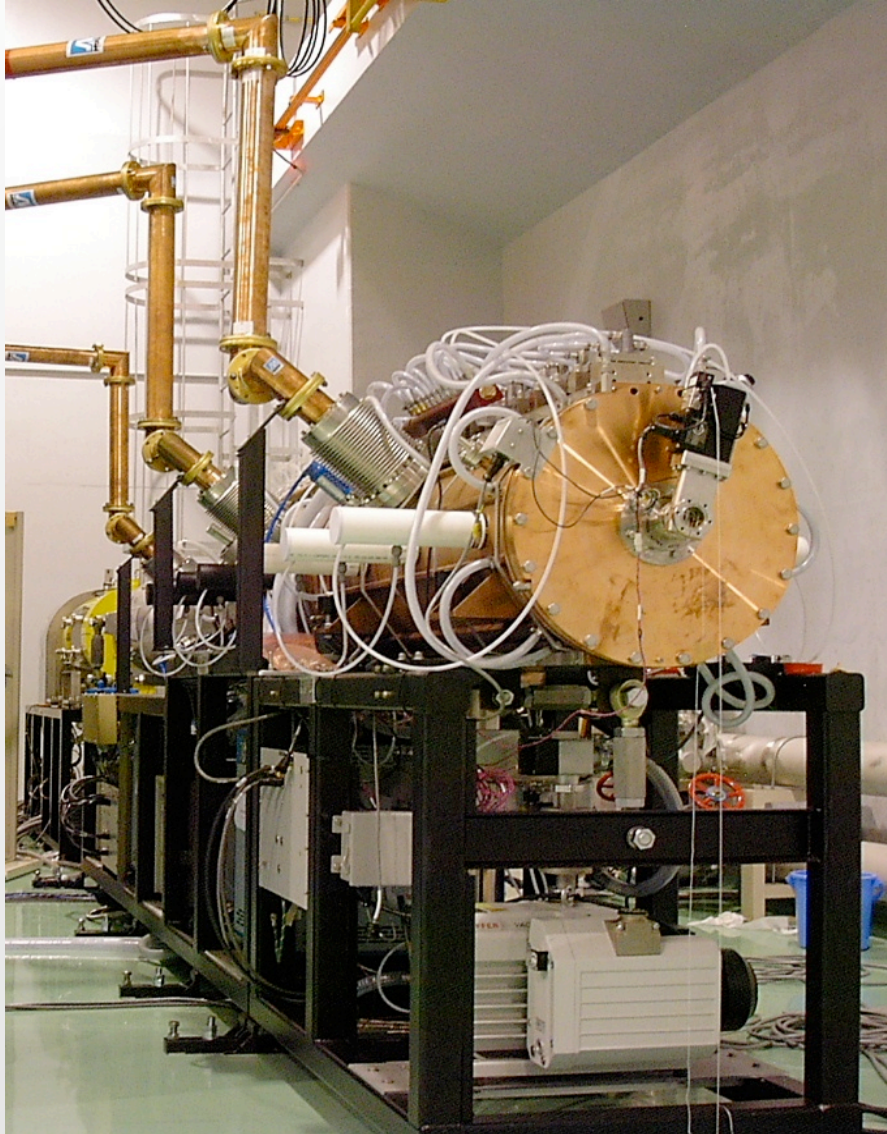

Linac beam parameter

Ion : H⁻

E_{ext} : 11 MeV

Beam Pulse width(MAX) : 100 μsec

Peak Curr.(MAX) : ~5 mA

: ~3.12 * 10¹² [ppp]

(Present injector) : ~6.00 * 10⁸ [ppp]

rep. rate : 1 Hz ~ 200 Hz

Horizontal

norm. emittance (90%) : 0.680 mm • mrad

Vertical

norm. emittance (90%) : 0.630 mm mrad

Ene. 90% : ΔE ~ 45 KeV

H⁻ Ion Source

- Particle : negative hydrogen
- Ext. energy : 30 keV
- max rep. rate: 200Hz
- beam duration: >4%(300 μ A)
- beam current:
 - >100 μ A (ave.)
 - ~5mA (peak)
- nor. emittance: < 1 π mm-mrad
- with chopper (~1.6MHz)

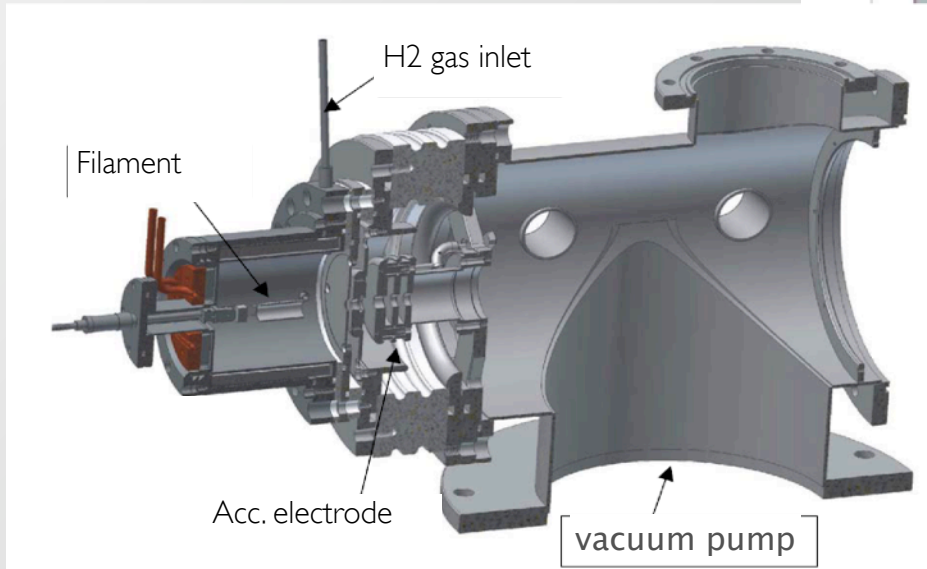
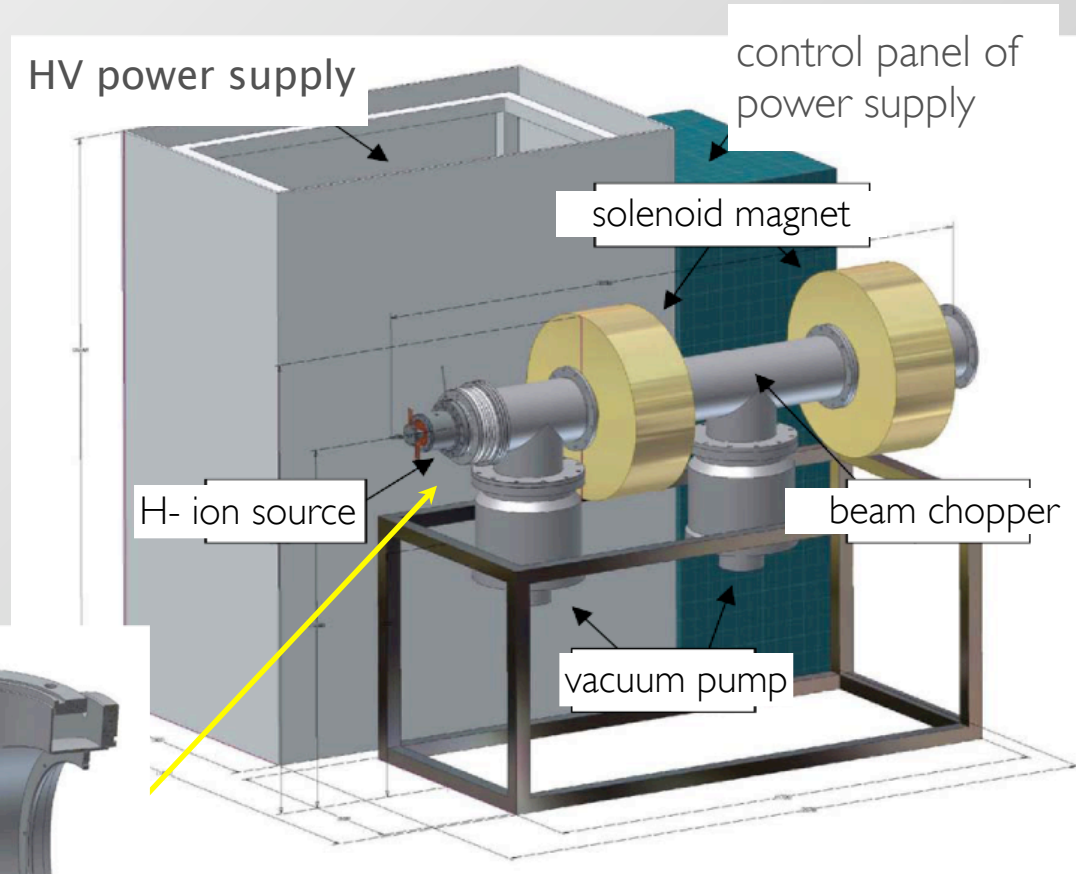

Injection Linac

- Beam energy 11 MeV
- Configuration of Linac
 - RFQ(3.5MeV)
 - DTL1(7MeV)
 - DTL2(11MeV)
- Length 5.3m
- Frequency 425MHz

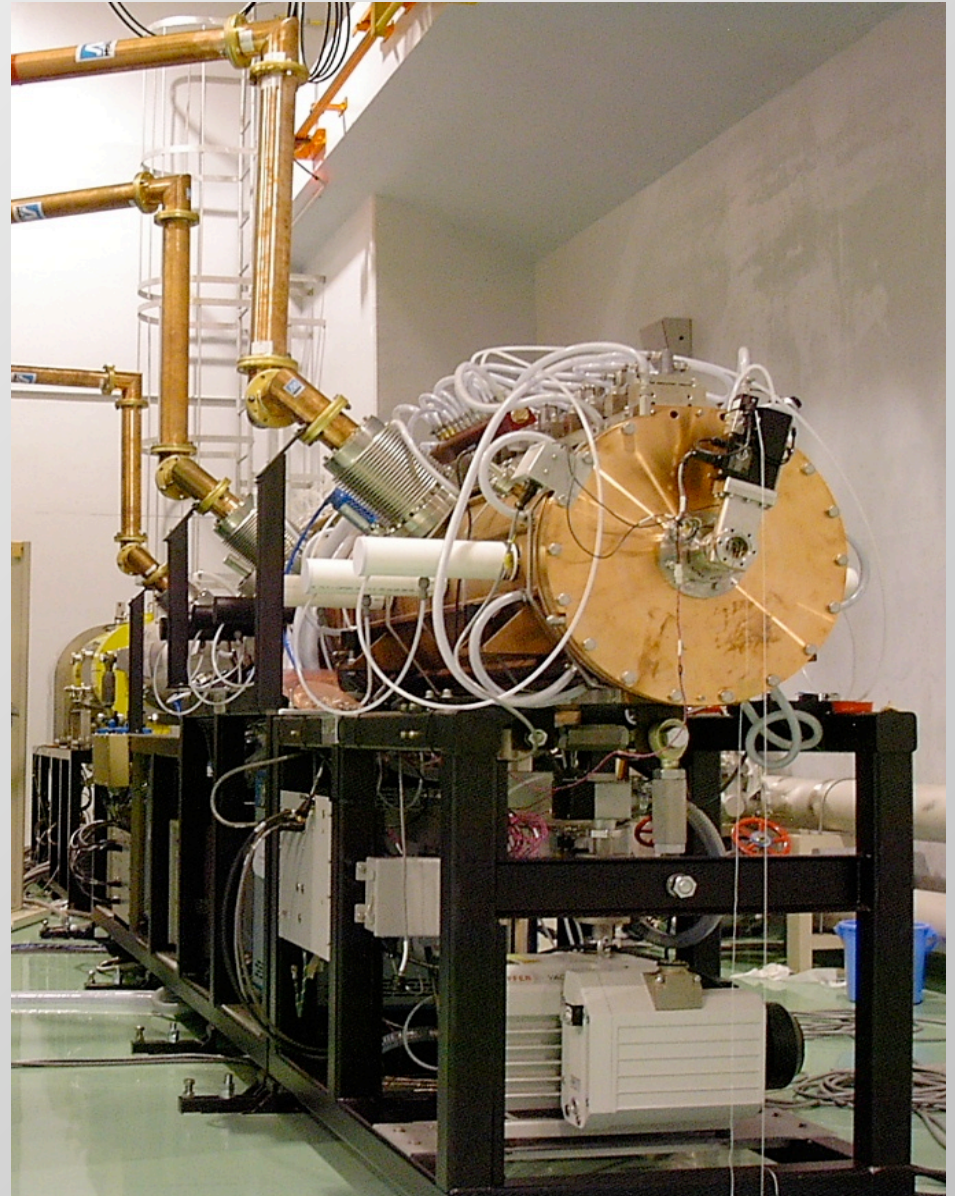

Space Charge Limit(Main-Ring)

Laslett tune shift (direct space charge)

$$\Delta\nu_{y,inc} = -\frac{Nr_0}{\pi\beta^2\gamma^3} \frac{F/B}{\epsilon_y(1 + \sqrt{\epsilon_x/\epsilon_y})}$$

$$\Delta\nu_{y,inc} < 0.3$$

$$N \sim 0.65 \times 10^{12} \text{ ppp} \quad (6.2 \mu\text{A for } 30\text{Hz})$$

r_0	$1.53 \times 10^{-18} \text{ m}$	classical radius of proton
R_0	4.54 m	mean radius
β, γ	0.158, 1.013	12MeV
(ϵ_x, ϵ_y)	(200,100) $\pi\text{mm-mrad}$	emittance
B_f	0.5	
F	1.5	

Injection Beam Line

H⁻ injection orbit

Beam merging of H⁻ and H⁺ beam will be performed by main magnets of FFAG. Injected beams will be merged to circulating beam without any injection septum magnet. There is no pulse device on injection orbit.

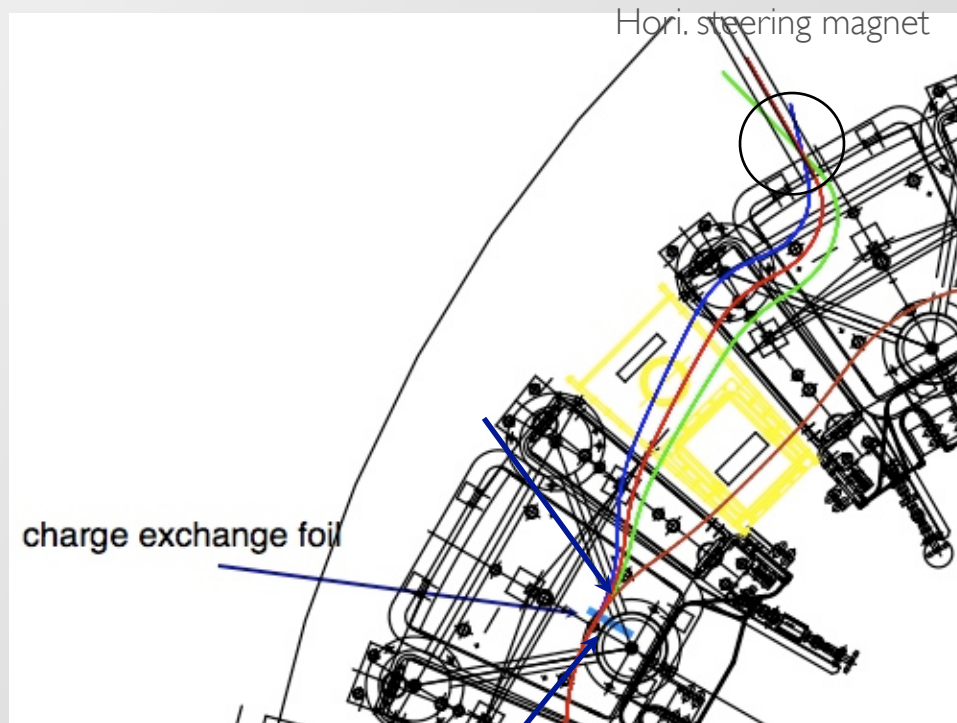

foil: 0.5deg upstream from the center of F magnet (red line)

H- beam-line(magnets)

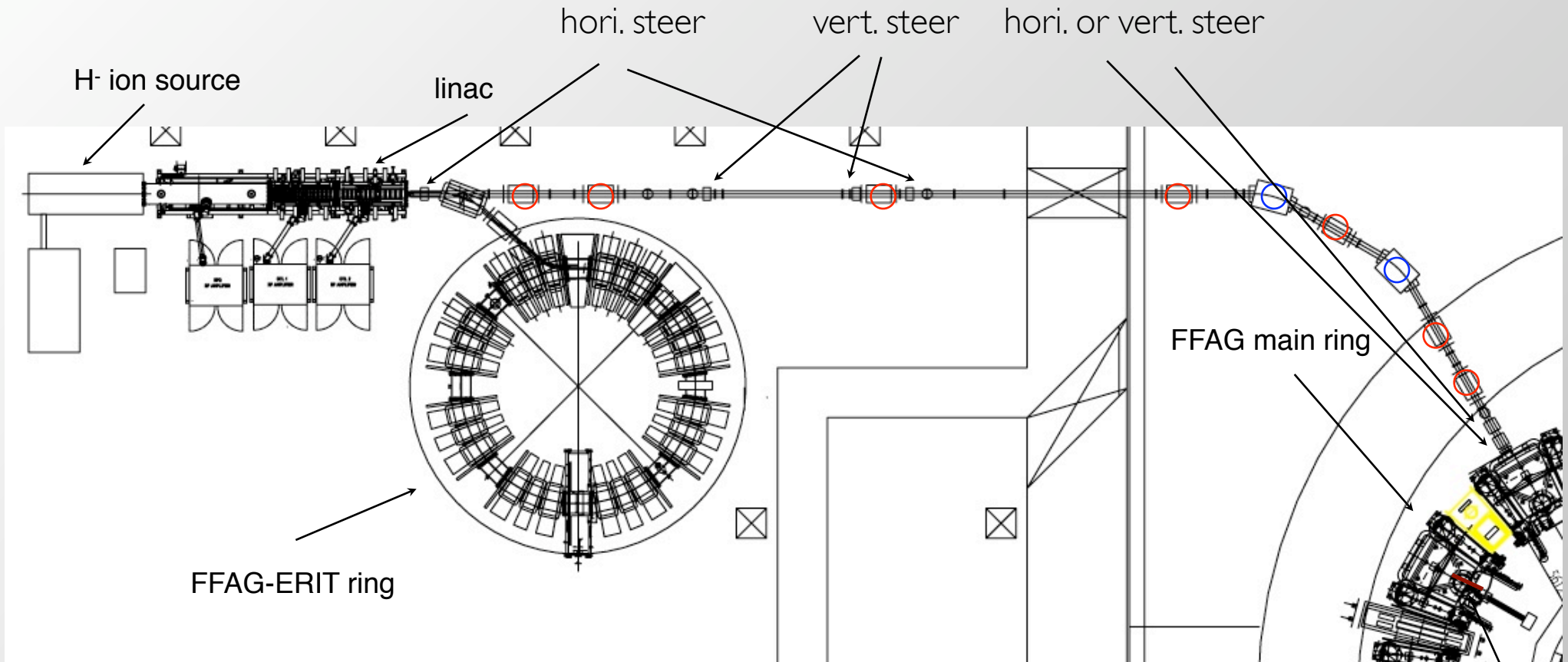

Q Magnet $\times 7$, B Magnet(30deg) $\times 2$

2011/07~ we have slightly changed this beam line.

charge exchange foil

Beam optics

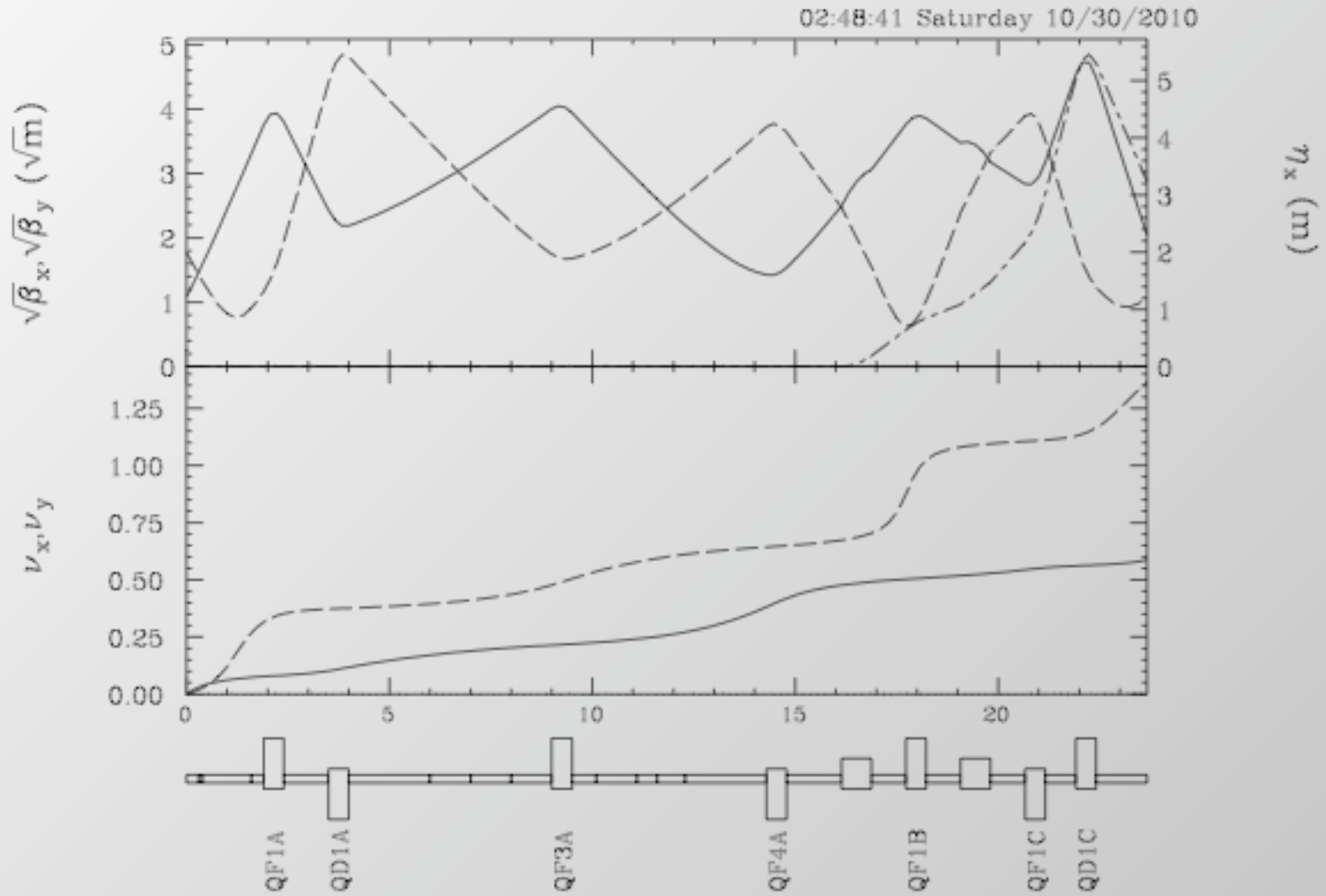

Construction of beam line

Construction of new beam line is completed.

Beam commissioning of H- injection and acceleration start from late November.

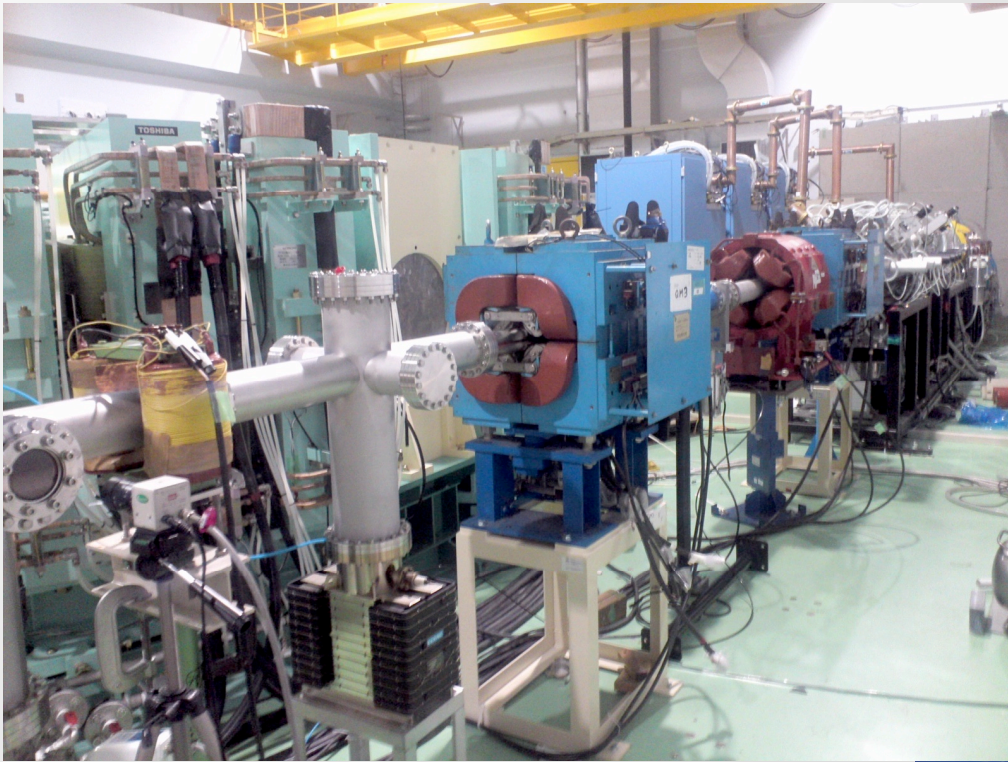

2010 September ~ middle of November

Charge-Exchange Injection for the 150MeV-FFAG

Charge-Exchange Injection Method

- Thickness of carbon stripping foils is about $10\sim 20 \mu\text{g}/\text{cm}^2$
- Low energy injection(11 MeV) , Problems of energy loss and emittance growth
- Energy loss will be recovered by RF acceleration.
- Lowering the energy loss and emittance growth by off-center injection.
- Analysis of longitudinal painting will be required.
- Orbit shift by acceleration for escaping method from stripping foil.

scheme

1. Multi-turn injection method by charge-exchange
2. RF capture or acceleration during beam injection
3. RF acceleration after beam injection

Issues

- Stripping Foil
 - Thickness of stripping foil
 - Estimation of energy loss
 - How to make stripping foil
 - Setting method , Changing method
- Injection Scheme
 - emittance growth
 - Effects of off-center injection
 - How to escape the stripping foil

Stripping Foil

- Carbon foil (product of arizona carbon foil company)
- Trial fabrication of stripping foil ($10\mu\text{g}/\text{cm}^2$, $20\mu\text{g}/\text{cm}^2$)
- Stripping efficiency $\sim 98\%$
- Because this thin foil is too brittle, sensitive handling is required

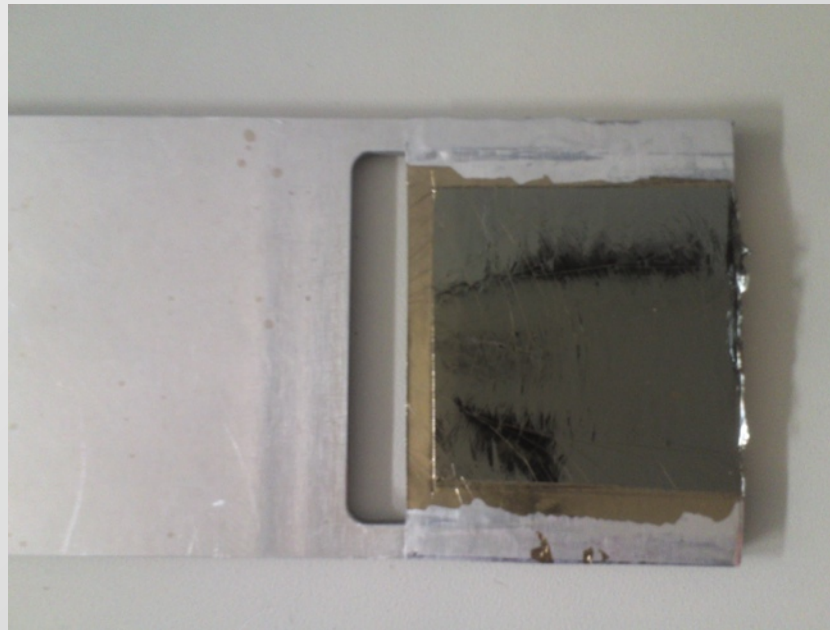

$10\mu\text{g}/\text{cm}^2$ two layer = $20\mu\text{g}/\text{cm}^2$

Outline of fabrication of the carbon foil

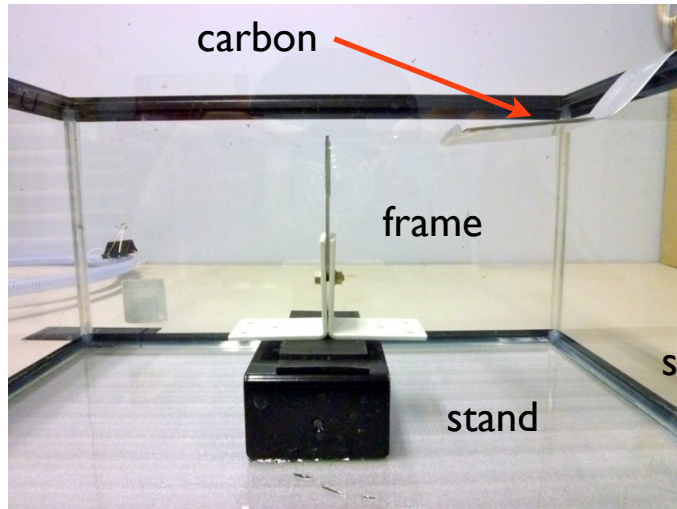

1 2

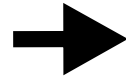

supply the water

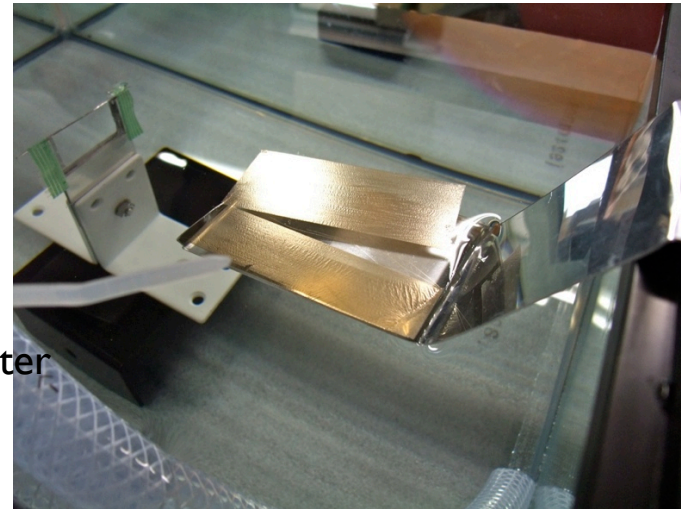

Carbon foil slide ↓ to center of frame.

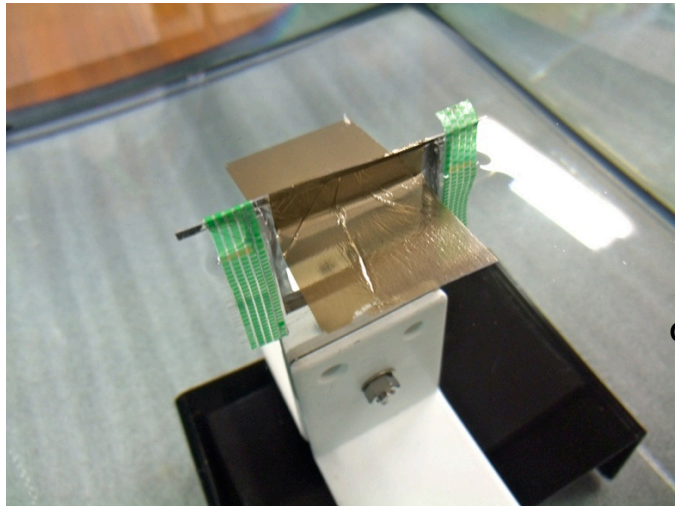

4 3

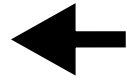

drain the water

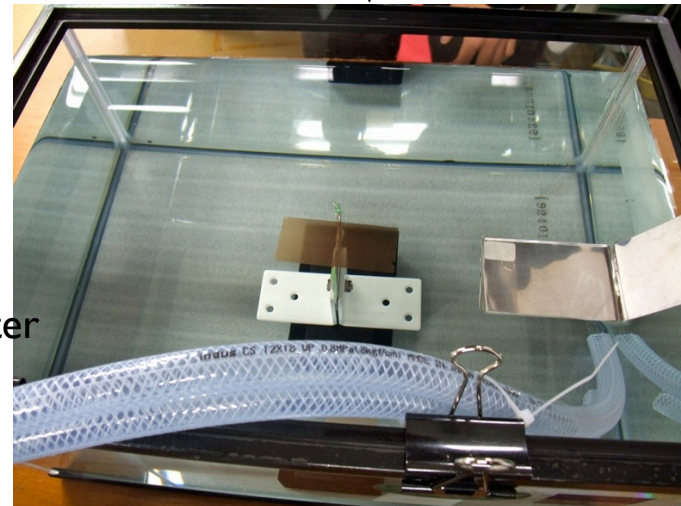

Charge-exchange efficiency

Material of charge-exchange foil is made of carbon.
Because carbon is cheap and easy to make.

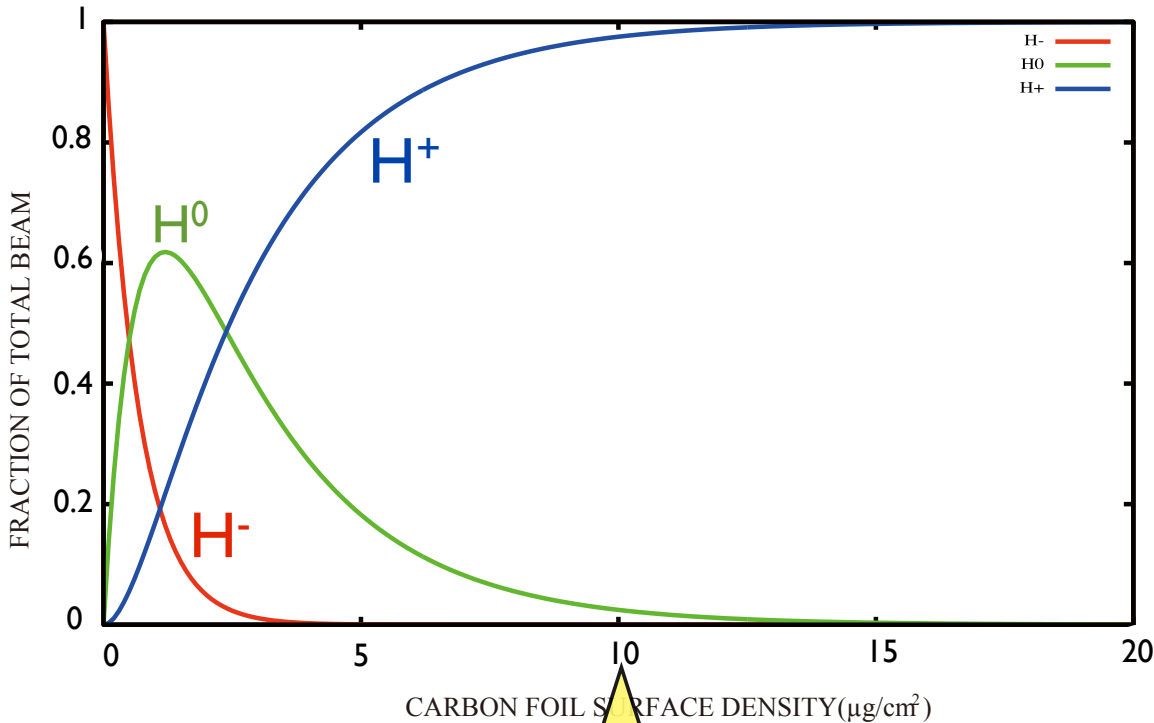

Thickness of carbon foil	charge-exchange efficiency(%)
$5\mu\text{g}/\text{cm}^2$	81.7%
$10\mu\text{g}/\text{cm}^2$	97.5%
$15\mu\text{g}/\text{cm}^2$	99.6%
$20\mu\text{g}/\text{cm}^2$	99.9%

Figure 1 charge-exchange efficiency

The thickness of carbon foil minimum is required to be more than $10\mu\text{g}/\text{cm}^2$.

Energy Loss

Energy loss by carbon foil is indicated by the Bathe equation. Energy loss depends on the foil thickness. If we choice thickness of carbon foil under $20 \mu\text{g}/\text{cm}^2$, energy loss will be recovered by RF acceleration.

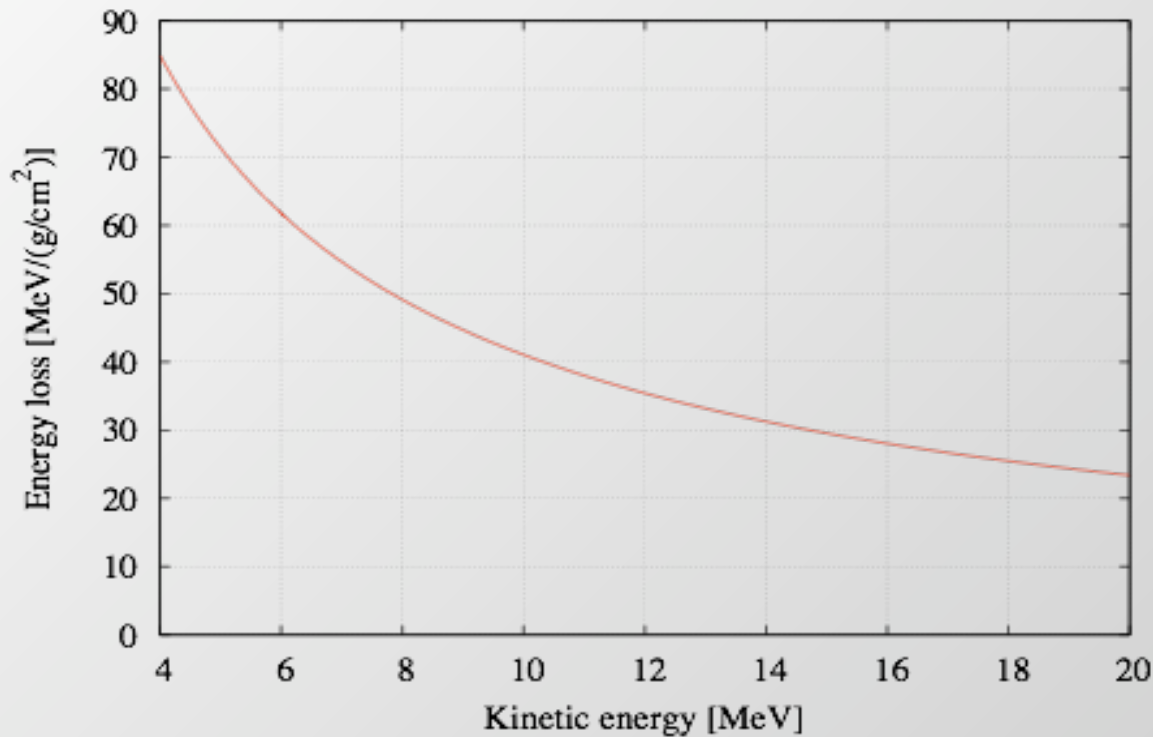

- Striping foil : Carbon
- Energy loss
20 $\mu\text{g}/\text{cm}^2$: 760eV
10 $\mu\text{g}/\text{cm}^2$: 380eV
- Gap voltage of cavity
> 2 kV

Foil change machine

View port to watch foil condition

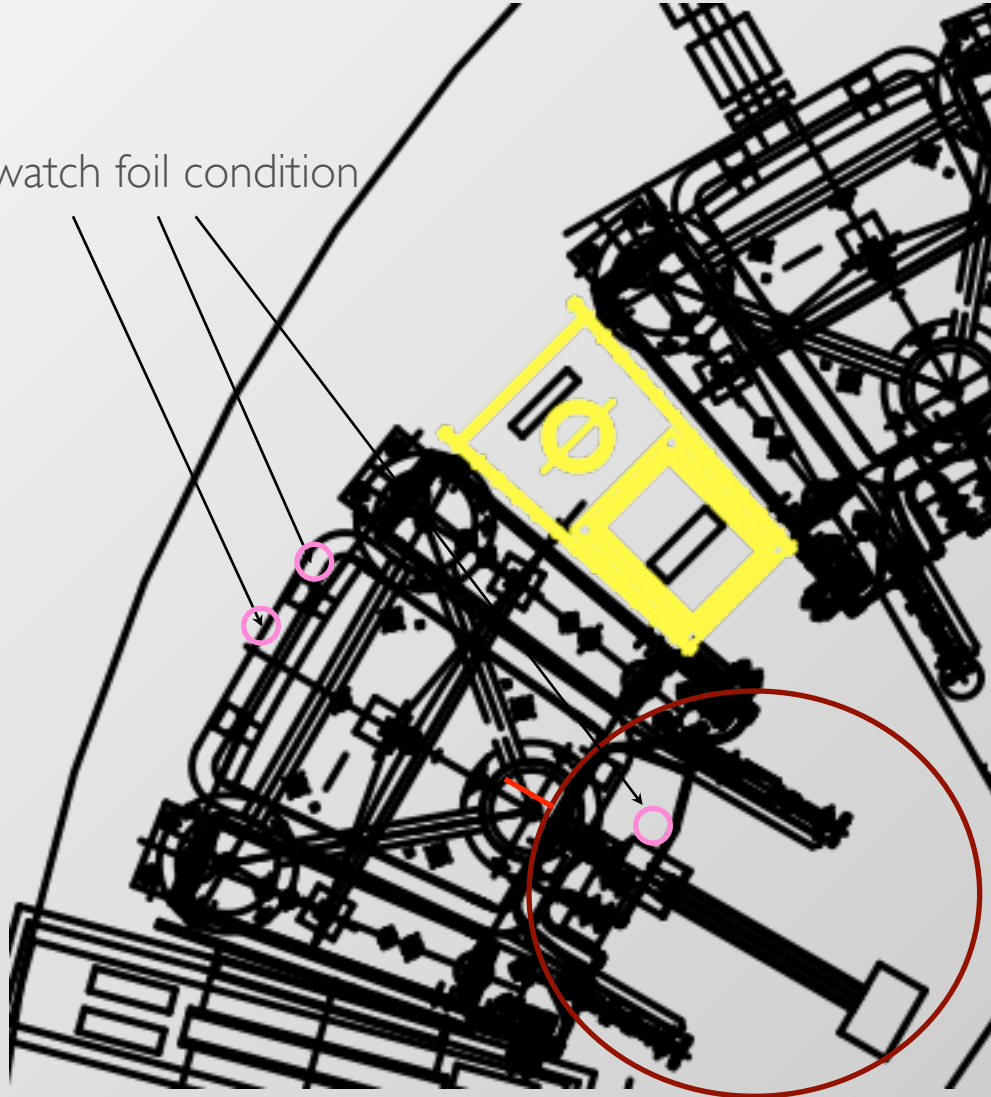

Mechanism for Foil Change

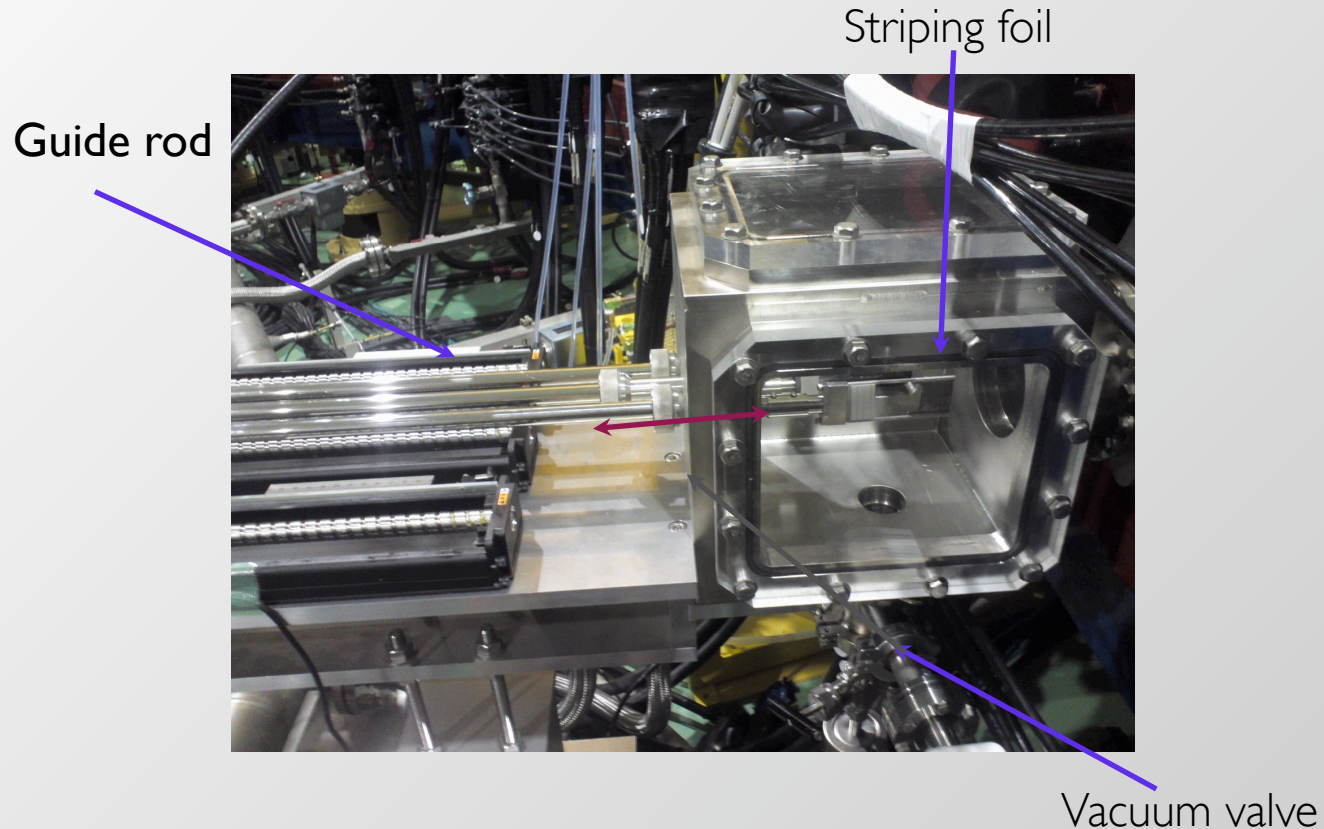

- Three foils will be exchangeable without vacuum breaking.
- The foil change box is separated from main ring chamber by valve.
- Because this thin foil is too brittle, we should evacuate slowly by rotary pump. when vacuum is under 1 pascal, vacuum valve is opened and foil is installed inside of ring.
- To control foil position, drive force with remote controller is installed.

Emittance Blow up(I)

Low energy injection(11 MeV), circulated beam hit foil many times.
Energy loss and emittance growth are become problem.

Longitudinal

$$\frac{d\langle\sigma_E^2\rangle}{ds} = -2\left.\frac{\partial(dE/ds)}{\partial E}\right|_0 \langle\sigma_E^2\rangle + \frac{d\langle\Delta E_{rms}^2\rangle}{ds}$$

Horizontal

$$\frac{d\varepsilon_x}{ds} = -\frac{1}{\beta^2 E} \frac{dE}{ds} \varepsilon_x + \frac{\beta_x E_s^2}{2\beta^3 m_p c^2 L_R E}$$

Vertical

$$\frac{d\varepsilon_y}{ds} = -\frac{1}{\beta^2 E} \frac{dE}{ds} \varepsilon_y + \frac{\beta_y E_s^2}{2\beta^3 m_p c^2 L_R E}$$

Emittance Blow up(2)

Foil thickness : $20 \mu\text{g}/\text{cm}^2$

C $20\mu\text{g}/\text{cm}^2$

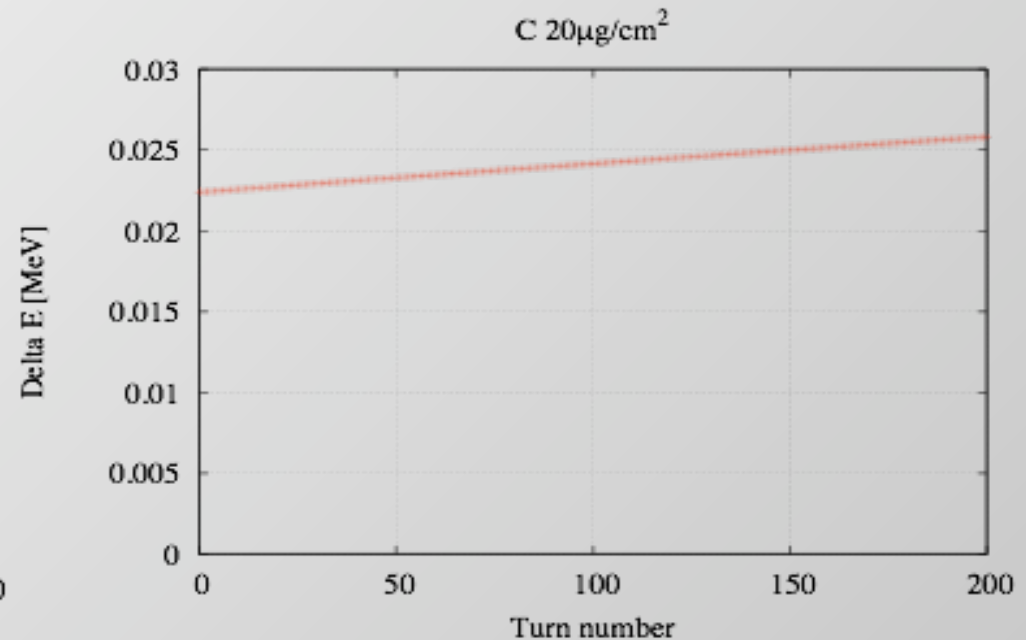
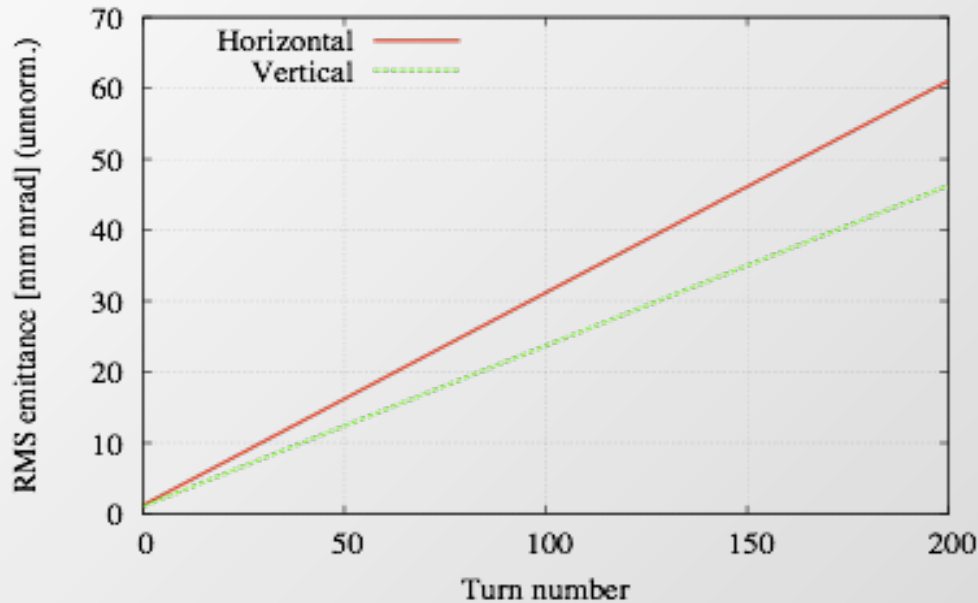

- disp. : $0.54[\text{m}]$
- hori. beta : $3.31[\text{m}]@\text{foil}$
- vert. beta : $2.50[\text{m}]@\text{foil}$

Off-center Injection

Low energy injection(11 MeV), circulated beam hit foil many times. Energy loss and emittance growth are become problem. To decrease the hitting probability, H- beam is injected off-center by about 10 mm parallel shift of injection line.

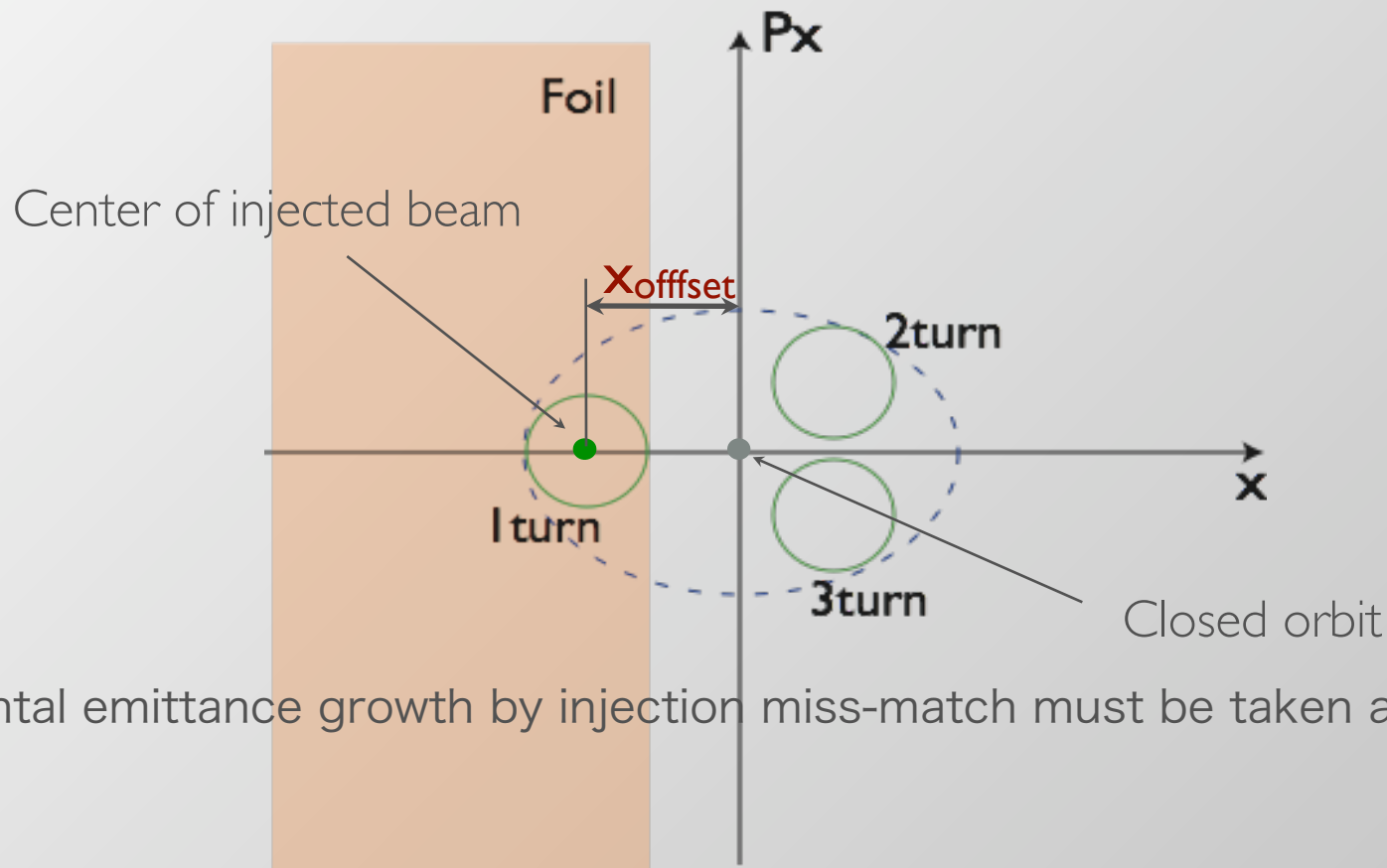

Horizontal emittance growth by injection miss-match must be taken account.

Foil escaping process after injection

As an escaping method from stripping foil, orbit shift by acceleration is available in FFAG accelerator. In this scheme, no pulse device such as bump magnet for injection is needed. But, to escape from stripping foil rapidly, rf cavity with high gap-voltage become essential.

Because of low energy charge exchange injection, energy loss and emittance growth in the stripping foil are big problems.

The mean energy loss of 11 MeV proton beam is about 340(760)eV at 10(20) $\mu\text{g}\cdot\text{cm}^{-2}$ carbon foil. The 4kV gap-voltage is enough to re-accelerate injected beam which lost energy in stripping foil.

- Carbon foil
- Energy loss at foil
- 380eV 10 $\mu\text{g}/\text{cm}^2$:
- 760eV 20 $\mu\text{g}/\text{cm}^2$:
- RF voltage : 4kV

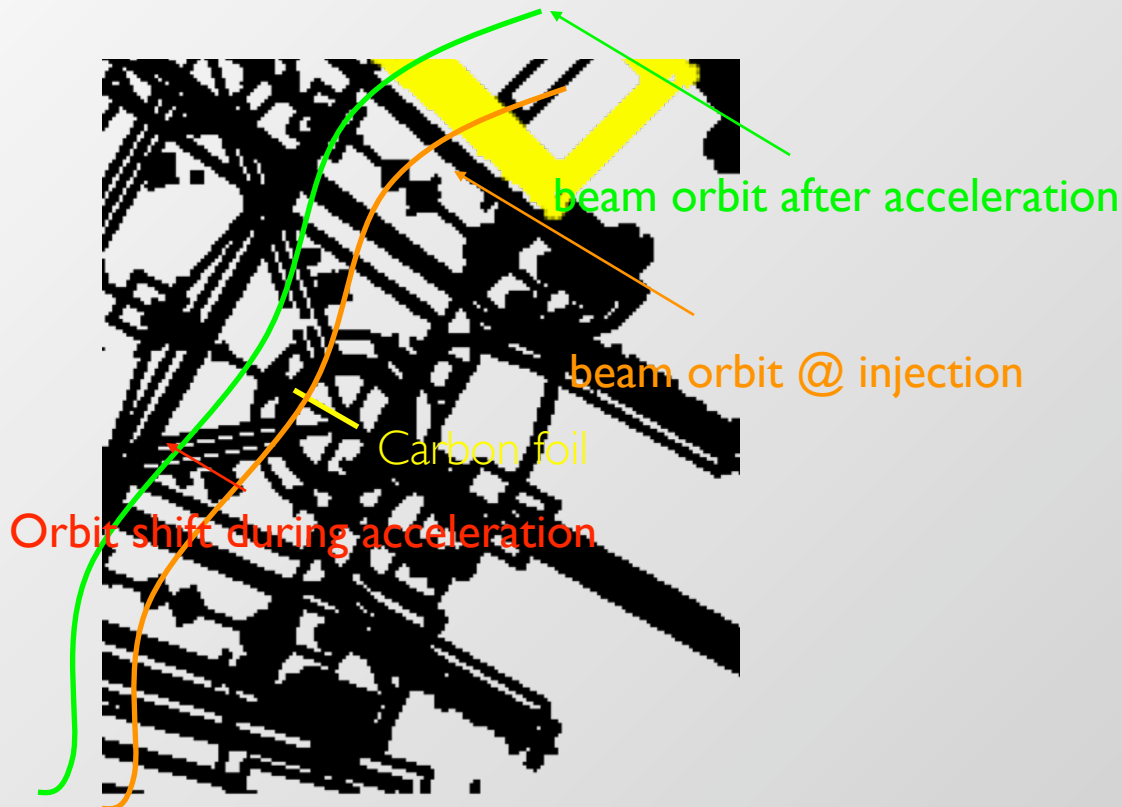

Simulation of accelerate after capture

- Linac beam : 100us(flat), (11.0+-0.03) MeV
- Foil : 20ug/cm²(E loss 760eV), 10mm width
- RF voltage : 4kV

Flow of beam injection

- Injected beam is accelerated during injection(100us)
- Acceleration phase : 20, 40deg.

Detail of this simulation will be talked by Tom. Uesugi at tomorrow presentation.

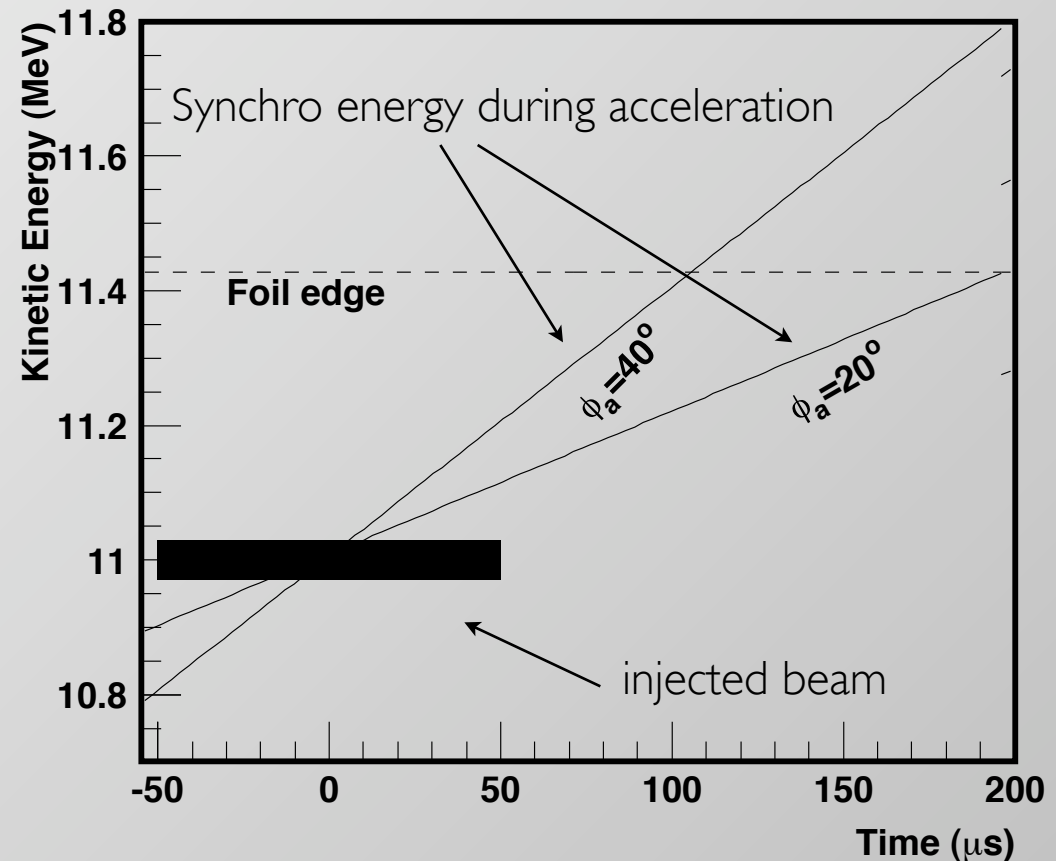

(Example) Results of simulation

Acceleration phase : 20deg.

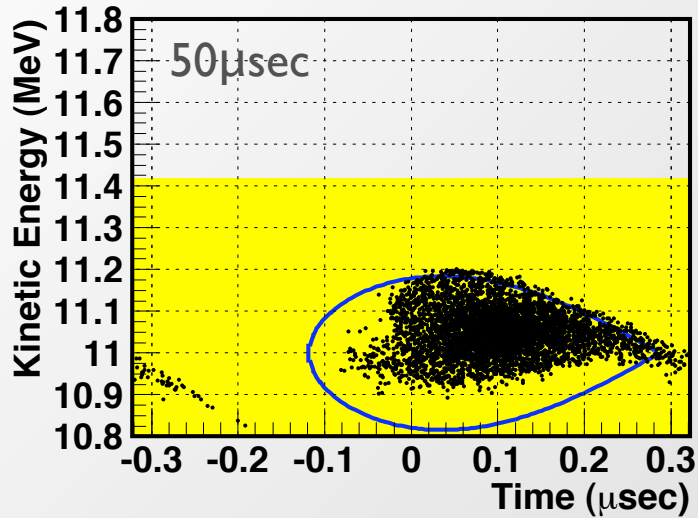

- At the start, continuous beam is injected during 100micro sec.
- In upper figure, black points are phase space distribution of injected beam after 50microsec.
- In the case of 20(40) deg, ratio of accelerated particles after 250microsec acceleration is about 35(10)%.

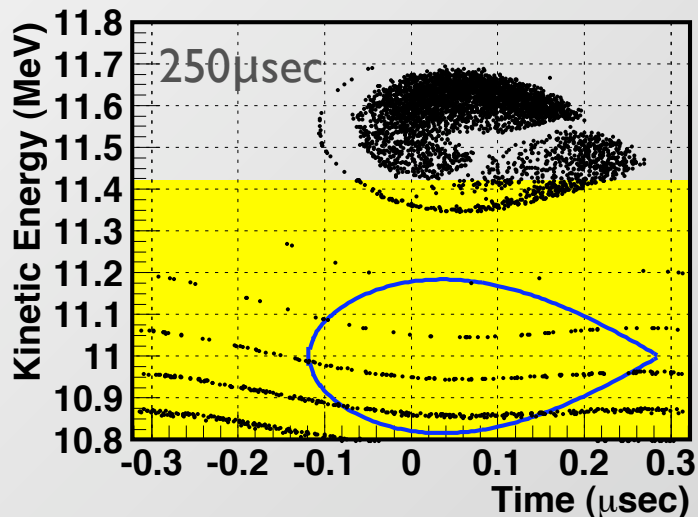

- The integrated number of foil-hits by macro-particles are counted in the same simulations. The mean hit number of particles is about 600(160) times at $\phi_s = 20(40)\text{deg}$ for $20\mu\text{g}/\text{cm}^2$ thickness

Foil heating

The governing equations for the heat transfer analysis on the carbon foil can be expressed as follows:

$$\frac{dT(t)}{dt} = (W(t) - \sigma \cdot \epsilon \cdot S \cdot (T(t)^4 - T_0^4)) / (q \cdot m)$$

$$W(t) = D \cdot I(t)$$

Boltzmann constant, $\sigma = 5.67 \times 10^{-8} [\text{W/m}^2\text{K}^4]$

Area on the foil surface: $S = (3\text{cm} \times 2\text{cm})$

Ambient temp.: $T_0 = 293 [\text{K}]$

Heat capacity : $q = 0.59 [\text{J/g}]@400[\text{K}]$

Rad. Emissivity : $\epsilon = 0.6$

Energy Loss : $D = 380[\text{eV}]@10\mu\text{g}/\text{cm}^2$

After injection, all the particles hit the stripping foil over 160 turns.

The integrated results of Equation for the initial three cycles are shown in left figure.

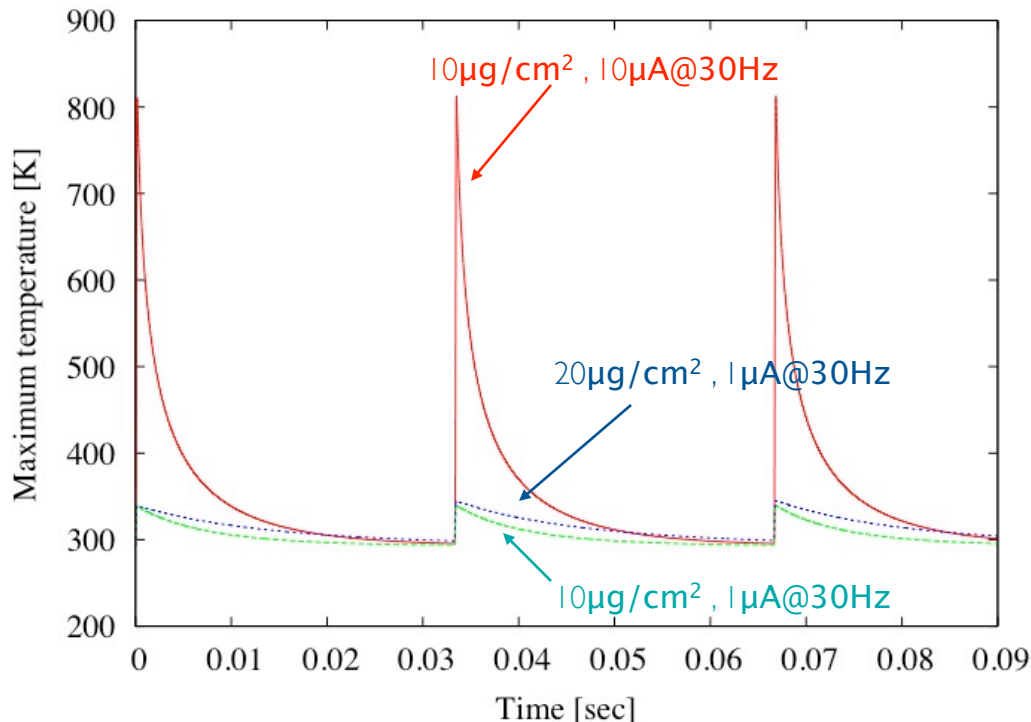

- (1) The temperature cycles on these foils become stable after the second heating cycle.
- (2) The maximum temperature on the $10\mu\text{g}/\text{cm}^2$ thickness foil would fluctuate from 300 K to 350 K for the $1\mu\text{A}$ case and from 300 K to 800 K for the $10\mu\text{A}$ case.
- (3) Maximum temperature of $10\mu\text{g}/\text{cm}^2$ thickness and $20\mu\text{g}/\text{cm}^2$ thickness are almost same.

Beam study of H- injection

2011/01 ~ 2011/02

H- injection beam commissioning

- Linac beam : $I \sim 5\text{mA}(\text{peak})$, $0.4 \sim 14\mu\text{s}(\text{flat, with chopper})$, 11.0 MeV ,
rep. rate : $1 \sim 20\text{Hz}$
- Foil : $20\mu\text{g}/\text{cm}^2$ (E loss 760eV), 30mm width
- RF voltage : $2 \sim 4\text{kV}$
- On axis injection

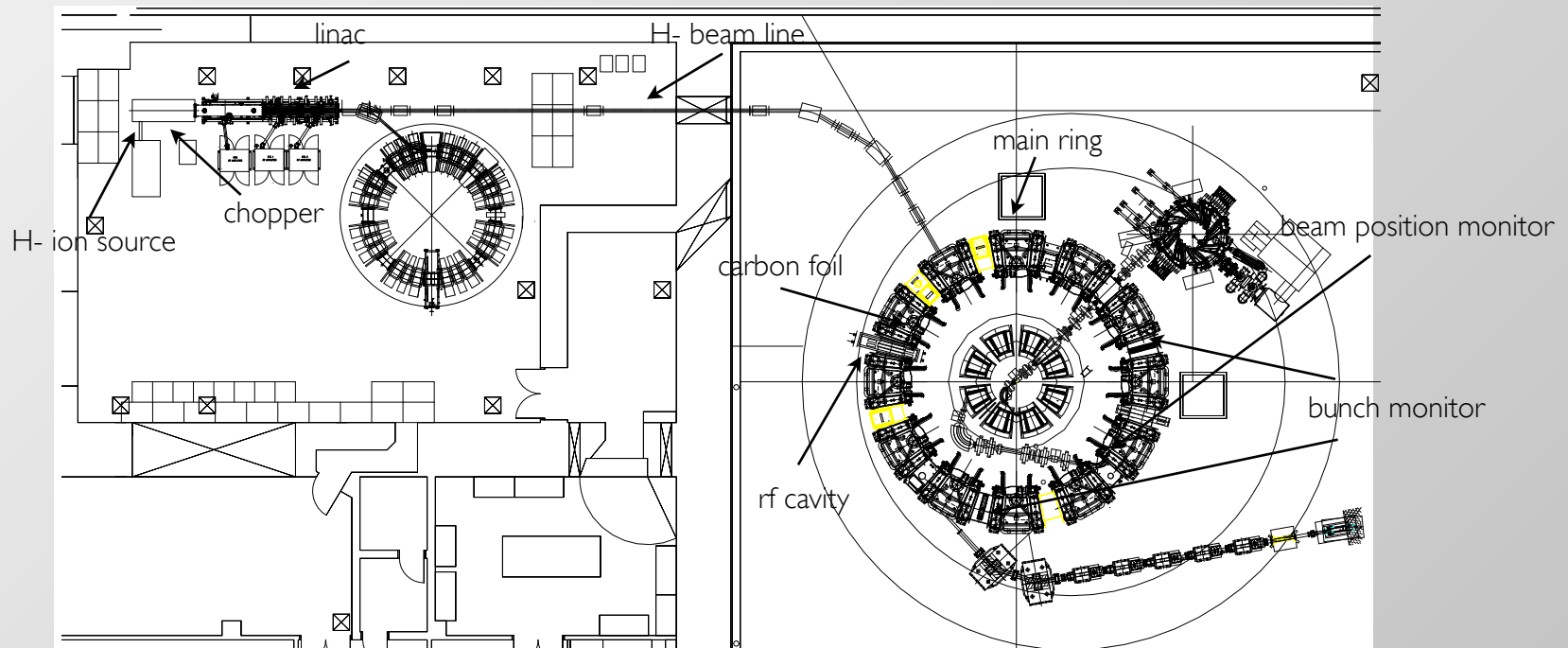

Flow of beam injection commissioning

1. In order to determine that the injected beam is merged to the circulating orbit in the FFAG main ring, we studied single turn injection by chopped injection beam without rf acceleration.
2. Multi-turn injection study with constant rf frequency.(rf capture) The rf amplitude is around 2 kV, rf frequency is 1.557MHz.
3. Study of foil escaping process. Injected beam was accelerated after charge exchange injection. The rf amplitude is over 4 kV, acceleration phase is 30 deg.

Single turn injection study

In order to determine that the injected beam is merged to the circulating orbit in FFAG main ring, single turn injection by chopped injection beam without rf acceleration was studied.

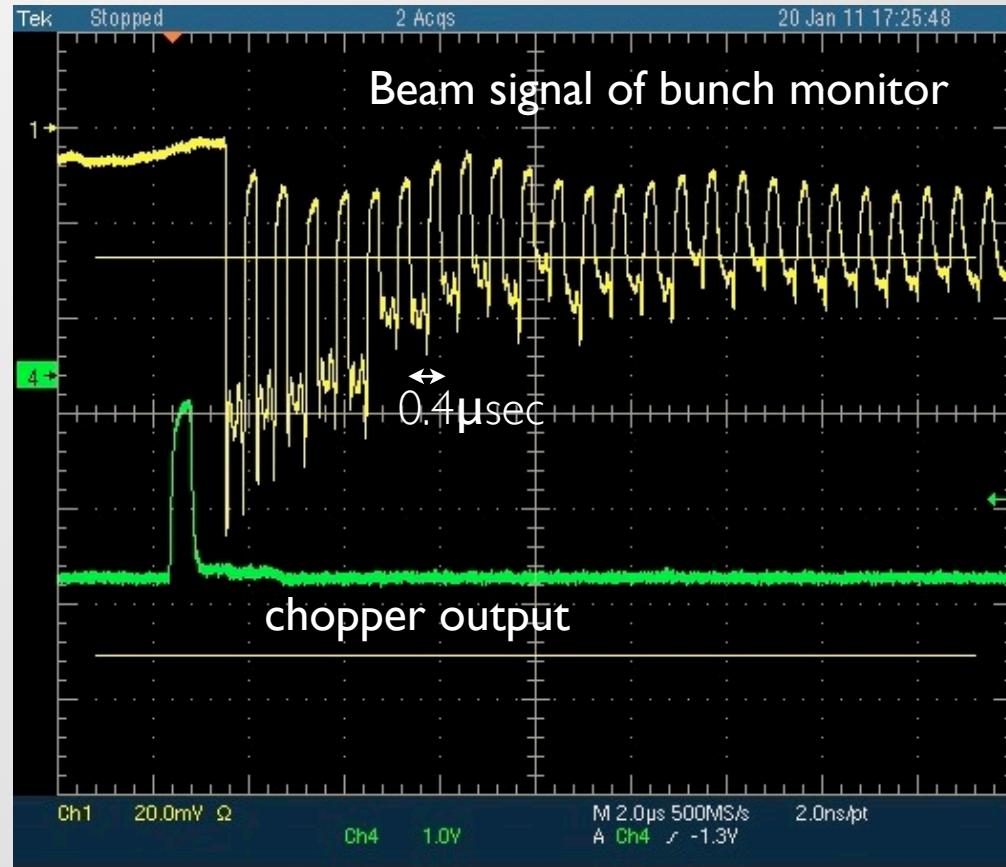

- Injection beam is chopped shorter than revolution period. Injected beam circulated over 100 turns by steering magnet and foil position optimization.
- However, after a few turns, the injected beam is gradually lost by the effect of injection mismatch.

Multi-turn injection study

Frequency of rf cavity is constant, no acceleration. The rf amplitude is over 2 kV, rf frequency is 1.557MHz.

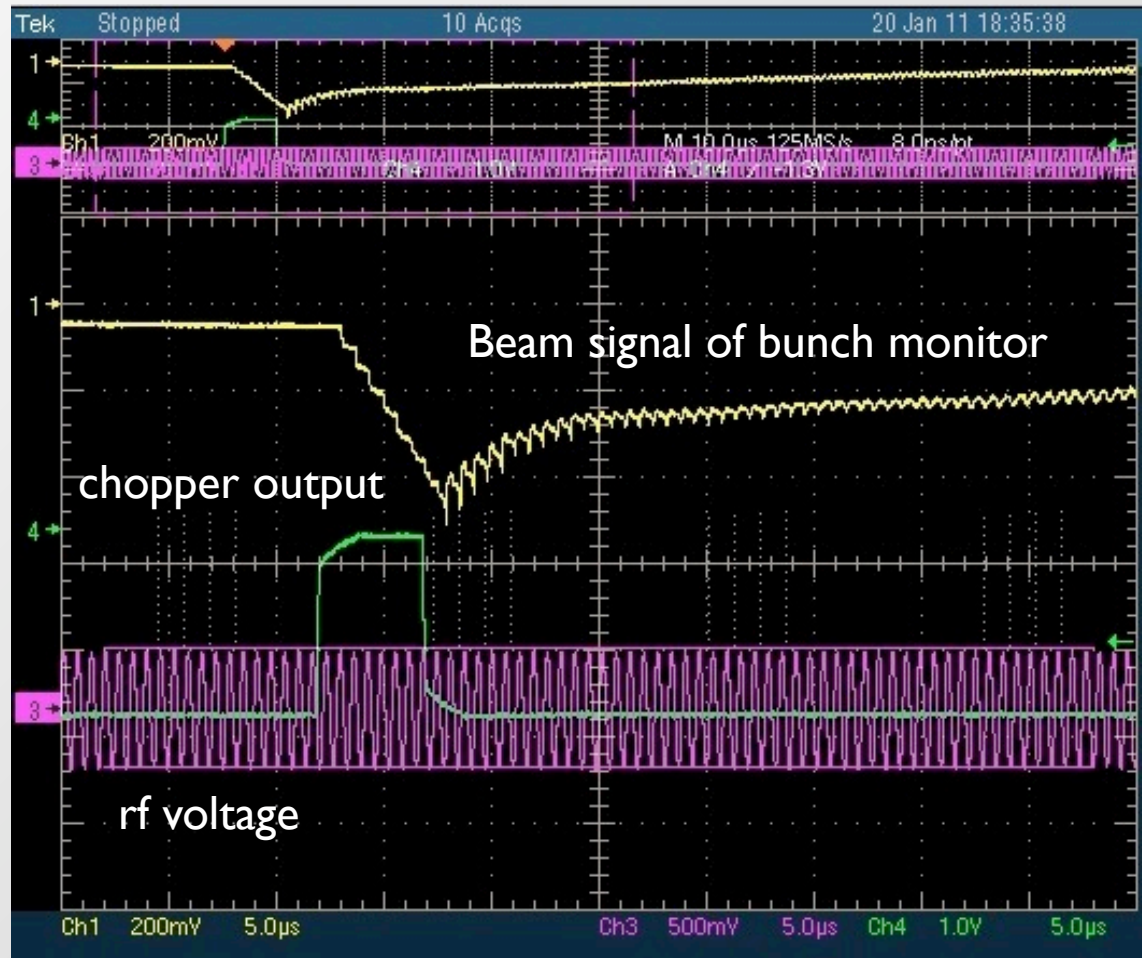

- Pulse length of injection beam is 5 μ sec, injection turn number is about 8 turns.
- From this figure, circulating beam current was increase during multi-turn injection.

Acceleration study of injected beam

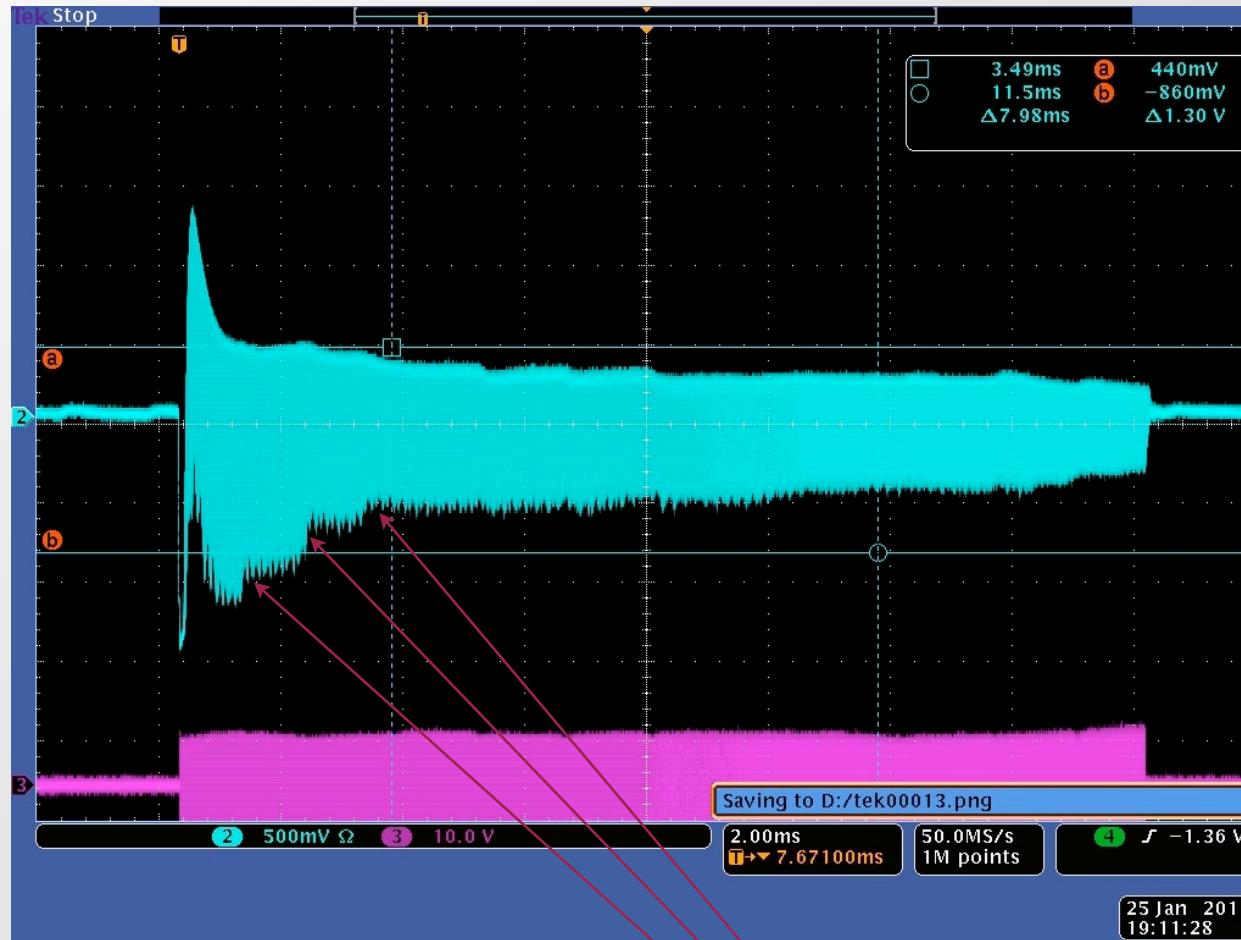

- Injected beam was accelerated from 11 MeV to 100 MeV in FFAG main ring, Synchronous phase is 30 degree.
- The foil escaping of injected beam by was performed beam by rf acceleration.
- H- injection was successfully carried out.
- But injection efficiency is not good. And we can see beam loss by resonance in low energy region.

Summary of beam commissioning 2011/01 ~ 2011/02

2010/Nov : construction of H- beam line

2010/Dec : study of H- beam line

2011/Jan ~ Feb : H- beam injection and acceleration study

- H- injection orbit and circulating orbits was established in FFAG main ring.
- From experimental result, orbit shift to escape the stripping foil was demonstrated by rf acceleration.
- H- injection was successfully carried out.
- Injected beam was accelerated from 11 MeV to 100 MeV in the main ring.
- The fatal foil damage by beam hitting was not observed

Issues

1. Beam loss of H- beam line.
2. H- beam injection efficiency
3. Beam loss during acceleration by some resonance

To-do lists (2011/Apr)

- Emittance measurement of linac beam
- Re-alignment of beam line magnets
- Tune-up of beam line
- Buildup of rf power to rapid beam escaping from injection foil
- To reduce beam loss by resonance

Result of emittance measurement (just outside of linac)

we assumed

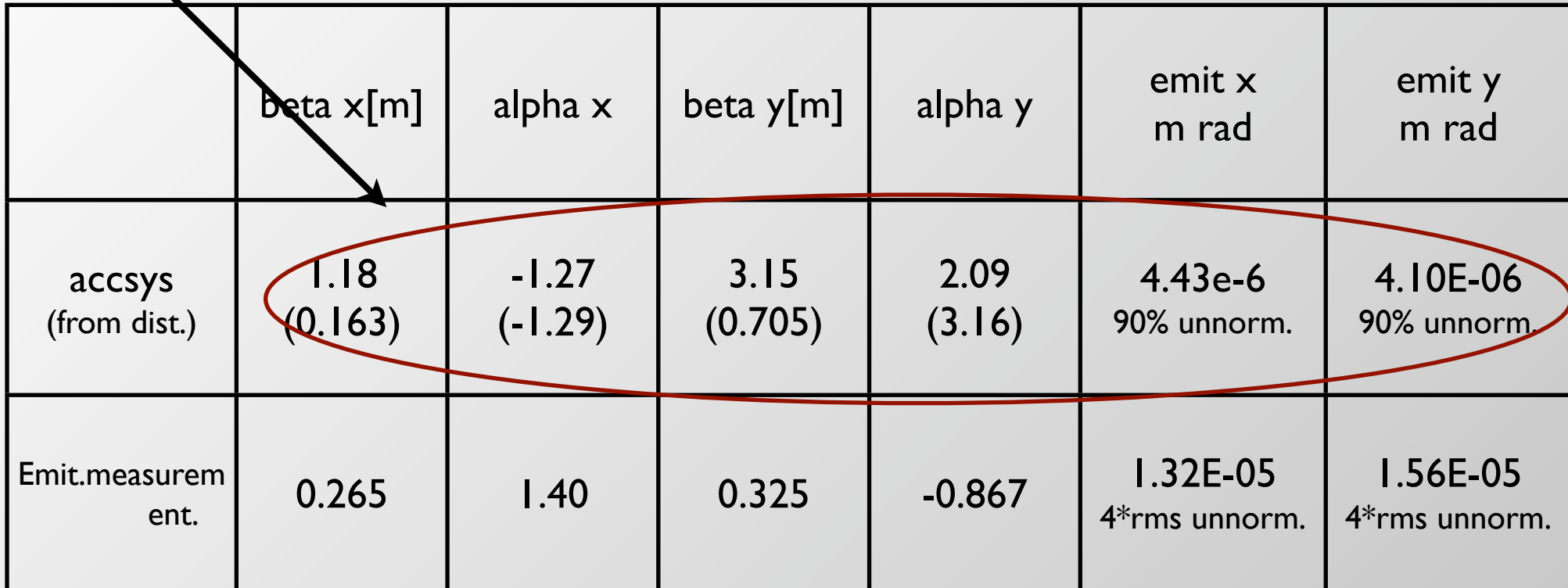

	beta x[m]	alpha x	beta y[m]	alpha y	emit x m rad	emit y m rad
accsys (from dist.)	1.18 (0.163)	-1.27 (-1.29)	3.15 (0.705)	2.09 (3.16)	4.43e-6 90% unnorm.	4.10E-06 90% unnorm.
Emit.measur- ent.	0.265	1.40	0.325	-0.867	1.32E-05 4*rms unnorm.	1.56E-05 4*rms unnorm.

- Twiss parameters from accsys in parentheses are calculated from particle distribution of tracking simulation results.
- Beam measurement results -> 40 cm inverse calculation from measurement point.

New H- beam-line(magnets)

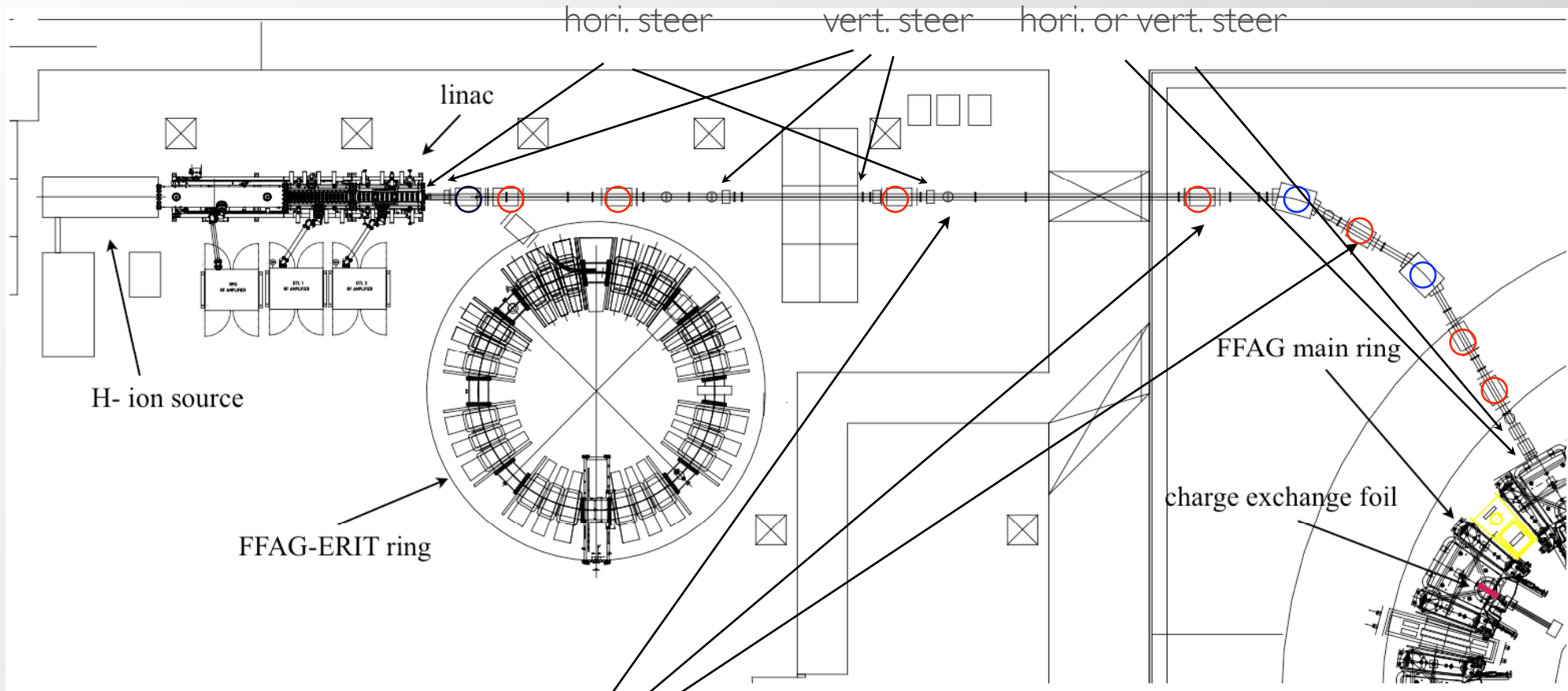

- The alignment accuracy of these quad. magnets was not good. (~ 3mm miss-alignment)
- Beam line was slightly modified. To improve final twiss para. and dispersion matching, we added one QM after linac.

New Beam optics

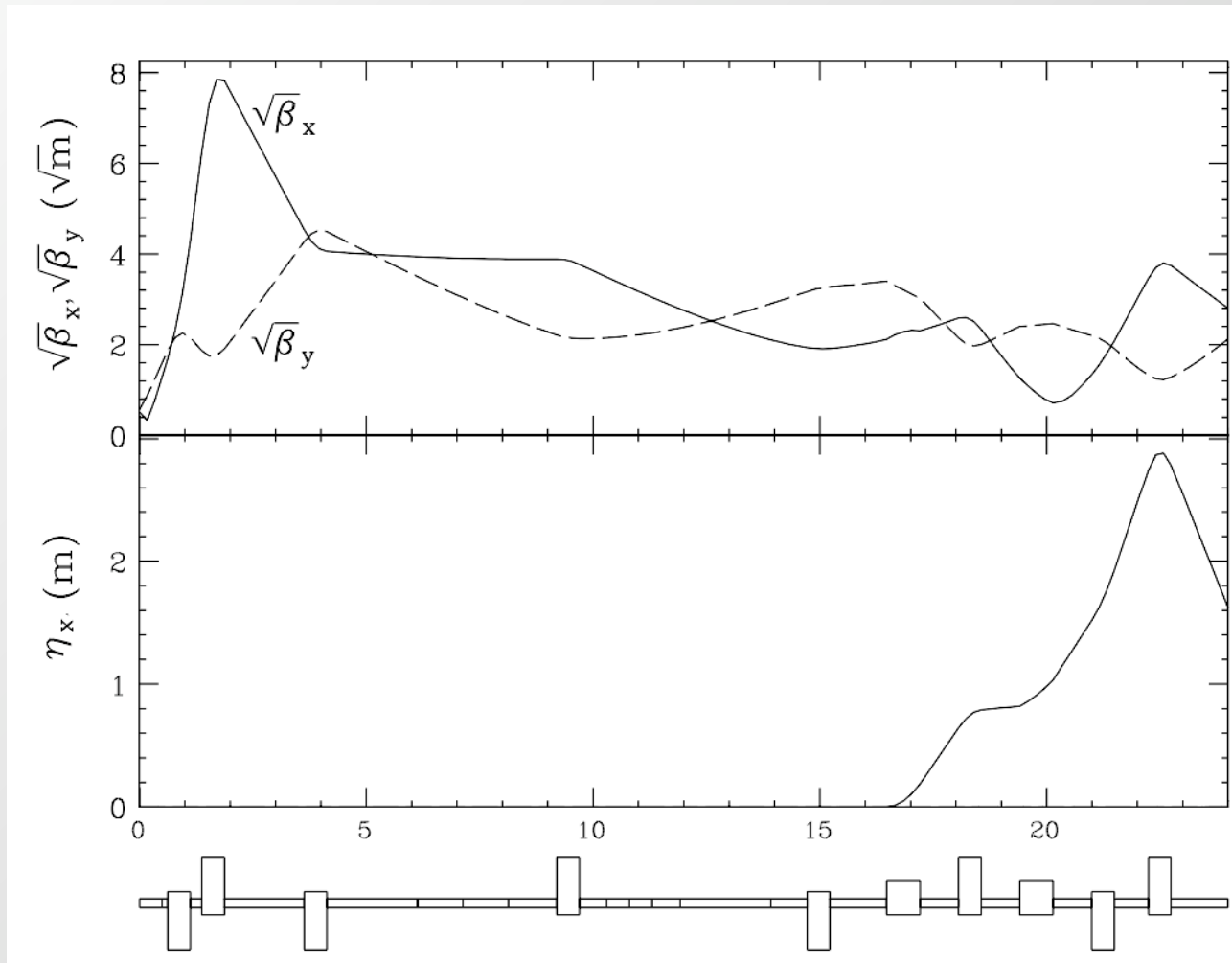

linac ST QD QF ~

Initial twiss para. -> Beam measurement

To-do lists (Now)

- ✓ Emittance measurement of extract beam of linac
- ✓ Re-alignment of beam line magnets.
- ✓ Tune-up of beam line

- Buildup of rf power to rapid beam escaping from foil
 - New additional rf cavity is studied and will be installed to the main ring in near future.
- To reduce beam loss by resonance
 - Take away resonance source (injection septum for booster injection?) in the main ring. And optimization.

injection septum for booster injection

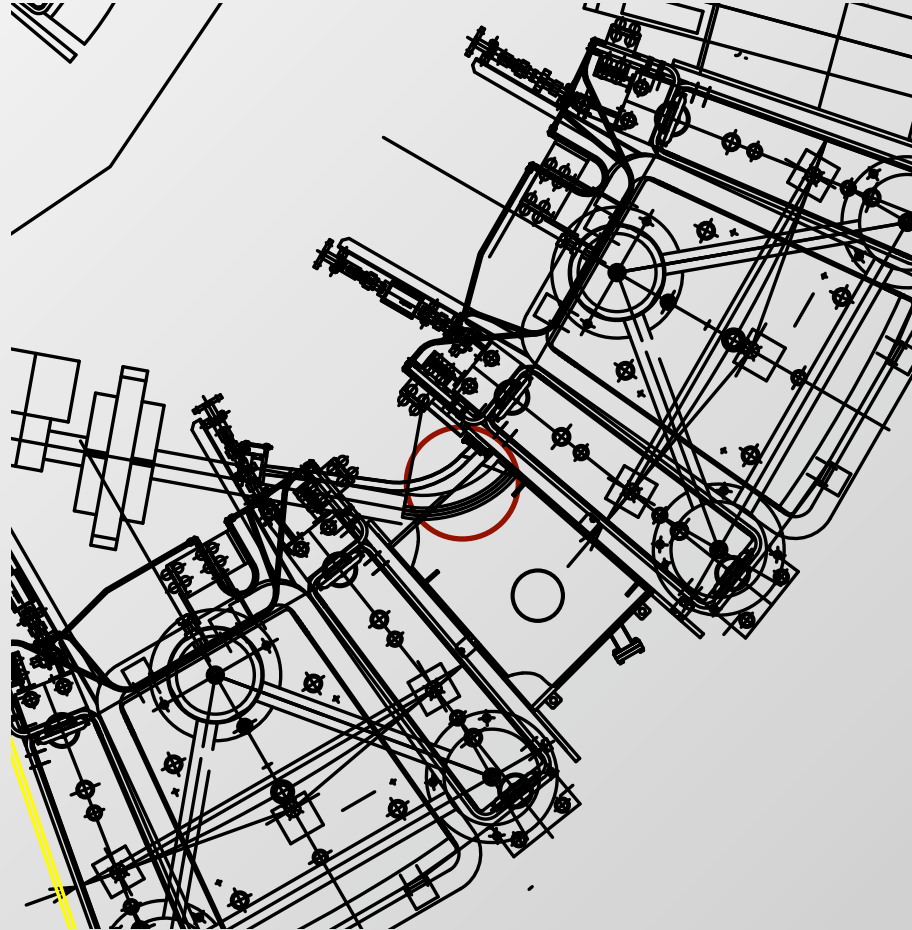

Injection septum is large iron body. This magnet is positioned near the main magnet and the injected beam. We think that this magnet becomes a strong resonance source.

Summary

- New Injectors
 - H-beam from Linac will be injected by charge-exchange injection method.
- Injection beam line
 - Beam merging of H- and H+ beam is performed by main magnets of FFAG.
 - Stripping foil position has decided to be at the center of F-magnet by beam tracking simulation.
 - Beam transport line has designed by SAD.
- Striping Foil
 - Carbon foil with its thickness 10~20 $\mu\text{g}/\text{cm}^2$
 - 10 $\mu\text{g}/\text{cm}^2$ foil is very fragile and hard to handling. 20 $\mu\text{g}/\text{cm}^2$ is rather easy for handling.
 - We have developed the system that at least three carbon foils are changeable without vacuum breaking.

- Injection Scheme of H-injection
 - Escaping from stripping foil by orbit shift with RF acceleration.
 - Emittance blow up by multiple scattering with suppressed to the half value by lowering the hitting probability using off-center injection.
 - Emittance value after 160 turn is less than 20 mm•mrad.
 - Orbit shift to escape the stripping foil will be performed by RF acceleration.
 - The upgrade of RF Voltage will be required for faster orbit shift.
- Construction of new beam line is completed.
- Beam commissioning of H- injection
 - H- injection orbit and circulating orbits was established in FFAG main ring.
 - From experimental result, orbit shift to escape the stripping foil was demonstrated by rf acceleration.
 - H- injection was successfully carried out.
 - Injected beam was accelerated from 11 MeV to 100 MeV in FFAG main ring.
 - The fatal foil damage by beam hitting was not observed
- Now, improvement of H- beam injection and optimization is done.